



RK ROSE+KRIEGER

A Phoenix Mecano Company

Connecting Technology

Flexible clamping
and release of tubes



Introduction

How to use this catalogue

If you are new to connecting technology

Please use our selection guide from page 9 onwardp.
We will guide you to the right product for your particular application.

If you know all about connecting technology

You know exactly what you require and can go straight to the right product category, where you will find a product overview on the first pagep.

Specific search

...if you are looking for a specific product, we suggest you start in our index on the last pages of this catalogue.

From page 4 Introduction
 About Us
 Our products
 Service
 Level of service

From page 9 Connecting Technology Selection guide
 Flexible Clamping
 (What is Connecting Technology?)
 Four steps to your recommended product
 (How do I find the right product?)

From page 24 Light Clamps
 Plastic tube connectors

 Light load range

From page 58 Solid Clamps
 Aluminium tube connectors

 Medium to heavy load range

From page 206 Robust Clamps
 Stainless steel tube connectors

 Shock-proof load range

From page 220 EMS

 stainless steel mounting system

From page 238 Accessories

From page 246 ITAS

 Industrial stairs and working platforms

From page 266 RK Monitor Mounting

From page 313 Appendix
 Sketches / Notes
 Index

Introduction

About Us

As a subsidiary of the global Phoenix Mecano AG, we offer an unrivalled range of products in the fields of linear, profile, connecting and module technology. With decades of experience and expertise in a huge range of industrial applications, you need look no further for a highly competent partner. From the first point of contact through to delivery, we focus entirely on your requirements. Individual advice and short delivery periods are two central priorities in our customer-focused corporate philosophy. Our aim is your success, and we look forward to being your strategic partner.



Head Office: Germany, Minden/Westph.

- Company sales representatives
- Distributors and system partners

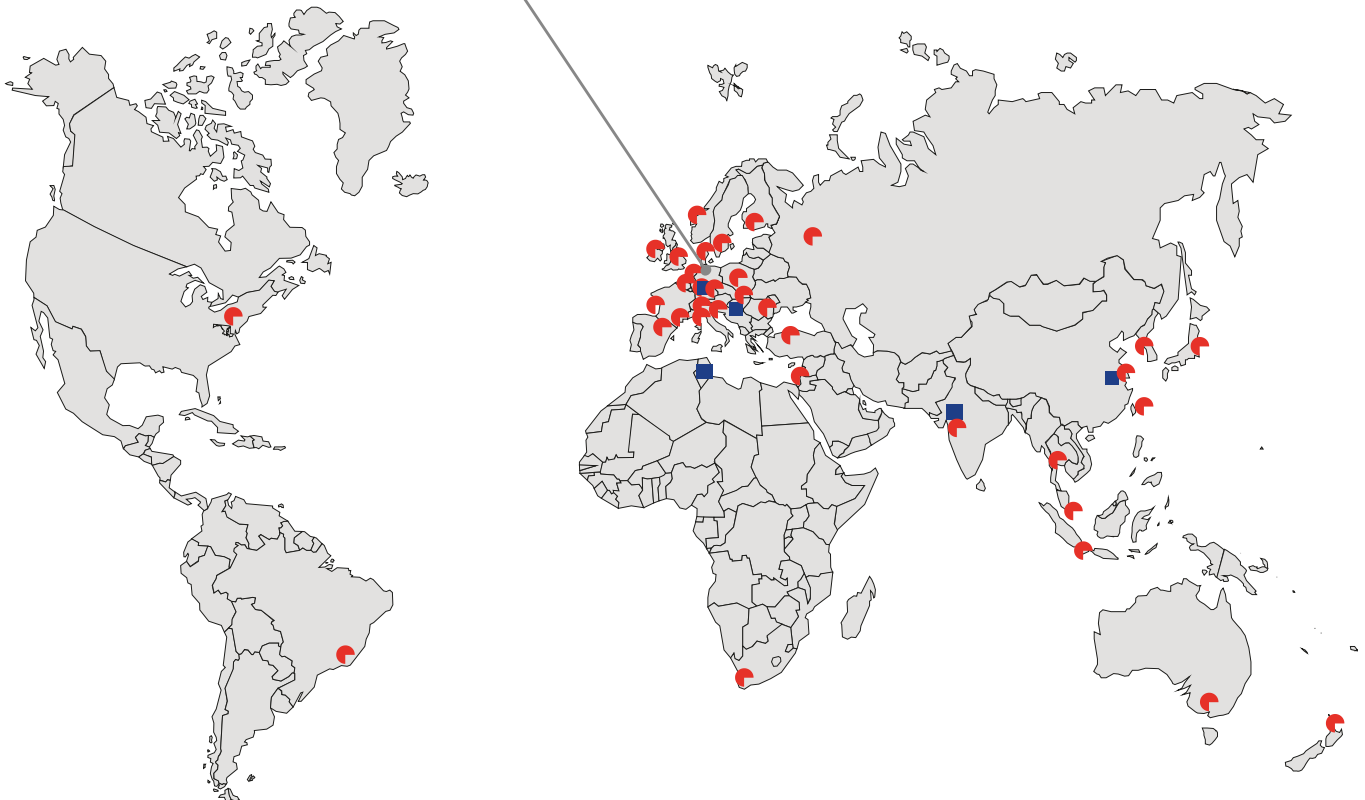

Available around the globe.

- Profit Centre within Phoenix Mecano
- Sales and system partners

■ = Production facilities

● = Distribution companies



Our product range

LINEAR TECHNOLOGY

- Linear actuators
- Manual guide units
- Electric cylinders
- Lifting columns
- We can move loads for you of up to 3 t and up to 12 m dynamically, reliably and with great precision



CONNECTING TECHNOLOGY

- Fittings for the secure clamp connection of round and square profiles
- Elements made of aluminium, stainless steel and plastic
- Sizes from 8 mm to 80 mm

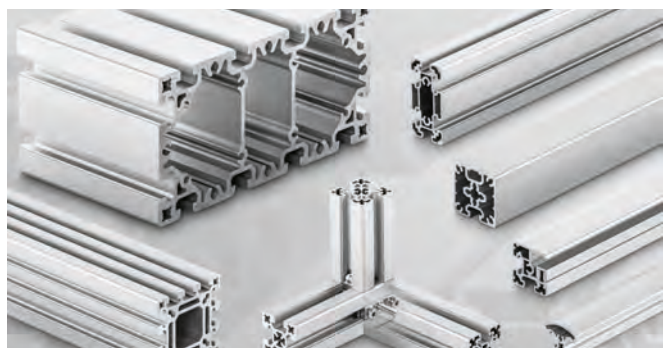

PROFILE TECHNOLOGY

- The proven and tested BLOCAN® aluminium assembly system, with profiles offering cross-sections from 20 mm to 320 mm, for a broad spectrum of applications
- Connection techniques with an unsurpassed combination of flexibility and reliability

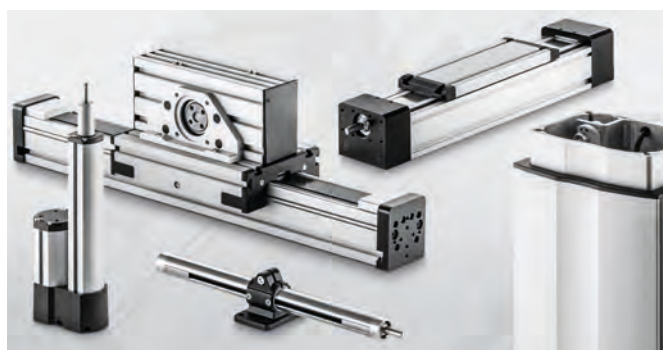

MODULE TECHNOLOGY

- We develop, manufacture and assemble
- Machine frames
- Workstations
- Machine guards
- Multi-dimensional linear actuator modules
- Complete drive solutions



Our Service

What we can do for you

We help you make the right choice:

CAD component library

To help you design your products, we give you free access to the component data stored in our Rose+Krieger component library (drawings, technical descriptions). This library lets you choose between around 60 different file formats (2D/3D). The link to our component server can be found on our web site at: www.rk-rose-krieger.com/deutsch/service/cad-daten.html



In-house RK product consultancy

The RK infovan - our showroom on your doorstep. With more than 20 presentation boards containing exhibits and functional samples and a range of applications from the world of drive and linear technology, our infovan provides a complete cross-section of the RK products currently available. Our Key Account managers and sales consultants are happy to visit you on site and help you draw up concrete proposals for practical solutionp.



RK website: www.rk-rose-krieger.com

At our website you will find a wealth of information on our company and our productp. You will also find the details of company contacts in your area and the latest catalogues (PDF format) available to download.

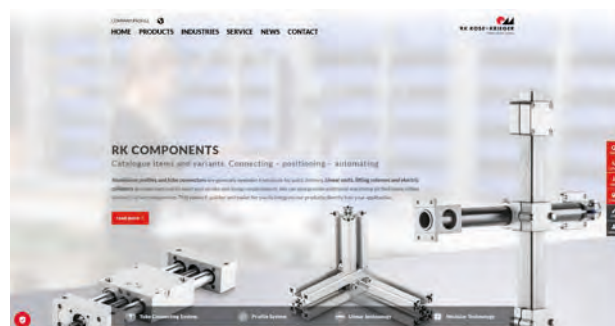

Do you need to focus your resources on other tasks and are you looking for an expert partner you can rely on? Working in close collaboration with you, our specialists will develop solutions tailor-made to meet your needp. If you wish, we can also assemble and commission the units on site.

Just make a sketch of your requirements

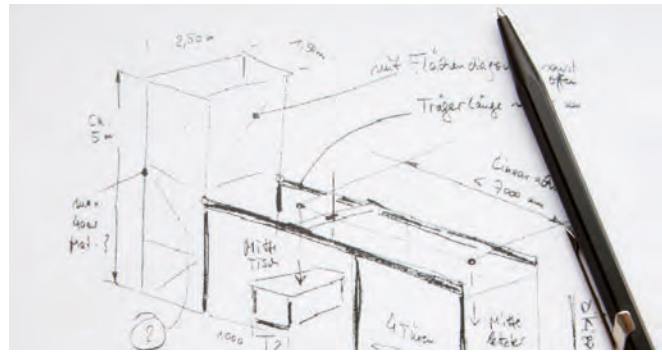

Our product specialists will develop a solution for you



We can deliver your turnkey solution or assemble and commission it for you on site



Level of service

100%

You decide...

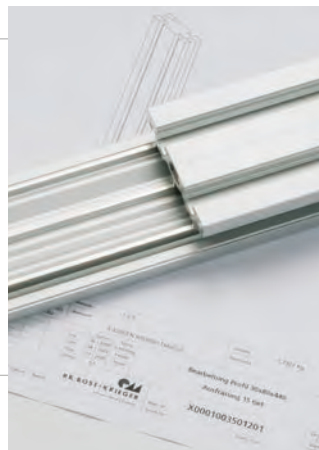

Different models, modified standards

Our expertise at your fingertip. Our expert consultants can recommend the optimum products modified to your requirements.



Customised developments

Are you looking for something completely new? Then we'll team up with you to develop it.



Modules and systems

You require your skills and time for other tasks and are looking for a partner you can rely on.

Catalogue items

If you know what you want and take the time to browse our catalogue, you are sure to find what you're looking for in our standard range.

0%

...what level of service you require

We offer

- A broad range of compatible products
- 40 years of experience in numerous industries
- Expert advice for all your requirements
- Quality – because we deliver what we promise



What is connecting technology	Page 10
How to find the right product	Page 11
The RK connecting circle.....	Page 12
Light Clamps	Page 14
Solid Clamps	Page 16
Robust Clamps.....	Page 18
EMS	Page ??
Accessories	Page 19
ITAS	Page 20
RK Monitor Mounting	Page 22

Selection guide

Flexible Clamping

What is Connecting Technology

Connecting precision round and square tube with reliability and stability whilst also making removing easy, appears to be a difficult task. The RK connecting technology, which has been proven over years of use, meets this requirement in a simple and perfect fashion.

Our versatile connection elements offer you the chance to implement creative and flexible solutions, because you can rely on our product. We are sure to have the right part for you, and if not we will develop one especially.

Why drilling, riveting, welding...



...when it's quicker with our reliable clamping system.

Four steps to your recommended product

Step 1:



The application always takes centre stage

- Light load range
- Medium to heavy load range
- Shock-proof load range

Step 2:



What features should the product have?

- Right angle connection
- Axially parallel connection
- Hinge connection

Step 3:



Which product design do you want?

- Single-piece elements:
for faster and more economic assembly
- Multi-piece elements:
for add-on assembly and upgrading

Step 4:

Which performance category do you require?

- Round tube
- Square tube
- Ø Diameter
- □ Square

...follow our system and the terms are self explanatory.

The RK Connecting Circle



Light load range

- Easy
- Good value
- Variable

Light Clamps
continue on page 14

Your
application
takes
centre stage



Solid Clamps
continue on page 16



Medium to heavy load range

- Reliable
- Solid
- Price/Performance optimised
- Great variety

Robust Clamps
continue on page 18



Shock-proof load range

- Extremely strong
- Vibration proof
- Impact and shock load
- Corrosion resistant







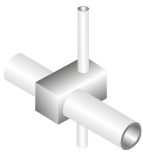
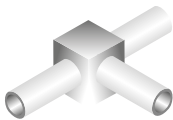
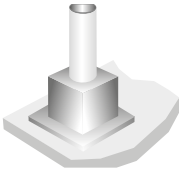
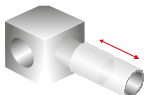

Selection guide

Light Clamps

Light load range

Plastic:

- Corrosion resistant
- Low weight
- Usable in food packaging
- Variable using reducing bushes

					Right angle connection					
										
					Cross clamps	Angle clamps	Base clamps	Insert clamps		
Single-piece elements										
		Ø 12 - 30 □ 10, 20	Ø 12 - 30 □ 10, 20	Ø 12 - 30 □ 10, 20						
Multi-piece elements										
		Ø 20 - 30 □ 20 - 30	Ø 20 - 30 □ 20 - 30	Ø 20 - 30 □ 20 - 30						

Ø = Diameter round tube
□ = Dimension square tube

Light Clamps
Plastic

Connecting types

Axially parallel connection

Hinge connection

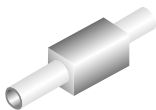

Sleeve clamps

Ø 12 - 30
□ 10, 20

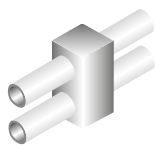

Parallel clamps

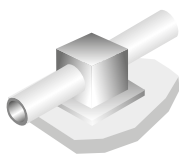

Flange clamps

Ø 12 - 30
□ 10, 20



Ø 20 - 30
□ 20 - 30

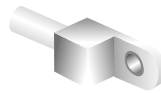

Strap clamps

Ø 12 - 30
□ 10, 20

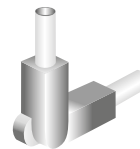

Hinge clamps

Ø 12 - 30
□ 10, 20

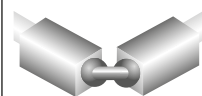

Ball joint

Ø 18

Selection guide

Solid Clamps

Medium to heavy load range

Industrial design











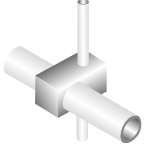
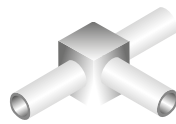
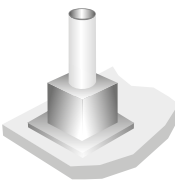
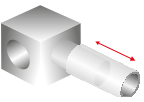





- Cast aluminium
- Great variety
- Single-piece elements

quad® elements

- Extruded aluminium
- Maximum torque loads
- High-quality anodized surface
- Single- and Multi-piece elements

Blockform

- Cast aluminium
- Higher torque loads
- Plane surface
- Multi-piece elements

		Right angle connection			
					
		Cross clamps	Angle clamps	Base clamps	Insert clamps
Single-piece elements 	Industrial-Design	 Ø 12 - 80	 Ø 12 - 80	 Ø 12 - 80	 Ø 12 - 80
	quad® elements	 Ø 30 - 50	 Ø 30 - 50	 Ø 30 - 50	
Multi-piece elements 	quad® elements	 Ø 20 - 30 □ 20 - 30	 Ø 20 - 30 □ 20 - 30	 Ø 20 - 30 □ 20 - 30	
	Block form		 Ø 8 - 80 □ 10 - 80	 Ø 8 - 80 □ 10 - 80	 Ø 42 - 50 □ 50

Ø = Diameter round tube
□ = Dimension square tube

**Solid Clamps
Aluminium**

Connecting types

Axially parallel connection

Hinge connection

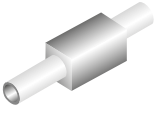
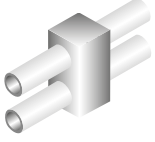
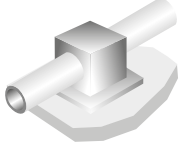
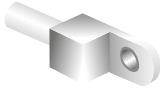
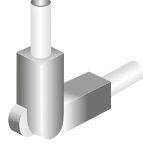
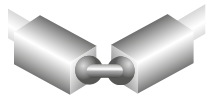
Axially parallel connection			Hinge connection		
Sleeve clamps	Parallel clamps	Flange clamps	Strap clamps	Hinge clamps	Ball joints
					
Ø 20 - 60	Ø 12 - 60	Ø 12 - 80	Ø 12 - 60	Ø 12 - 60	Ø 18 + Ø 30
Ø 30 - 50					
Ø 30 - 60 □ 30 - 60		Ø 30 - 60 □ 30 - 60			
		Ø 8 - 80 □ 10 - 80	Ø 30 - 60 □ 30 - 60	Ø 40-50 □ 40-50	

Selection guide

Robust Clamps

Shock-proof load range

Stainless steel

- Extremely strong for dynamic loads
- High temperature resistance
- Corrosion resistant
- Surface: electropolished

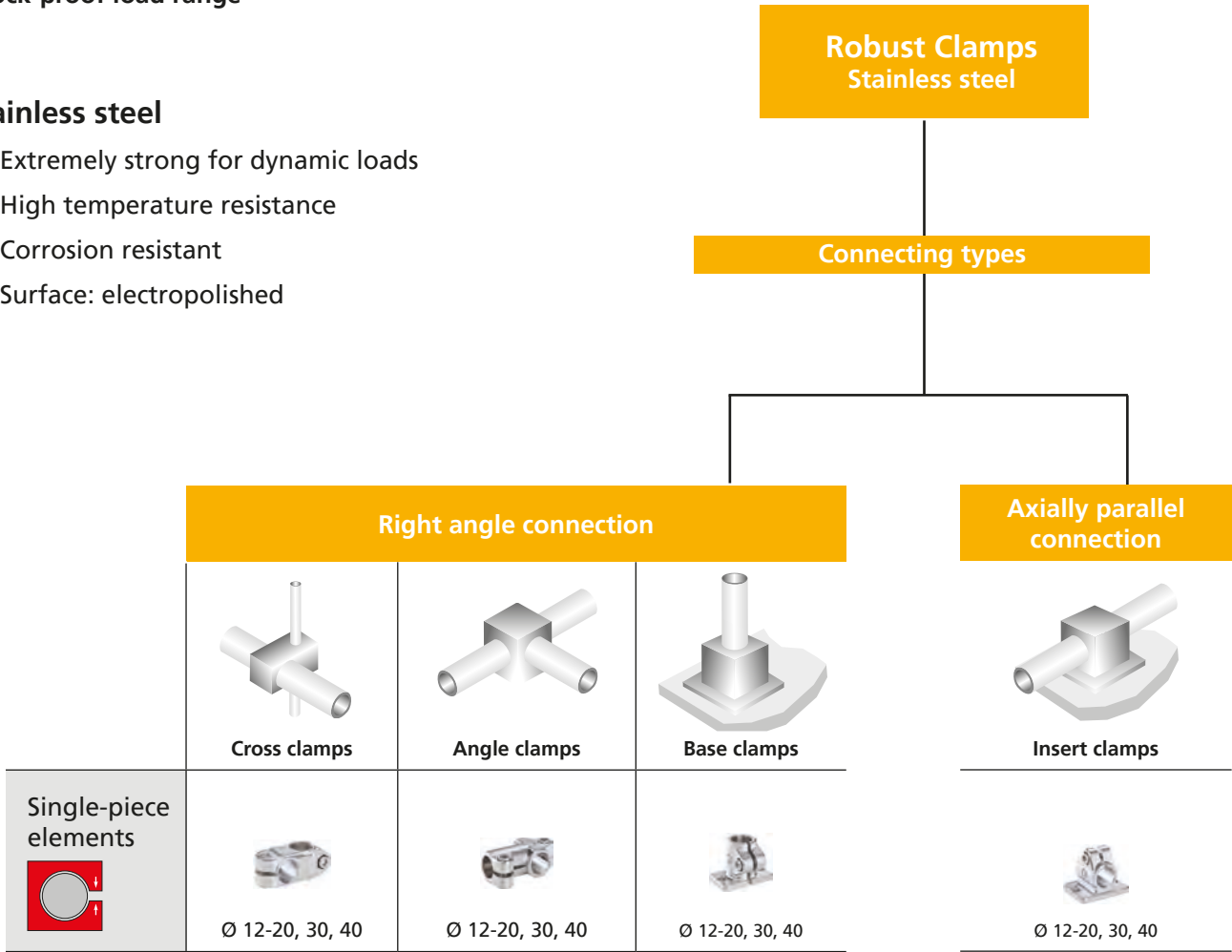















EMS – stainless steel mounting system

EMS round tube connectors				
EMS WIT R 40	EMS WI R 40	EMS WIE R 40	EMS KI R 40	EMS FI R 40
S. 223	S. 223	S. 223	S. 224	S. 224

EMS square tube connectors				
EMS WIT V 40	EMS WI V 40	EMS WIE V 40	EMS KI V 40	EMS FI V 40
S. 227	S. 227	S. 227	S. 228	S. 228

























Ø = Diameter round tube
 □ = Dimension square tube









Accessories: Light-, Solid- & Robust Clamps				
 <p>Steel tubes $\varnothing = 12-80$ $\square = 20-80$</p>	 <p>Round tube stopper</p>	 <p>Adjustable foot</p>	 <p>Swivel castor with tube fitting</p>	 <p>Press nut</p>
 <p>Stainless steel tubes $\varnothing = 12-60$ $\square = 20-80$</p>	 <p>Square tube stopper</p>	 <p>Adjustable feet with tube fitting</p>	 <p>Fixed castor with tube fitting</p>	 <p>Adapter sleeve R28</p>
 <p>Aluminium tubes $\varnothing = 20-60$ $\square = 20-60$</p>	 <p>Round tube threaded stopper</p>	 <p>Square tube threaded stopper</p>	 <p>Adjustable levers</p>	
 <p>Aluminium bars $\varnothing = 8-10, \square = 10$</p>				







Selection guide

ITAS - Industrial stairs and working platforms

- No drilling or welding
- No bevel cut
- Easy installation
- Pleasing design

Internal tension system							
MI 40 p. 254		WIT 40-45° p. 256		WIV 40-45° p. 258	 Stair railing support TGHF p. 249		
WI 40 p. 254		WIT 40H-45° p. 256		WIY 40-45° p. 258		TSI 40-WI p. 261	
WIT 40 p. 254		KI 40-45° p. 257		MIG 40 RR p. 259		TSI p. 261	
WIE 40 p. 255		KI 40H-45° p. 257		MIG 40 RZ p. 259			
WITE 40 p. 255		WIT 40H-45°R p. 257		MIG 40 ZZ p. 259			
KI 40 p. 255		WIT 40H-45°L p. 258		FIW 40 p. 260			
WI 40-45° 30°, 38°, 52°, 60° p. 256		WIV 40H-45° p. 258		FI 40 p. 260			

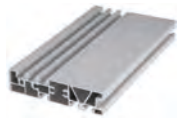
Quick change system					
MI-H 40-SW p. 264		WIT 40-SW2 p. 265		WITE 40-SW2 p. 266	
WI 40-SW1 p. 264		KI 40-SW2 p. 265		WIT 40H-45°SW1 p. 266	
WIT 40-SW1 p. 264		WIE 40-SW2 p. 265		KI 40H-45°SW1 p. 266	

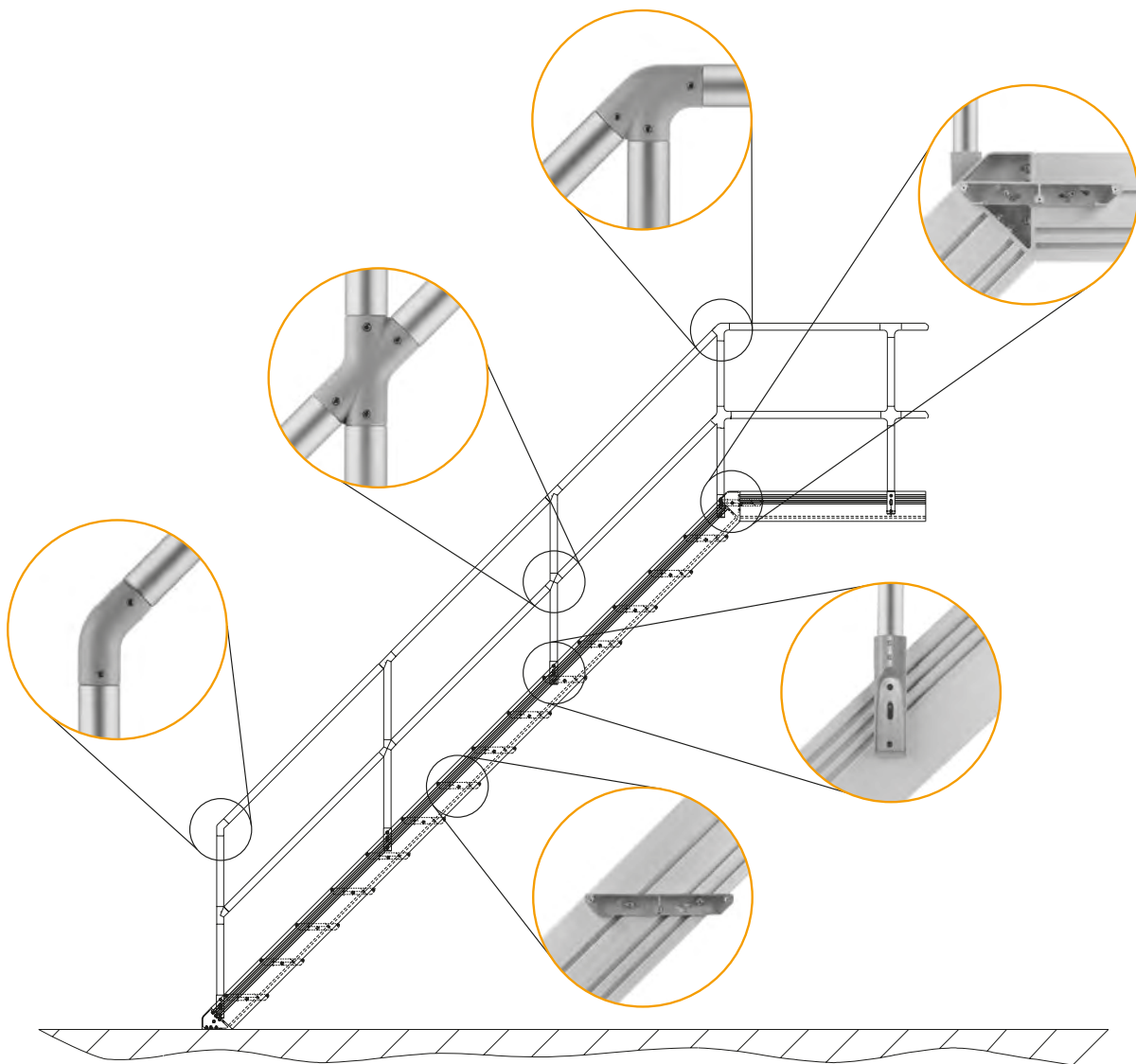

ITAS Accessories			
<p>Aluminium tube Ø 40x3</p>  <p>p. 268</p>	<p>Angle plate for TGHF</p>  <p>p. 270</p>	<p>Step profile</p>  <p>p. 272</p>	<p>Stair joint</p>  <p>p. 274</p>
<p>Surface element support FEH-I 40</p>  <p>p. 269</p>	<p>Stair cross beam profile</p>  <p>p. 271</p>	<p>Side plate</p>  <p>p. 273</p>	<p>Stair corner joint</p>  <p>p. 275</p>



RK Monitor Mounting

RK Monitor Mounting					
for round steel tubes, square tubes or profiles	Rotary flange monitor mounting  S. 282	Ball joint monitor mounting  S. 282	Monitor mounting compact  S. 283		
	Console monitor mounting  S. 284	Dual-ball monitor mounting  S. 285	Dual-ball pivoting monitor mounting  S. 285	Wall console  S. 286	Profile console  S. 286
	Support arm single  S. 287	Support arm double  S. 288	Support arm double height adjustable  S. 289	Support arm telescope  S. 290	Support arm telescope height adjustable  S. 292
	Adaptor plate VESA 50/75  S. 306	Adaptor plate VESA 75/100  S. 306	Keyboard tray  S. 307	Notebook holder  S. 308	Tablet holder  S. 309
	Smartphone holder  S. 310	Lockable swivel castor  S. 311	More Accessories  ab S. 311		

Modules / Monitor floor stands

Monitor floor stand adjustable	Monitor floor stand stationary
 S. 294	 S. 298



Our selection guide is also available online!

Our online selection guide Connecting technology - including:

- **Tube connectors plastic**
(Light Clamps - light load range)
- **Tube connectors aluminium**
(Solid Clamps - medium to heavy load range)
- **Tube connectors stainless steel**
(Robust Clamps - shock-proof load range)
- **EMS – stainless steel mounting system**
(for frame structures in the food industry)
- **ITAS**
(Industrial stairs and working platforms)
- **Monitor Mounting**
(All purpose mounting for monitors)

can be found on our website

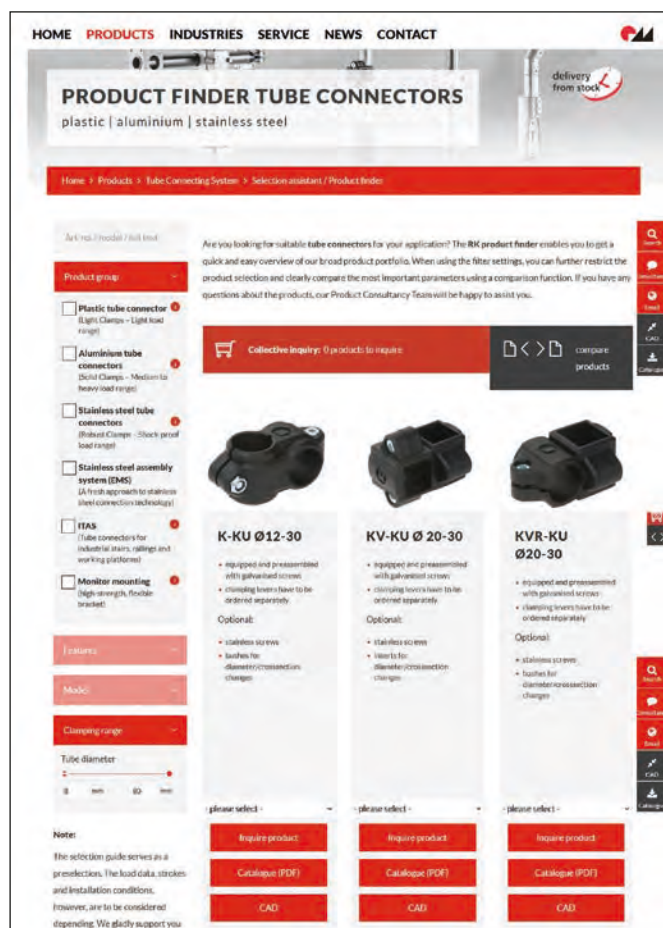

Only four steps to our product recommendation

- Easy to select
- Online link to current PDF-catalogues
- CAD-data
- Shopping cart function for inquiries
- Products compare

It can be easier than that...
...just try it.

RK Light Clamps

Light load range

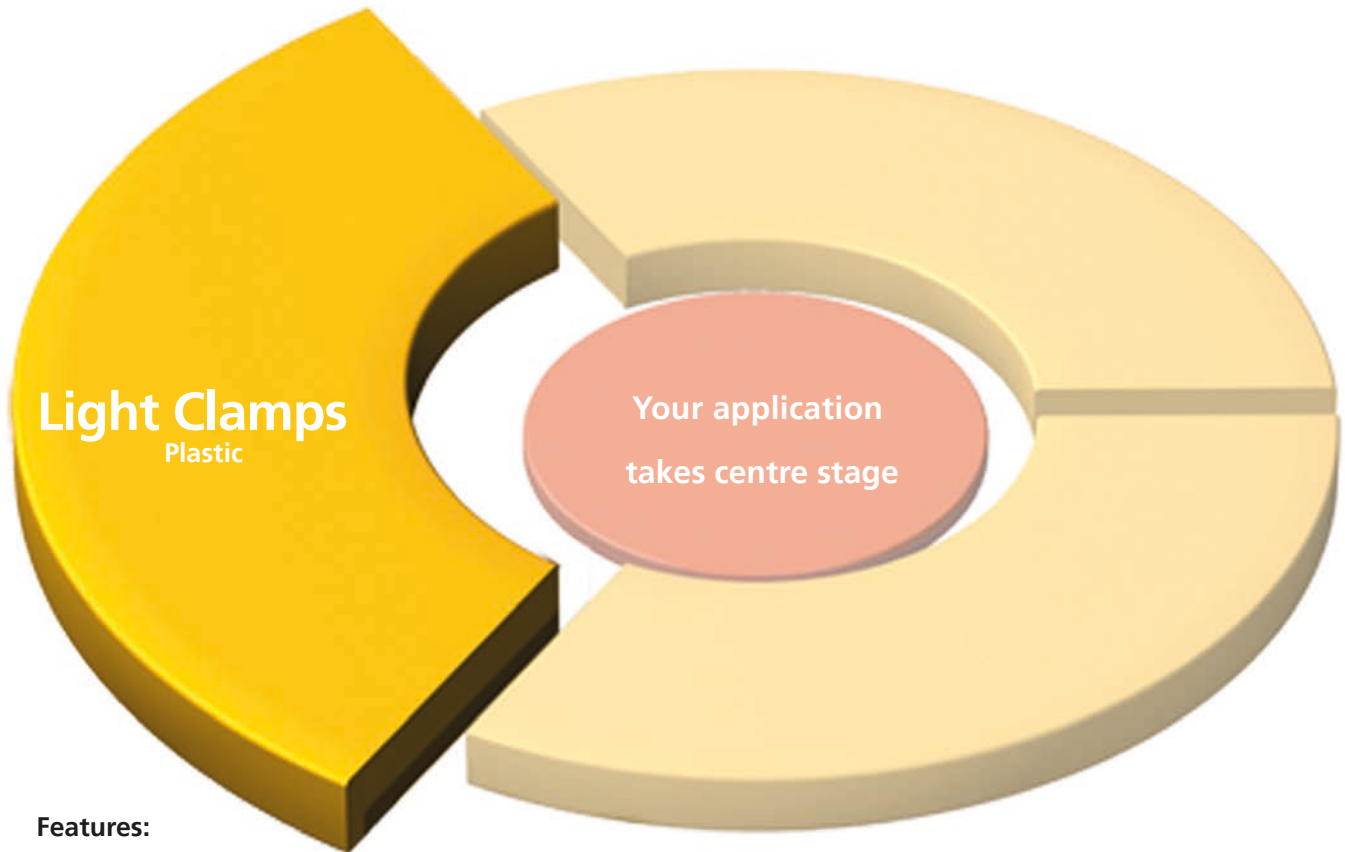

Features:

- Easy
- Good value
- Variable

...the constructive plastic element connecting technology

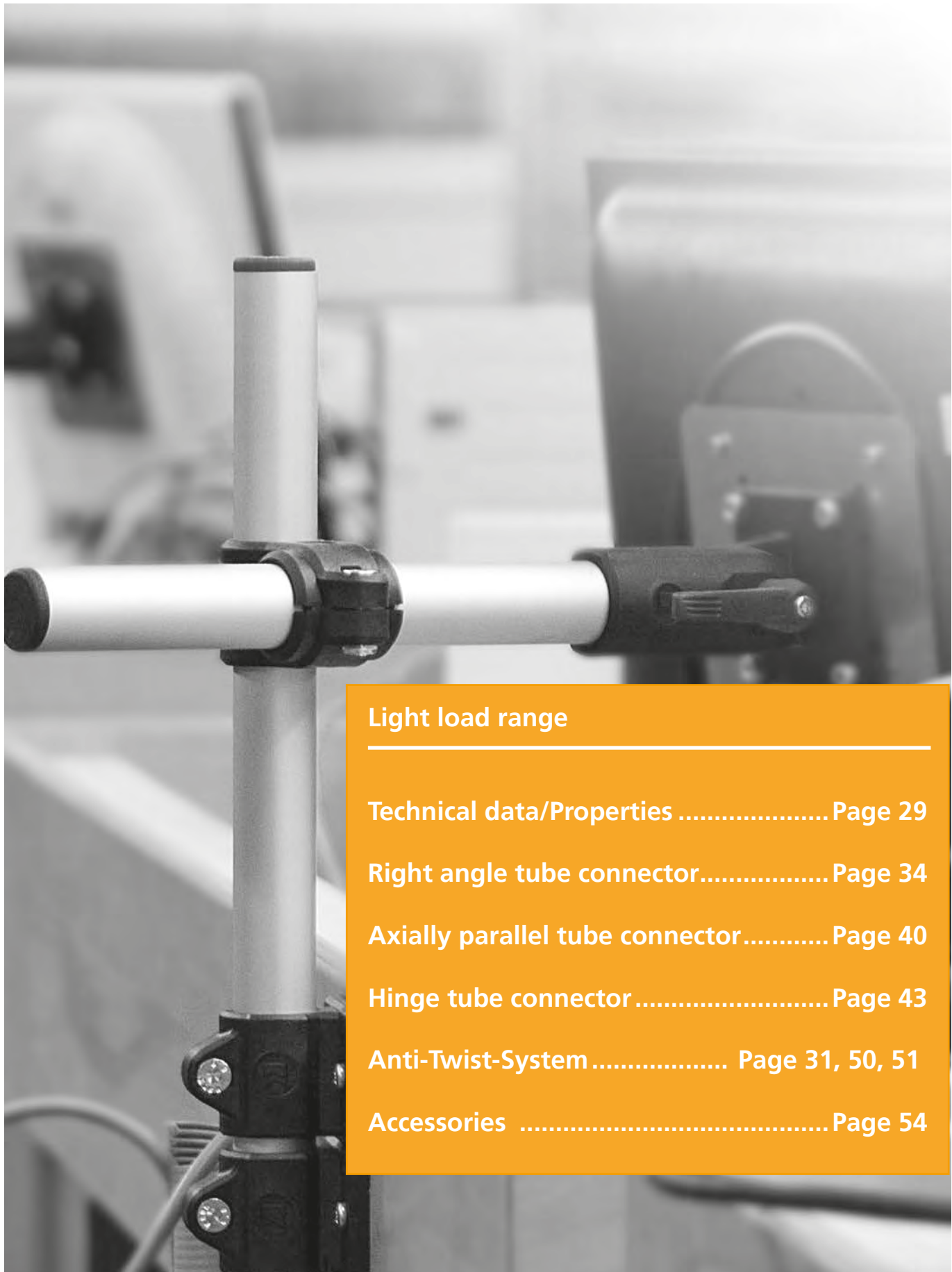

Light load range

Technical data/Properties Page 29

Right angle tube connector..... Page 34

Axially parallel tube connector..... Page 40

Hinge tube connector Page 43

Anti-Twist-System Page 31, 50, 51

Accessories Page 54

RK Light Clamps

Light load range

...the constructive plastic element connecting technology

• Right angle tube connector

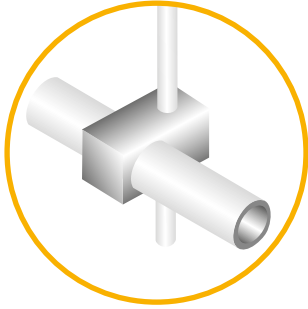

Cross clamps

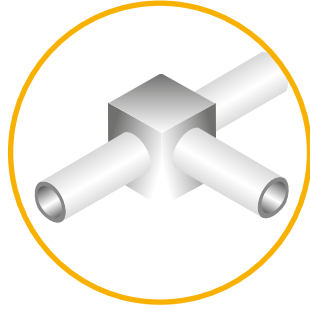

Angle clamps

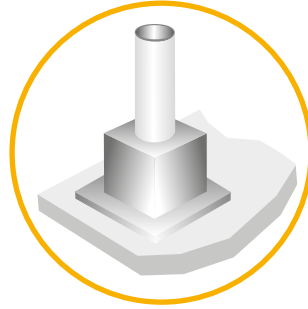

Base clamps

• Axially parallel tube connector

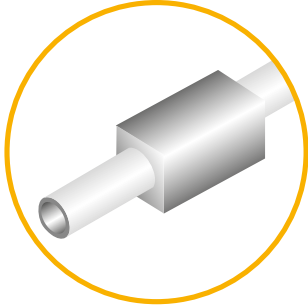

Sleeve clamps

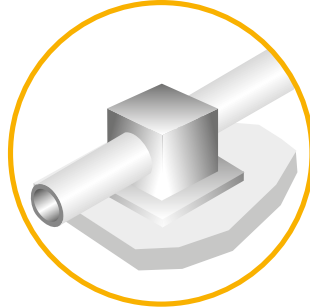

Flange clamps

• Hinge tube connector

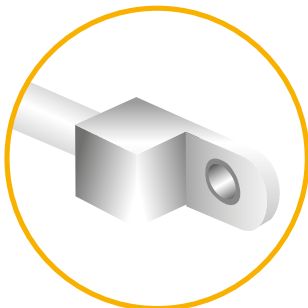

Strap clamps

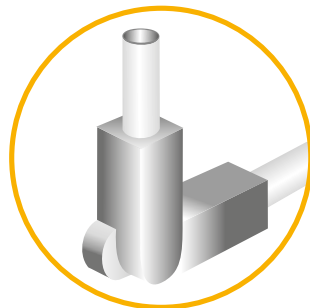

Hinge clamps

• Ball joint tube connector

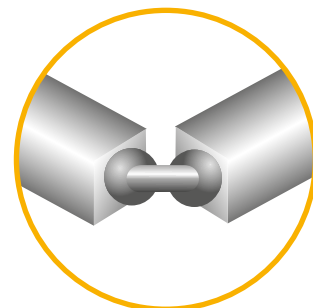

Light clamps ball joint

Table of contents

Right angle tube connector (Single-pcs and multi-pcs elements)	Cross clamps p. 34 Angle clamps p. 36 Base clamps p. 38
Axially parallel tube connector (Single-pcs and multi-pcs elements)	Sleeve clamps p. 40 Flange clamps p. 41
Hinge tube connector (Single-pcs and multi-pcs elements)	Strap clamps p. 43 Hinge clamps p. 45 Ball joint clamps p. 38
Anti-Twist-System	Operating principle p. 31 Anti-rotation (R-clip), slot profile..... p.31
Accessories	Reducing bushes Ø p. 54 Reducing insert □ p. 54 Clamping lever p. 55 Screws – Zinc-plated steel p. 55 Screws – Stainless steel p. 55
Properties	Resistance to chemicals p. 56

RK Light Clamps

Light load range

Version:

- Light Clamps



Single-piece elements

- For faster and more economic assembly



Multi-piece elements

- For add-on assembly and upgrading



Features:

- Only one element per type (Ø18 / Ø30 / □ 30)
- Elements made of reinforced polyamide
- Closed elements or half cups
- Tube clamping of different diameters or sections due to a special bush system. Every bush form is worked with the needed tube diameter. Two basic diameters can be flexibly adapted with reducing bushes

- Anti turning device for the bush former due to a lokation pin in the bush
- Attractive design, low dead load
- Zinc plated screws
- Restistance against corrosion and agresive substances. Applicable e.g. in the food packaging industry
- Compatibility to the BLOCAN® profile system

Options:

- Equipped with stainless steel screws for usage in the food industry and the wet areas in the beverage industry



Loads

Attention!

The data in the chart do not ensure a guarantee of quality or a warrant characteristic of our products. These are nonbinding standard values which might be not reached in individual cases due to the temperature or surface finish of the clamping profile.

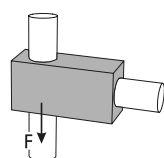

Adhesion force F [kN]

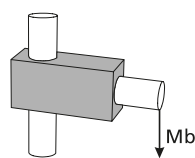

Bending moment Mb [Nm]

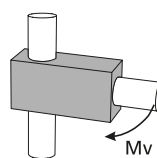

Twisting moment Mv [Nm]

Tightening torque max:

Sizes: 10 – 18: 2,5 Nm

Sizes: 20 – 30: 8,0 Nm

Material data sheet available upon request.

Sizes Type	□10			Ø12 - 18			□20			Ø20 - 30			□30			Ø30		
	F	Mb	Mv	F	Mb	Mv	F	Mb	Mv	F	Mb	Mv	F	Mb	Mv	F	Mb	Mv
Cross clamps																		
K-KU	0,30	130	15	0,50	111	5	0,50	164	31	1,00	184	11,50						
KV-KU													1,30	122	23	1,60	120,50	19
KVR-KU Insert													1,40	136	23	1,60	142,50	19
KVR-KU Bushes													0,60	134,50	30,50	1,80	107,50	19
Angle clamps																		
W-KU	0,20	91	8	0,60	83	4,50	0,60	153,50	30	1,00	177	10,50						
WV-KU													1,00	136,50	23	1,40	109,50	15,50
Base clamps																		
FS-KU	0,20	36	11	0,40	40	2,50	0,60	158	31	1,10	181,50	13						
FV-KU													1,00	77	23	1,60	72	19,50
Sleeve clamps																		
M-KU	0,10	91	8	0,50	75,50	4	0,70	225,50	31	1,00	242,50	11,50						
Flange clamps																		
FK-KU	0,20	35	7,50	0,40	38,50	4	0,60	134,50	31	1,20	137,50	12,50						
FKV-KU													1,30	144,50	23	1,60	142,50	20,50
V-KU													0,90	-	23	1,20	-	15,50
Strap clamps																		
LP-KU	0,30	16	7,50	0,40	18,50	4,50	0,70	38,50	27	0,90	41,50	11,50						
LPZ-KU	0,40	16	7,50	0,50	18,50	2,50	0,70	43	28	0,90	45,50	12						
LW-KU	0,20	27,50	7,50	0,70	27,50	4	0,80	40,50	31	1,10	41	14						
LF-KU																		

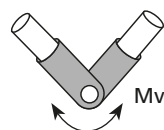

Twisting moment Mv [Nm]

Sizes Type	□10		Ø12 - 18		□20		Ø20 - 30		□30		Ø30	
		Mv		Mv		Mv		Mv		Mv		Mv
Hinge clamps												
GW-KU without tothing		1,50		1,70		4,00		4,20				
GWZ-KU with tothing												
GP-KU without tothing		1,10		1,50		2,50		2,10				
GPZ-KU with tothing												
GF-KU without tothing												
GFZ-KU with tothing		27		23		68		68				

RK Light Clamps

Light load range

Reducing bushes / -insert size

You can choose the size of the insert you want to introduce into the clamping element between 10 and 25 mm.

The basic size of the round tubular connections is either 18 or 30mm. For any other required diameter the corresponding reducing bush can be delivered.

Should you work with square tubes, which offer a choice between 10 and 20 mm, reducing bushes are a necessity.

Order instruction and accessories

The clamping elements are automatically provided with a zinc-plated fixation screw. Also, stainless steel screws and plastic levers can be optionally ordered for the fixation.

The reducing bushes and -inserts are not included in the standard delivery. They are separately listed in the accessory chapter.

Applications:

- Areas of the laboratory technology
- Food industry
- Wet area in the beverage industry
- Photo technical applications

Reducing bushes / -insert form

Not only can you choose the diameter of the reducing bush you require, you also have the possibility to choose its form. All you need to do is to choose the tube section you would like to work with.

The following forms are at your disposal:

1. For round tubes \emptyset
2. For square tubes \square

Detailed information for the reducing bushes and inserts can be found in the chapter accessories page 52

The variable reduction sleeve concept :

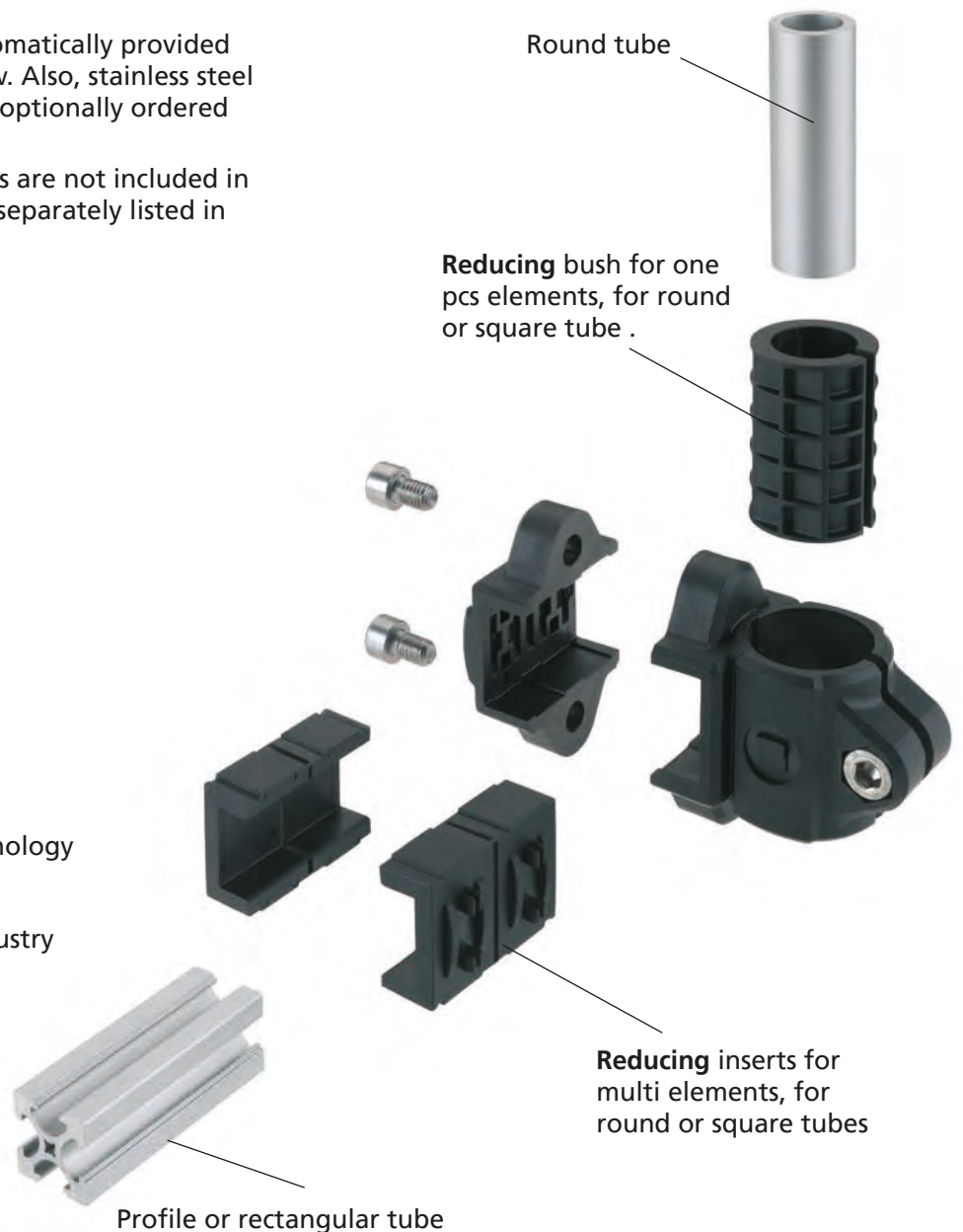

The illustration shows an element of type KVR. This element is a half-cup element.

Anti-Twist-System

Anti-rotation for RK Light Clamps – single-piece

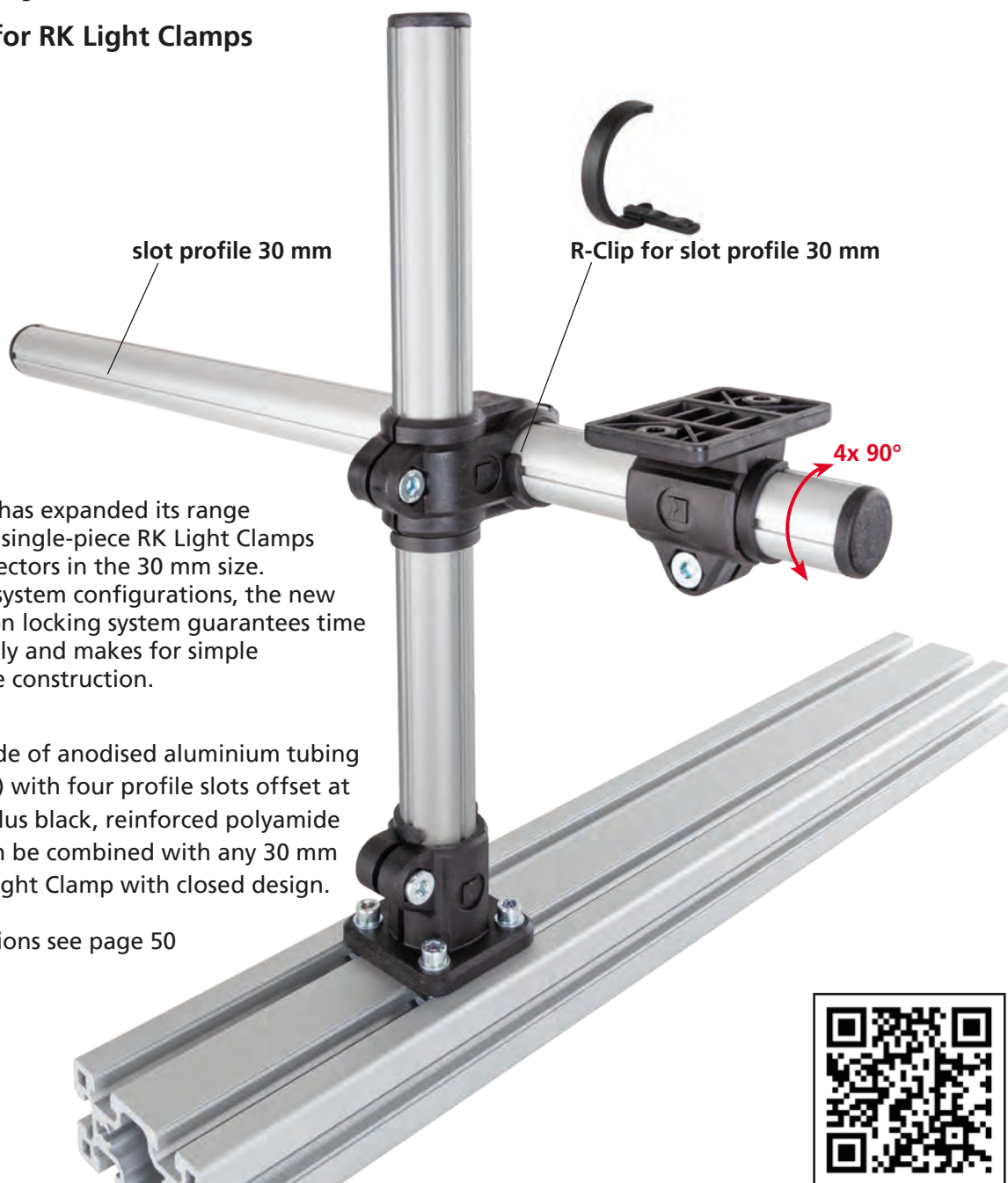
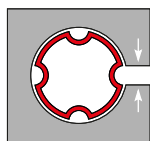

RK Rose+Krieger has expanded its range of accessories for single-piece RK Light Clamps plastic tube connectors in the 30 mm size. When used with system configurations, the new Anti-Twist rotation locking system guarantees time savings in assembly and makes for simple adjustment of the construction.

The system is made of anodised aluminium tubing (30 mm diameter) with four profile slots offset at an angle of 90° plus black, reinforced polyamide plastic clips. It can be combined with any 30 mm single-piece RK Light Clamp with closed design.

Ordering instructions see page 50



Video
How it works
Anti-Twist-System

Your added value:

- Safe** - anti-rotation in 90° steps
- Stable** - absorption of up to three times higher torsional moments
- Fast** - Significant time savings during assembly
- Efficient** - Complex systems can be assembled by one person
- Simple** - Clips can be mounted without tools
- Compatible** - Can be used with closed RK Light Clamps Ø 30

It's that easy:

- Slide the pipe connector onto the groove profile
- Pre-position the tube connectors axially
- Push the clips by hand onto the groove profile into the pipe connectors
- Tighten the clamping screw - done!

Overview

Right angle tube connector



Axially parallel tube connector



Hinge tube connector

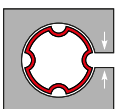

Usable for
Anti-Twist-System



RK Light Clamps

Cross clamps

Order instruction:

- Purchase only in lot sizes and a multiple of that, see product table below
- Inserts and bushes for diameter/cross-section changes see accessories page 54
- Standard: equipped and preassembled with galvanised screws
- Clamping levers have to be ordered separately, delivery unassembled
See table last column and page 55

On request:

- Stainless screws



Anti-twist system
applicable with Type 30

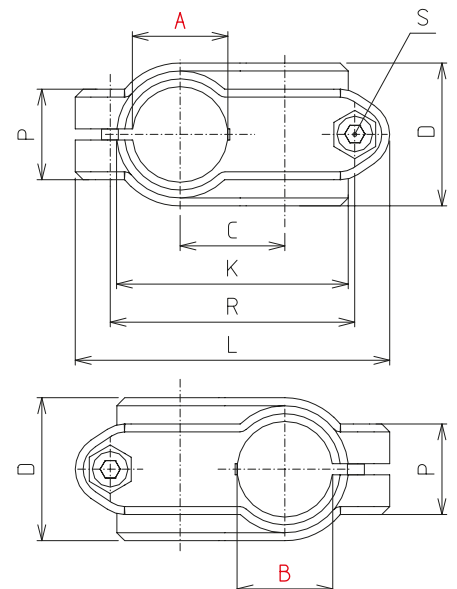

Cross clamp K-KU

[mm]

Code No.	Type	lot sizes	Clamping *		C	D	K	L	P	R	Weight m [g]	Clamping lever S Code No.
			A	B								
K00018ACSR18R18	12-18	10, 20, 30... pcs	18		20	30	48	63	21	48	50	93024
K00030ACSR30R30	20-30	5, 10, 15... pcs	30		33	45	72	99	28,5	77	132	902381

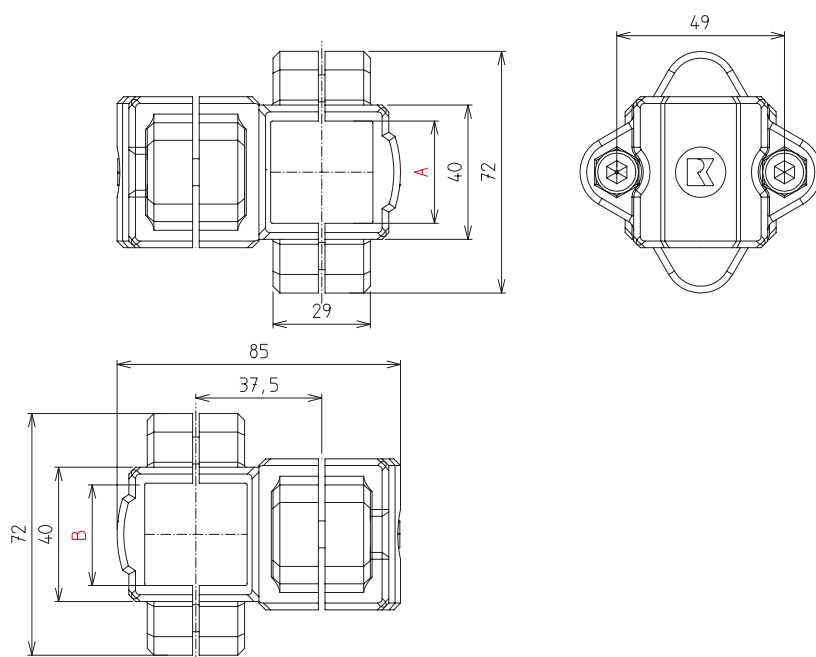

Cross clamp KV-KU

Code No.	Type	lot sizes	Clamping*		Weight m [g]
			A	B	
K00530ACSV30V30	20-30	5, 10, 15... pcs	30		171

[mm]



Anti-twist system applicable with Type 30

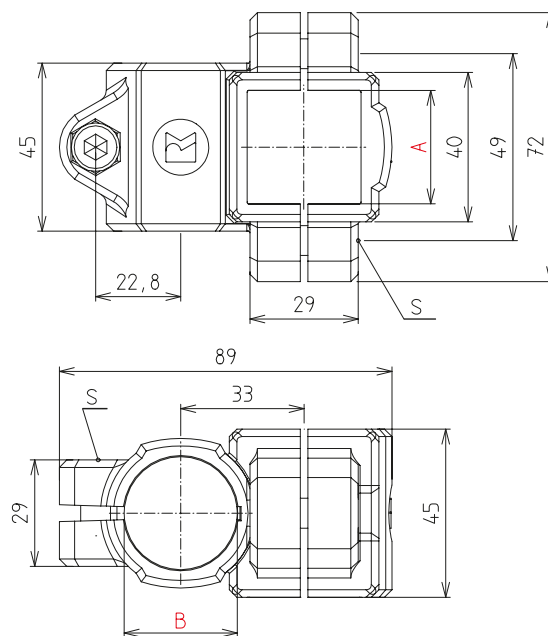

Cross clamp KVR-KU

Code No.	Type	lot sizes	Clamping*		Weight m [g]
			A	B	
K00430ACSR30V30	20-30	5, 10, 15... pcs	30		117

[mm]

*Reduction of the diameter or cross section of the clamping with bushes possible (Accessories p. 54).

RK Light Clamps

Angle-/Base clamps

Order instruction:

- Purchase only in lot sizes and a multiple of that, see product table below
- Inserts and bushes for diameter/cross-section changes see accessories page 54
- Standard: equipped and preassembled with galvanised screws
- Clamping levers have to be ordered separately, delivery unassembled See table last column and page 55

On request:

- Stainless screws

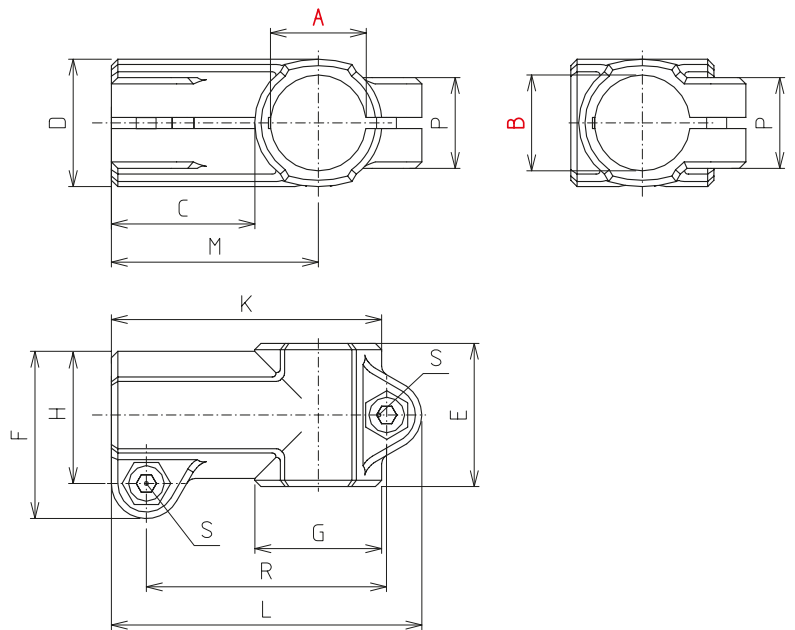

Anti-twist system applicable with Type 30



Angle clamps W-KU

Code No.	Type	lot sizes	Clamping*		[mm]													Weight m [g]	Clamping lever S Code No.
			A	B	C	D	E	F	G	H	K	L	M	P	R				
K10018ACSR18R18	12-18	10, 20, 30... pcs	18		30,5	25	30	34	25	26,5	55,5	64,5	43	21	49,5	44	93024		
K10030ACSR30R30	20-30	5, 10, 15... pcs	30		45	40	45	52,5	40	41,5	85	97,5	65	28,5	75,5	115	902381		



Anti-twist system applicable with Type 30

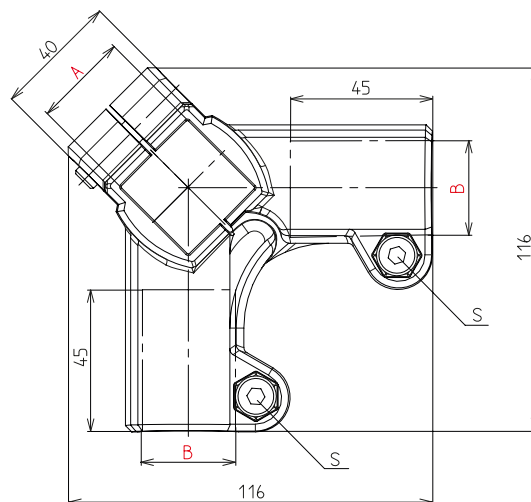
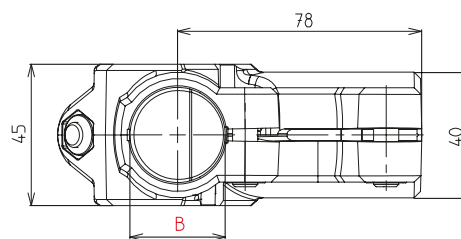

Angle clamps WER-KU

[mm]

Code No.	Type	lot sizes	Clamping *		Weight m [g]	Clamping lever S Code No.
			A	B		
K10630ACSR30R30V30	20-30	4, 8, 12... pcs	30,1	30,3	189	902381

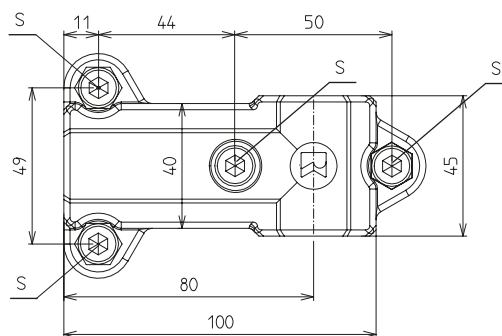
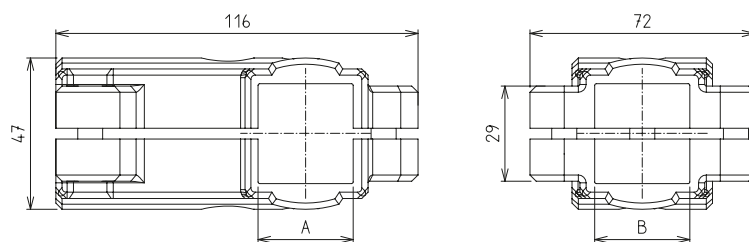

Angle clamps WV-KU

[mm]

Code No.	Type	lot sizes	Clamping *		Weight m [g]	Clamping lever S Code No.
			A	B		
K10430ACSV30V30	20-30	5, 10, 15... pcs	30		194	902381

RK Light Clamps

Angle-/Base clamps

Order instruction:

- Purchase only in lot sizes and a multiple of that, see product table below
- Inserts and bushes for diameter/cross-section changes see accessories page 54
- Standard: equipped and preassembled with galvanised screws
- Clamping levers have to be ordered separately, delivery unassembled
See table last column and page 55

On request:

- Stainless screws



Anti-twist system applicable with Type 30



FS-KU 18/2

* Dimension of K are turned by 90° with a distance of 38-40 mm (slotted hole)

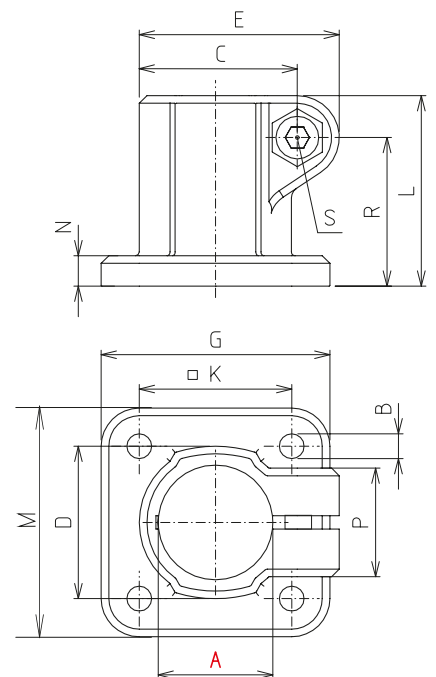

Base clamps FS-KU

[mm]

Code No.	Type	lot sizes	Clamping* A	B	C	D	E	G	K	L	M	N	P	R	Weight m [g]	Clamping lever S Code No.
K30018ACSR18	12-18	10, 20, 30... pcs	18	5,3	26,5	26	34	45	30	32	45	5	21	24,5	30	93024
K30118ACSR18	18/2	10, 20, 30... pcs	18	5,5	26,5	26	34	30	38	32	50	5	21	18,5	30	93024
K30030ACSR30	20-30	5, 10, 15... pcs	30	6,5	41,5	40	52,5	60	40	50	60	8	28,5	39	75	902381

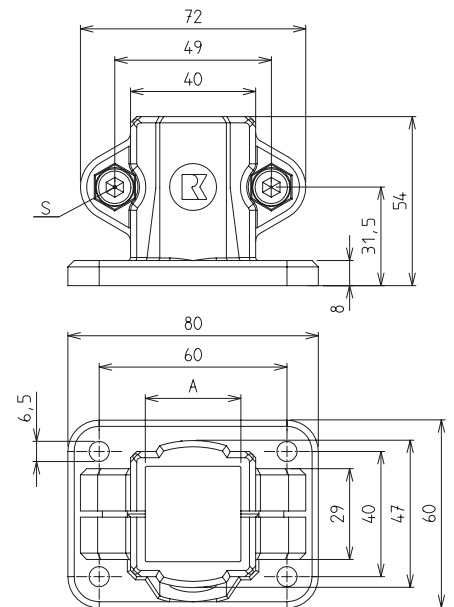

Base clamps FV-KU

Code No.	Type	lot sizes	Clamping * A	Weight m [g]	Clamping lever S Code No.
K30530ACSV30	20-30	5, 10, 15... pcs	30	121	902381

*Reduction of the diameter or cross section of the clamping with bushes possible (Accessories p. 54).

RK Light Clamps

Sleeve-/Flange clamps

Order instruction:

- Purchase only in lot sizes and a multiple of that, see product table below
- Inserts and bushes for diameter/cross-section changes see accessories page 54
- Standard: equipped and preassembled with galvanised screws
- Clamping levers have to be ordered separately, delivery unassembled
See table last column and page 55

On request:

- Stainless screws



Anti-twist system
applicable with Type 30

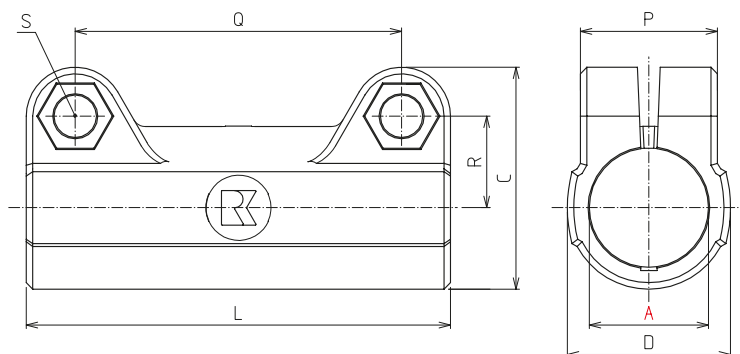

Sleeve clamp M-KU

[mm]

Code No.	Type	lot sizes	Clamping*		C	D	L	P	Q	R	Weight m [g]	Clamping lever S Code No.
			A	B								
K40018ACSR18R18	12-18	10, 20, 30... pcs	18		34	25	65	21	50	14	28	93024
K40030ACSR30R30	20-30	5, 10, 15... pcs	30		52,5	40	95	28,5	73	22,8	87	902381



Anti-twist system applicable with Type 30

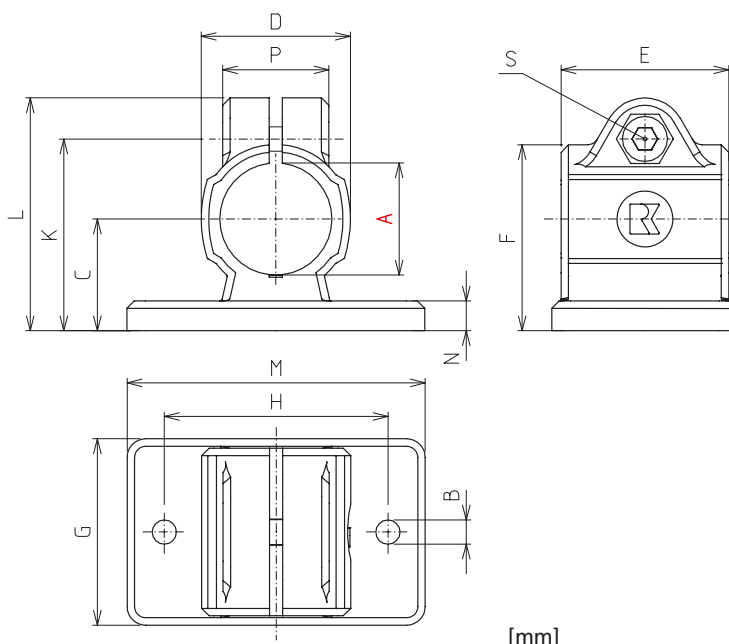
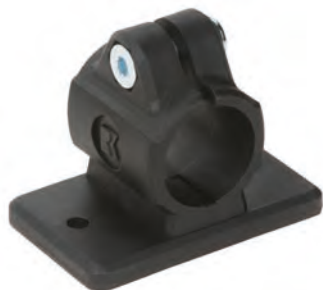

[mm]

Flange clamp FK-KU

Code No.	Type	lot sizes	Clamping* A	B	C	D	E	F	G	H	K	L	M	N	Weight m [g]	Clamping lever S Code No.
K20018ACSR18	12-18	10, 20, 30... pcs	18	5,3	18	25	30	30,5	35	40	32	39,5	50	5	30	93024
K20030ACSR30	20-30	5, 10, 15... pcs	30	6,5	30	40	45	50	50	60	52,8	62,5	80	8	84	902381

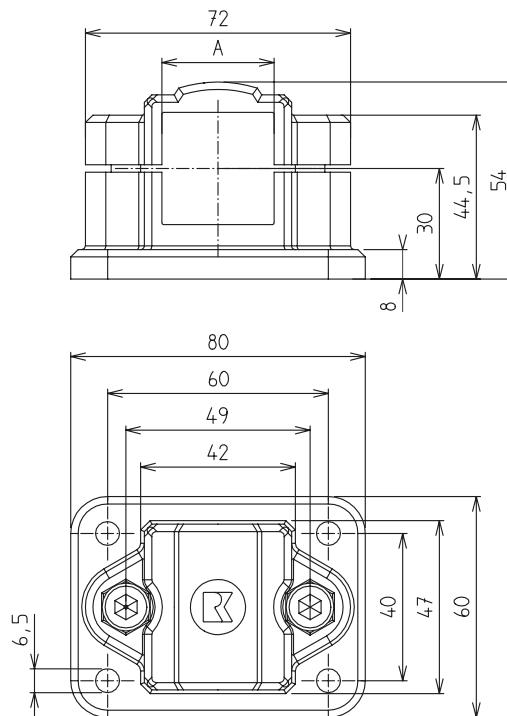

[mm]

Flange clamp FKV-KU

Code No.	Type	lot sizes	Clamping* A	Weight m [g]
K20530ACSV30	20-30	5, 10, 15... pcs	30	125

*Reduction of the diameter or cross section of the clamping with bushes possible (Accessories p. 54).

RK Light Clamps

Flange-/Strap clamps

Order instruction:

- Purchase only in lot sizes and a multiple of that, see product table below
- Inserts and bushes for diameter/cross-section changes see accessories page 54
- Standard: equipped and preassembled with galvanised screws
- Clamping levers have to be ordered separately, delivery unassembled See table last column and page 55

On request:

- Stainless screws

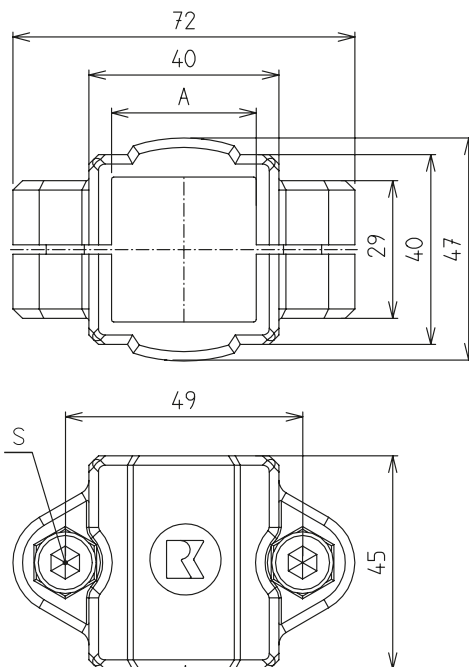

Flange clamp V-KU

[mm]					
Code No.	Type	lot sizes	Clamping * A	Weight m [g]	Clamping lever S Code No.
K20830ACSV30	20-30	5, 10, 15... pcs	30	90	902381



 Anti-twist system applicable with Type 30



15° tooting, internal

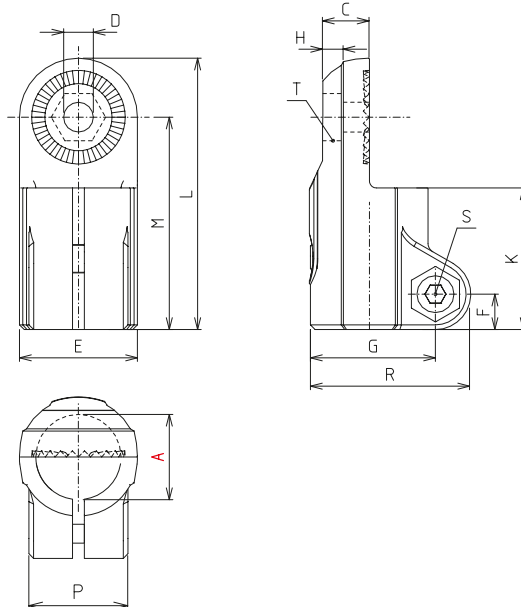

Strap clamp LP-KU

Code No.	Type	lot sizes	Clamping* A	C	D	E	F	G	H	K	L	M	P	R	T	Weight m [g]	Clamping lever S Code No.
K70118ACSR18	12-18	10, 20, 30... pcs	18	9,9	6,1	25	7,5	26,5	5,9	30	57,5	45	21	34	M6-DIN985	28	93024
K70130ACSR30	20-30	5, 10, 15... pcs	30	16,5	8,1	40	11	41,5	9,9	45	88	68	28,5	52,5	M8-DIN985	86	902381

[mm]

 Anti-twist system applicable with Type 30



15° tooting, external

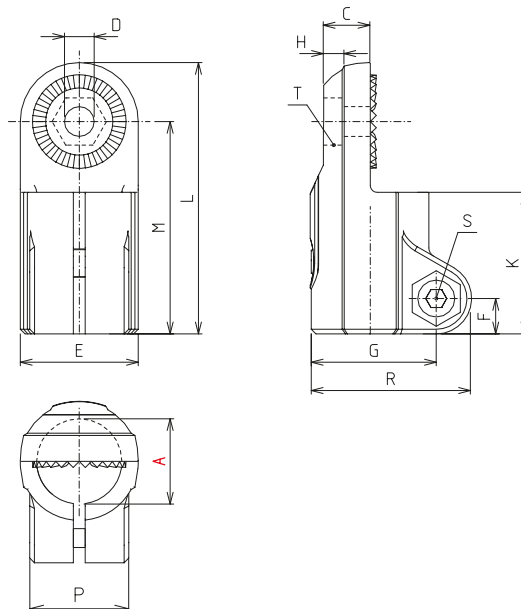

Strap clamp LPZ-KU

Code No.	Type	lot sizes	Clamping* A	C	D	E	F	G	H	K	L	M	P	R	T	Weight m [g]	Clamping lever S Code No.
K71018ACSR18	12-18	10, 20, 30... pcs	18	9,9	6,1	25	7,5	26,5	5,9	30	57,5	45	21	34	M6-DIN985	28	93024
K71030ACSR30	20-30	5, 10, 15... pcs	30	16,5	8,1	40	11	43	9,9	45	88	68	28,5	52,5	M8-DIN985	87	902381

[mm]

*Reduction of the diameter or cross section of the clamping with bushes possible (Accessories p. 54).

RK Light Clamps

Strap-/Hinge clamps

Order instruction:

- Purchase only in lot sizes and a multiple of that, see product table below
- Inserts and bushes for diameter/cross-section changes see accessories page 54
- Standard: equipped and preassembled with galvanised screws
- Clamping levers have to be ordered separately, delivery unassembled See table last column and page 55

On request:

- Stainless screws



Anti-twist system applicable with Type 30



15° tooting, internal

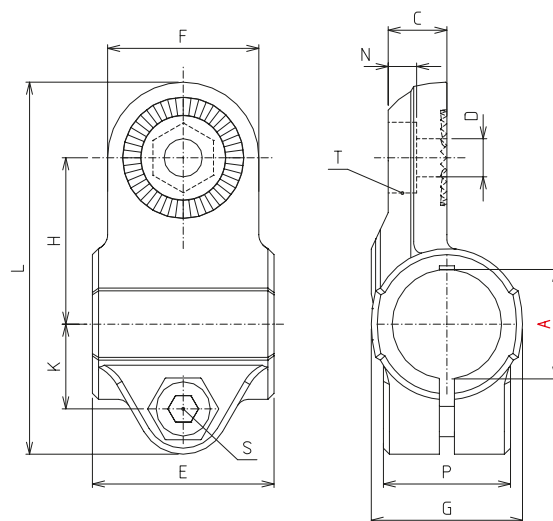

Strap clamp LW-KU

Code No.	Type	lot sizes	Clamping* A	C	D	E	F	G	H	K	L	M	P	T	[mm]	
															Weight m [g]	Clamping lever S Code No.
K70018ACSR18	12-18	10, 20, 30... pcs	18	9,7	6,1	30	25	25	27,5	14	61,5	5,7	21	M6-DIN985	29	93024
K70030ACSR30	20-30	5, 10, 15... pcs	30	16,5	8,1	45	40	40	43	21,5	95,5	9,9	28,5	M8-DIN985	91	902381



15° tooting, internal

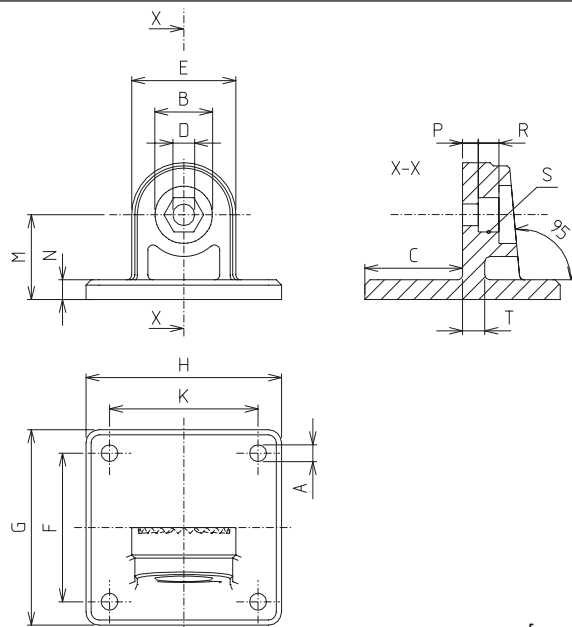

Strap clamp LF-KU

Code No.	Type	lot sizes	A	B	C	D	E	F	G	H	K**	M	N	P	R	S	T	[mm]	
																		Weight m [g]	
K70218ACS	12-18	10, 20, 30... pcs	5,3	15	25	6,1	25	40	50	35	0	20	5	4,5	5,5	M6-DIN985	5	17	
K70230ACS	20-30	5, 10, 15... pcs	6,5	22	37,5	8,1	40	60	75	75	60	32,5	7,5	6,6	8,2	M8-DIN985	7	77	

** For Type 12-18, only 2 bores (centered) available.

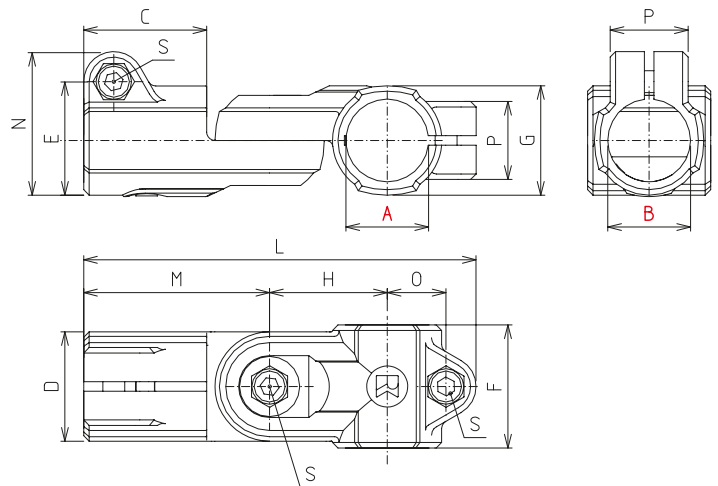
Anti-twist system
 applicable with Type 30

Hinge clamp GW-KU (without tothing) GWZ-KU (with tothing)

[mm]

Code No.	Type	lot sizes	Clamping *		C	D	E	F	G	H	L	M	N	O	P	Weight m [g]	Clamping lever S Code No.
			A	B													
K80118ACS- R18R18	GW 12-18	10, 20, 30... pcs	18		30	25	26,5	30	25	27,5	94	45	34	14	21	67	93024
K80418ACS- R18R18	GWZ 12-18	10, 20, 30... pcs	18		30	25	26,5	30	25	27,5	94	45	34	14	21	67	93024
K80130ACS- R30R30	GW 20-30	5, 10, 15... pcs	30		45	40	41,5	45	40	43	143,5	68	52,5	32,5	28,5	177	902381
K80430ACS- R30R30	GWZ 20-30	5, 10, 15... pcs	30		45	40	41,5	45	40	43	143,5	68	52,5	32,5	28,5	178	902381

GW – without tothing, 180° infinitely
 GWZ – with tothing, rotation of 180°, 15° intervals

*Reduction of the diameter or cross section of the clamping with bushes possible (Accessories p. 54).

RK Light Clamps

Hinge clamp

Order instruction:

- Purchase only in lot sizes and a multiple of that, see product table below
- Inserts and bushes for diameter/cross-section changes see accessories page 54
- Standard: equipped and preassembled with galvanised screws
- Clamping levers have to be ordered separately, delivery unassembled
See table last column and page 55

On request:

- Stainless screws



Anti-twist system applicable with Type 30

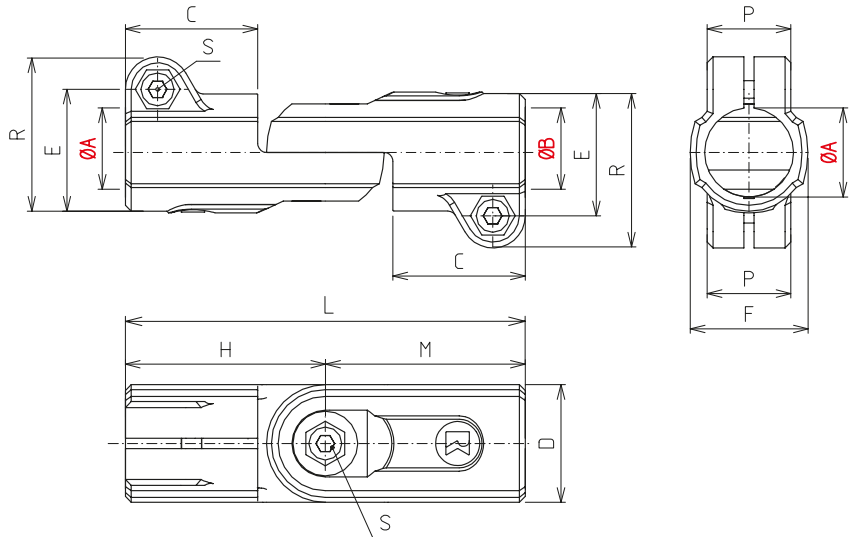

Hinge clamp GP-KU (without tothing) GPZ-KU (with tothing)

[mm]

Code No.	Type	lot sizes	Clamping*		C	D	E	F	H	L	M	P	R	Weight m [g]	Clamping lever S Code No.
			A	B											
K80018ACSR18R18	GP 12-18	10, 20, 30... pcs	18		30	25	26,5	30	45	90	45	21	34	66	93024
K80518ACSR18R18	GPZ 12-18	10, 20, 30... pcs	18		30	25	26,5	30	45	90	45	21	34	66	93024
K80030ACSR30R30	GP 20-30	5, 10, 15... pcs	30		45	40	41,5	40	68	136	68	28,5	52,5	194	902381
K80530ACSR30R30	GPZ 20-30	5, 10, 15... pcs	30		45	40	41,5	40	68	136	68	28,5	52,5	194	902381

GP – without tothing, 180° infinitely
GPZ – with tothing, rotation of 180°, 15° intervals

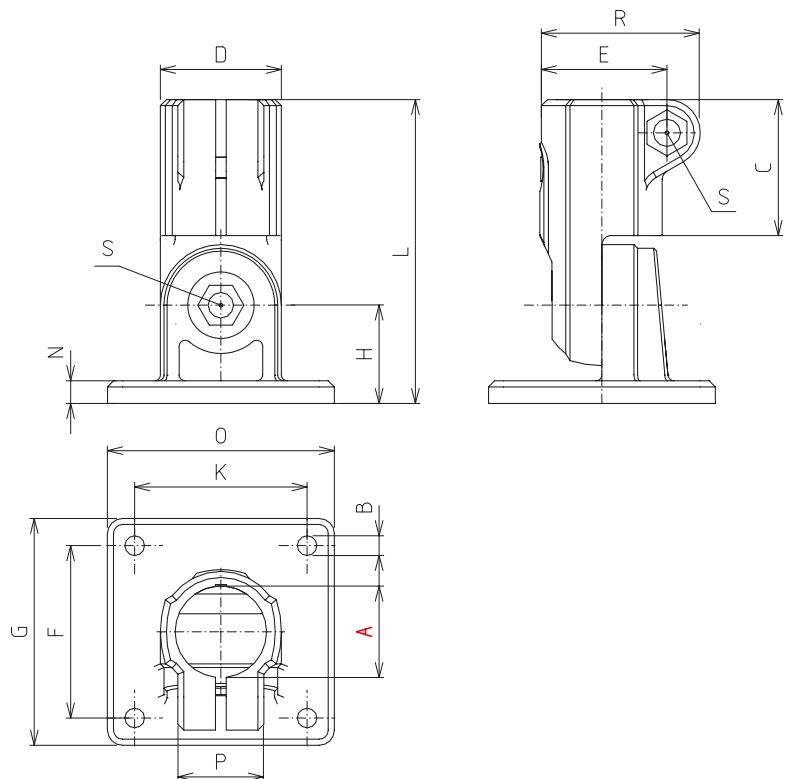
 Anti-twist system
applicable with Type 30

Hinge clamp GF-KU (without tothing) GFZ-KU (with tothing)

Code No.	Type	lot sizes	Clamping* A	B	C	D	E	F	G	H	K*	L	N	O	P	R	[mm]	
																	Weight m [g]	Clamping lever S Code No.
K80218ACSR18	GF 12-18	10, 20, 30... pcs	18	5,3	30	25	26,5	40	50	20	0	65	5	35	21	34	55	93024
K80718ACSR18	GFZ 12-18	10, 20, 30... pcs	18	5,3	30	25	26,5	40	50	20	0	65	5	35	21	34	55	93024
K80230ACSR30	GF 20-30	5, 10, 15... pcs	30	6,5	45	40	41,5	60	75	32,5	60	100,5	7,5	75	28,5	52,5	184	902381
K80730ACSR30	GFZ 20-30	5, 10, 15... pcs	30	6,5	45	40	41,5	60	75	32,5	60	100,5	7,5	75	28,5	52,5	185	902381

GF – without tothing, 180° infinitely
GFZ – with tothing, rotation of 180°, 15° intervals

*Reduction of the diameter or cross section of the clamping with bushes possible (Accessories p. 54).

RK Light Clamps

Ball joints

Version:

- Ball joint

delivery
from stock



Single-piece elements

- For faster and more economic assembly

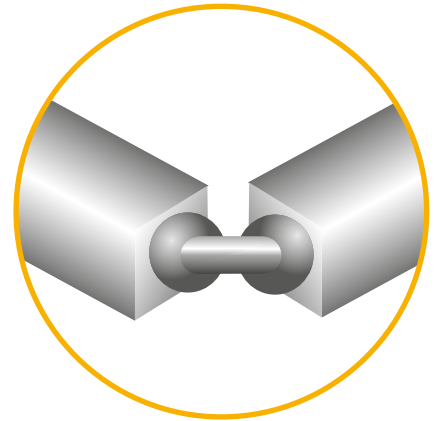

RKLightClamps

- Easy
- Good value
- Variable

Features:

- can be pivoted freely by 60°/can be rotated 360°
- can be combined with tube connectors of sizes 18
- the clamps feature a universal connecting plate for flexible integration
- high-strength clamping thanks to special finishes



Loads

Attention!

The data in the chart do not ensure a guarantee of quality or a warrant characteristic of our products. These are nonbinding standard values which might be not reached in individual cases due to the temperature or surface finish of the clamping profile.

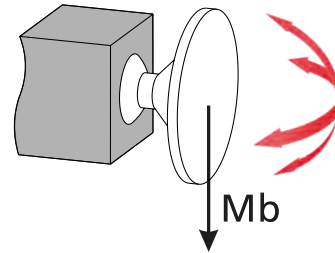

Bending moment Mb [Nm]

Size	18	30
Light Clamps (plastic)		
KGW-KU	8	-
KGFS-2-KU	5	-
KGM-KU	5	-
KGGPZ-KU	8	-

Tightening torque of clamping screws:

M6: 8 Nm
M8: 25 Nm

Material data sheet available upon request.

Overview

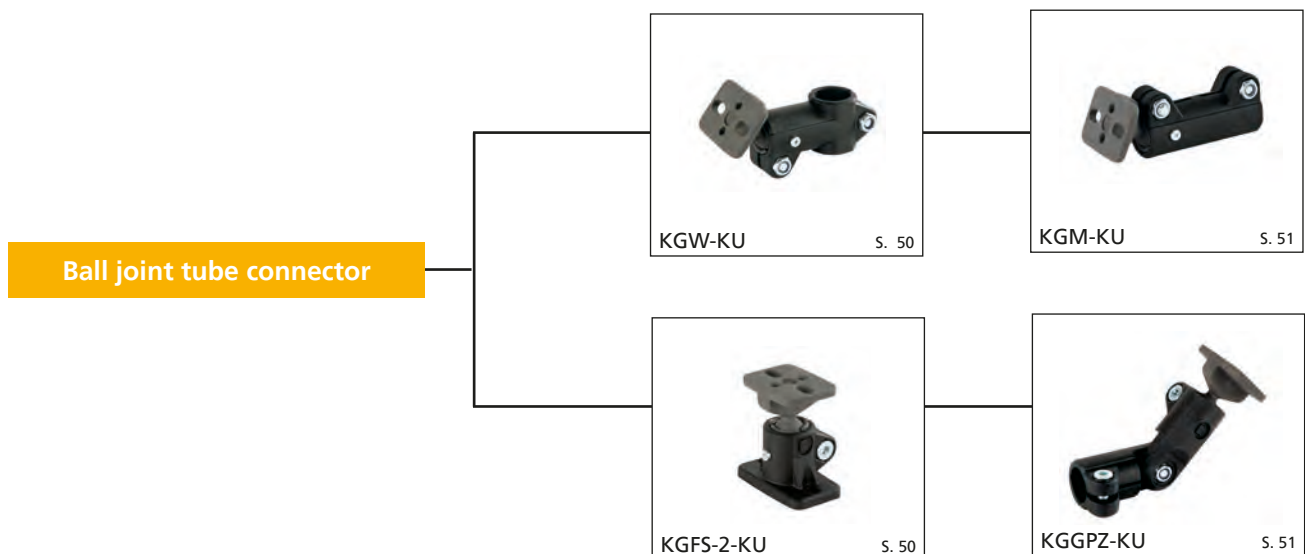

RK Light Clamps

Ball joints

Order instruction:

- Purchase only in lot sizes and a multiple of that, see product table below
- Inserts and bushes for diameter/cross-section changes see accessories page 54
- Standard: equipped and preassembled with galvanised screws
- Clamping levers have to be ordered separately, delivery unassembled
See table last column and page 55

On request:

- Stainless screws

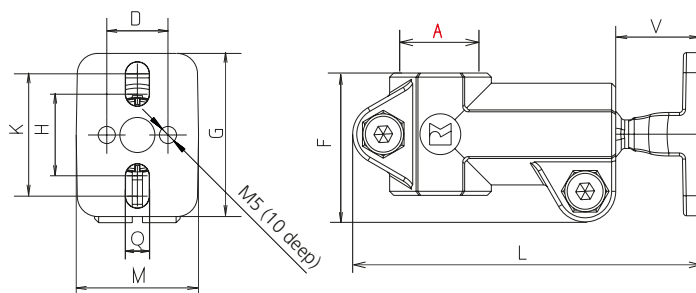

Angle clamp KGW-KU 18

[mm]

Code No.	Type	Clamping A*	D	F	G	H	K	L	M	Q	V	m [g]
K13518ACSR18	KGW-KU 18	18,1	15	30	40	20	30	85	30	5,5	21	63

*Reduction of the diameter or cross section of the clamping with bushes possible (Accessories p. 54).

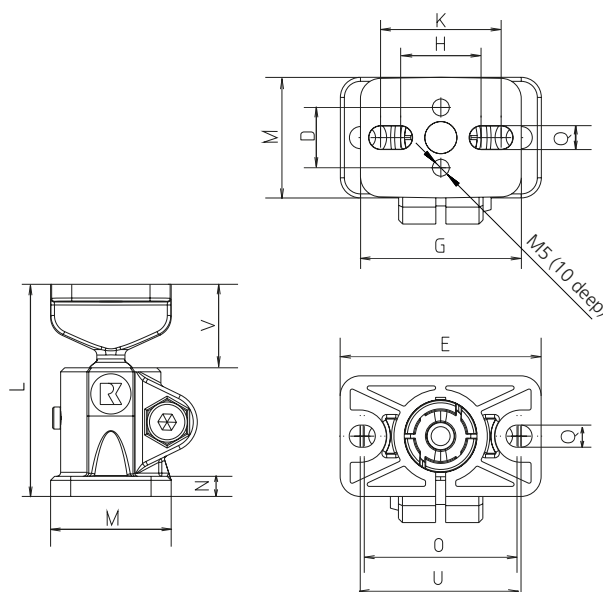

Base clamp KGFS-2-KU 18

[mm]

Code No.	Type	D	E	G	H	K	L	M	N	O	Q	U	V	m [g]
K33518ACS	KGFS-2-KU 18	15	50	40	20	30	53	30	5	38	5,5	40	21	49

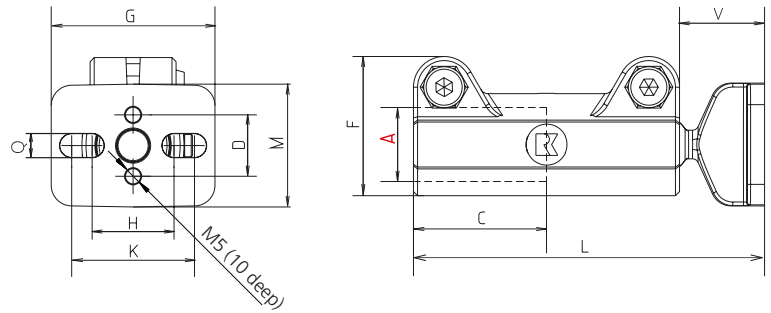

Sleeve clamp KGM-KU 18

[mm]

Code No.	Type	Clamping A*	C	D	F	G	H	K	L	M	V	Q	m [g]
K43518ACSR18	KGM-KU 18	18,1	32,5	15	34	40	20	30	86	30	21	5,5	63

*Reduction of the diameter or cross section of the clamping with bushes possible (Accessories p. 54).

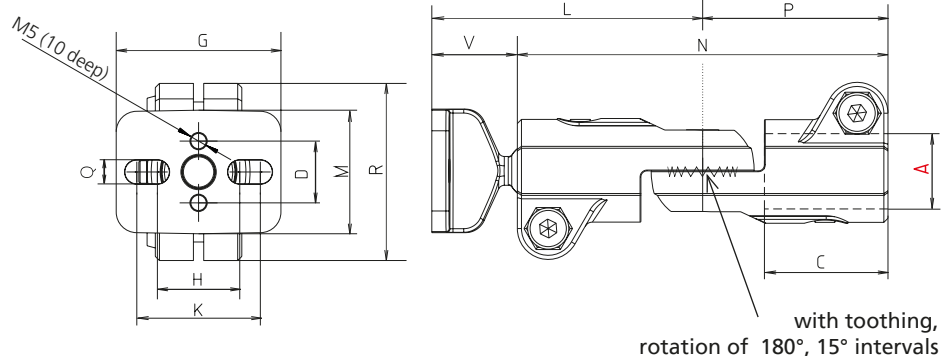

Hinge clamp KGGPZ-KU 18

[mm]

Code No.	Type	Clamping A*	C	D	G	H	K	L	M	N	P	Q	R	V	m [g]
K83518ACSR18	KGGPZ-KU 18	18,1	30	15	40	20	30	66	30	90	45	5,5	43	21	80

*Reduction of the diameter or cross section of the clamping with bushes possible (Accessories p. 54).

RK Light Clamps

Anti-Twist-System



Slot profile

Code. No.	Type
9850002	slot profile 30 mm, standard length 6 m
9850003	slot profile 30 mm, Cut-to-length

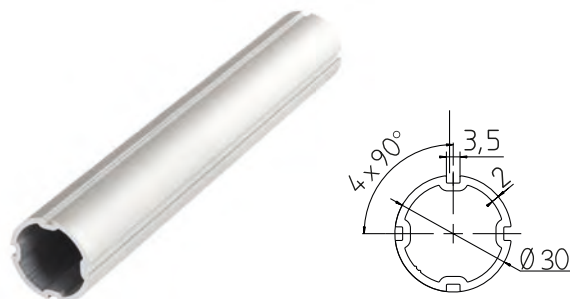

R-Clip

Code. No.	Type	Slot sizes
9850001	R-Clip for slot profile 30 mm	10, 20, 30 ... pcs



RK Light Clamps	Version Ø 30 mm	Catalog page
Cross clamp	K-KU, KVR-KU	page 34, 35
Angle clamp	W-KU	page 36
Base clamp	FS-KU	page 37
Sleeve Clamp	M-KU	page 38
Flanch Clamp	FK-KU	page 39
Strap clamp	LP-KU, LPZ-KU, LW-KU	page 41, 42
Hinge clamp	GW-KU, GP-KU, GF-KU GWZ-KU, GPZ-KU, GF-KU	page 43-45

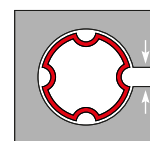

- anti-twist system can be used with one-piece RK Light Clamps (See table)
- See also product information page 31.



Application examples

RK ROSE+KRIEGER

Mechanical engineering / plant engineering / special mechanical engineering



Order picking trolley

Mounting for printer

Medicine / Laboratory / Chemistry / Pharma

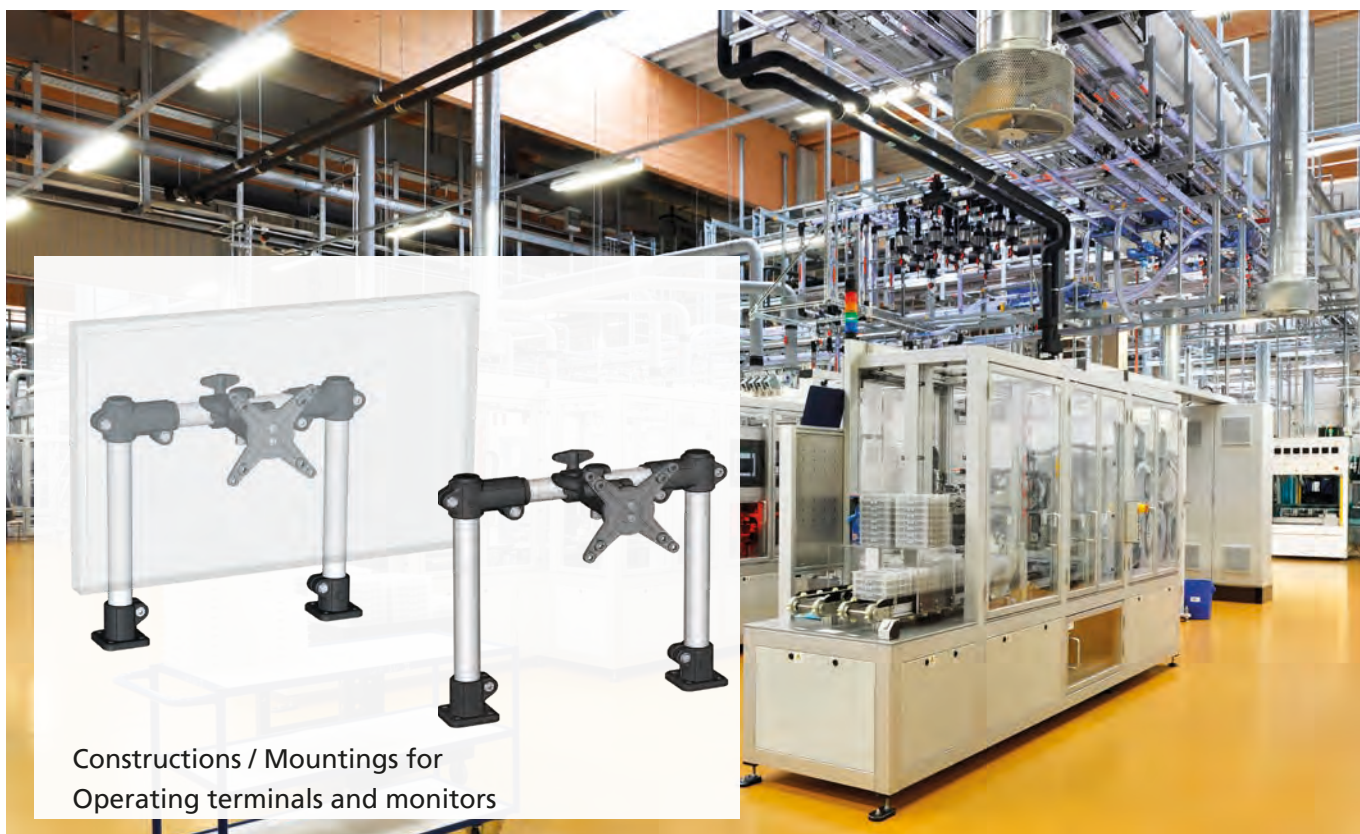

Constructions / Mountings for
Operating terminals and monitors

Introduction

Selection guide

Light Clamps

Solid Clamps

Robust Clamps

EMS

Accessories

ITAS

RK Monitor
Mounting

Appendix

RK Light Clamps

Accessories

Order instruction:

- Purchase only in lot sizes and a multiple of that, see product table below

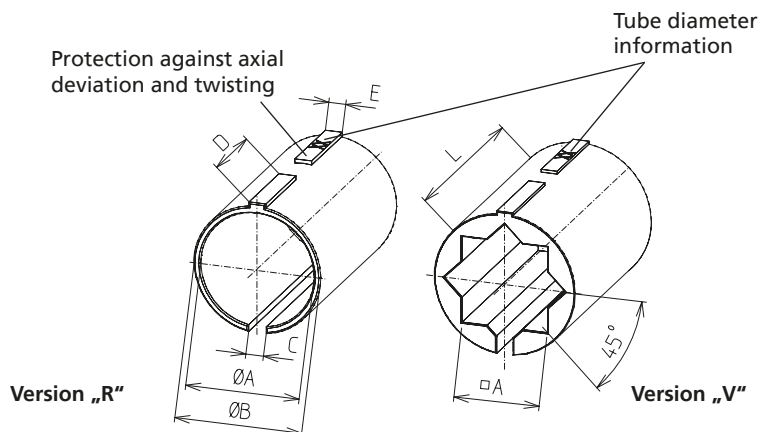

Reducing bushes for single-pcs elements

[mm]

Code No.	Type	Version	lot sizes	A + 0,1	B	C	D	E	L
96200AC	12-18	R12	10, 20, 30... pcs	12,25	18	2,5	11,9	2,4	30
96209AC	12-18	R13	10, 20, 30... pcs	13,25	18	2,5	11,9	2,4	30
96201AC	12-18	R14	10, 20, 30... pcs	14,25	18	2,5	11,9	2,4	30
96202AC	12-18	R15	10, 20, 30... pcs	15,25	18	2,5	11,9	2,4	30
96203AC	12-18	R16	10, 20, 30... pcs	16,25	18	2,5	11,9	2,4	30
96205AC	12-18	V10	10, 20, 30... pcs	10,25	18	2,5	11,9	2,4	30
96204AC	20-30	R20	5, 10, 15... pcs	20,25	30	3,5	18,9	3,4	45
96206AC	20-30	R25	5, 10, 15... pcs	25,25	30	3,5	18,9	3,4	45
96208AC	20-30	V20	5, 10, 15... pcs	20,25	30	3,5	18,9	3,4	45

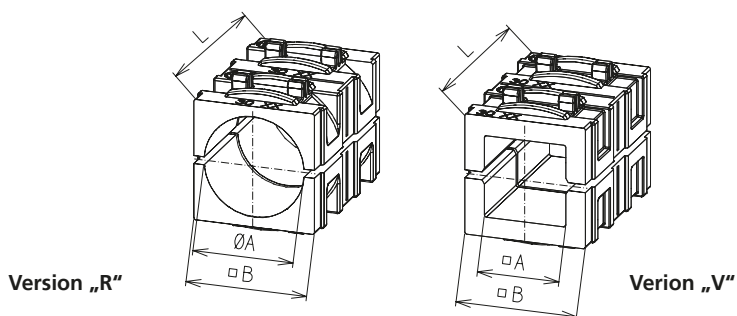

Reducing inserts for multi-pcs elements

[mm]

Code No.	Type	Version	lot sizes	A	B	L
963000AC	20-30	R20	5, 10, 15... pcs	20,25	30,3	45
963002AC	20-30	R25	5, 10, 15... pcs	25,25	30,3	45
963004AC	20-30	R30	5, 10, 15... pcs	30,25	30,3	45
963001AC	20-30	V20	5, 10, 15... pcs	20,50	30,3	45
963003AC	20-30	V25	5, 10, 15... pcs	25,50	30,3	45

Clamping lever



(Symbolic representation)

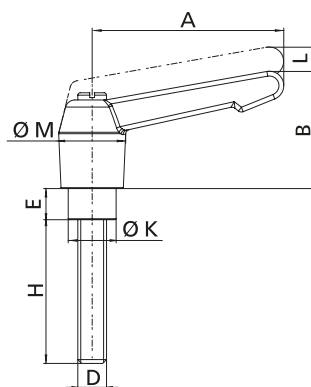

- The clamping lever enables the re-adjustment of the clamping element. This can be done by easy exchange of the cylinder screw.
- By lifting the grip, the free movement of the serration toothing enables the clamping lever to swing into the desired position. The grip moves into its original position when released.

Material: Grip made of polyamide, black, screws made of stainless steel

Stainless steel (single-pcs elements)

[mm]

Code No.	Type	A	B	D	E	H	K	L	M
93024	12-18	40	26	M6	10	18	10	3,5	14,5
902381	20-30	65	35	M8	14	25	13	4	19,5



Screws – Steel, zinc-plated

[mm]

Code No.	Type	lot sizes	Size	Description
40061601	12-18	100, 200, 300... pcs	M6x18 / DIN 7984	Socket head cap screw
40061161			M6 / DIN 985	Hexagonal nut
40061801	20-30	100, 200, 300... pcs	M8x16 / DIN 7984	Socket head cap screw
40061851			M8x25 / DIN 7984	Socket head cap screw
40061181			M8 / DIN 985	Hexagonal nut



Screws – Stainless steel

[mm]

Code No.	Type	lot sizes	Size	Description
40091601	12-18	100, 200, 300... pcs	M6x18 / DIN 7984	Socket head cap screw
40091161			M6 / DIN 985	Hexagonal nut
40091801	20-30	100, 200, 300... pcs	M8x16 / DIN 7984	Socket head cap screw
40091851			M8x25 / DIN 7984	Socket head cap screw
40091181			M8 / DIN 985	Hexagonal nut

Overview - Resistance to chemicals

Medium	resistant	conditionally resistant	not resistant
Acetic acid		◐	
Aqua regia			○
Benzene + Fuel	●		
Benzole	●		
Brake fluid	●		
Butane	●		
Butanol	●		
Butyl acetate	●		
Carbon Tetrachloride	●		
Caustic soda	●		
Chlorofluorocarbon	●		
Chloroform		◐	
Cresol		◐	
Dekalin	●		
Dibutyl phthalate	●		
Diesel	●		
Dimethylformamide		◐	
Diocetyl phthalate	●		
Dioxan	●		
Engine oils	●		
Ethanol		◐	
Fats + Waxes	●		
Fatty acids	●		
Gear oil	●		
Glycol		◐	
Glystantin	●		
Glycerine	●		
Heating oil	●		
Heptane, Hexane	●		
Hydraulic oil	●		
Hydrochloric acid			○
Isopropanol	●		
Isooctane	●		
Methanol		◐	
Methylene chloride			○
Mineral oils		◐	
Naphthalene	●	◐	
Ozone			○
Phenol		◐	
Phosphoric acid		◐	



Medium	resistant	conditionally resistant	not resistant
Potassium hypochloride			○
Sulphuric acid			○
Silicone oil	●		
Styrolene	●		
Tetrahydrofurane	●		
Toluol	●		
Trichlorethylene		◐	
Water	●		
Xylene		◐	

This table is valid for all the clamping elements of the RK Light-Clamps programme.
 The indications in the table are provided without guarantee, being the materials behaviour under real application conditions affected by different factors i.e. temperature, substance concentration, short-term or permanent presence of chemicalp.

Material	Reinforced polyamide
Working temperature	
0°C to 80°C	always
-30°C to 120°C	temporary



Solid Clamps

Medium to heavy load range

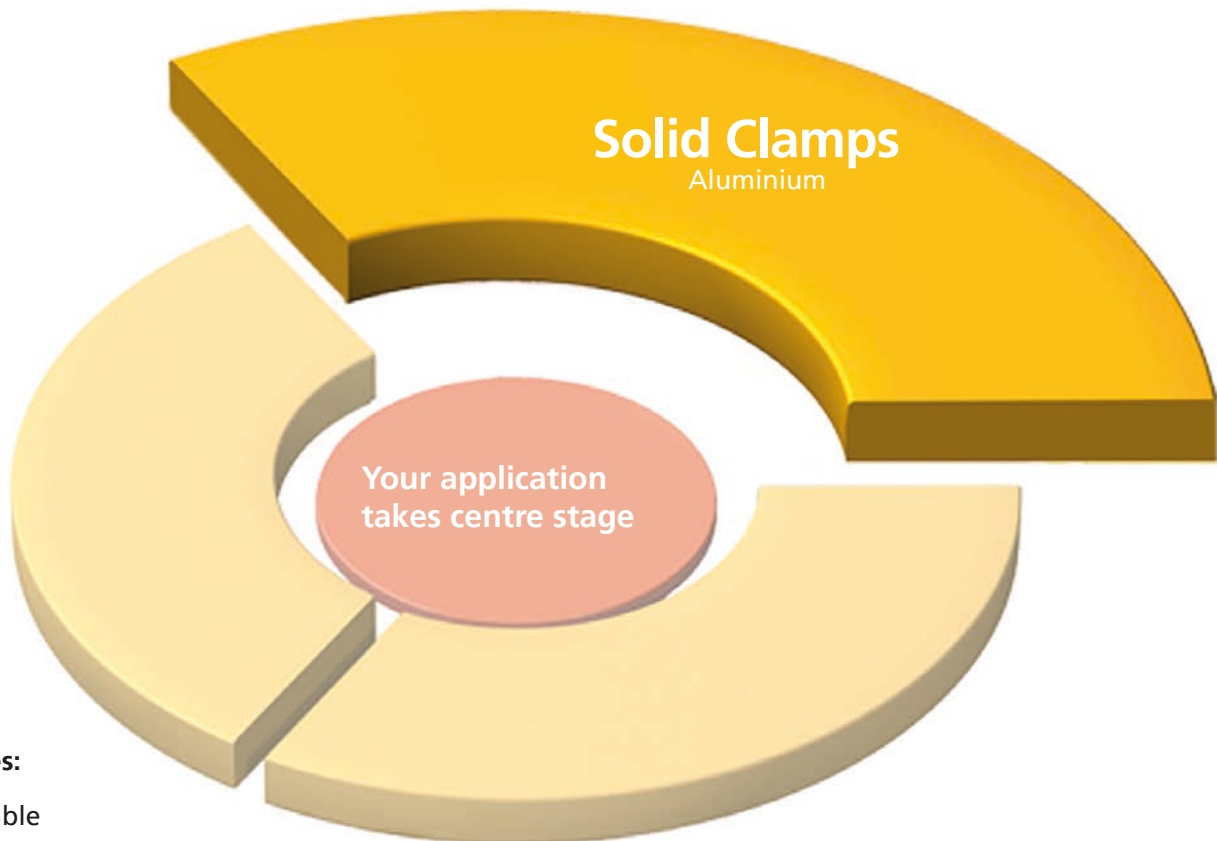
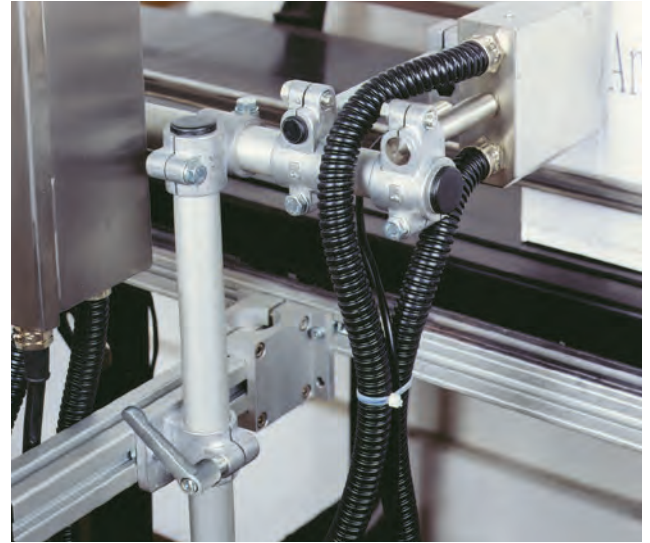

Features:

- Reliable
- Solid
- Price/Performance optimised
- Great variety

...the precise connecting technology made of aluminium

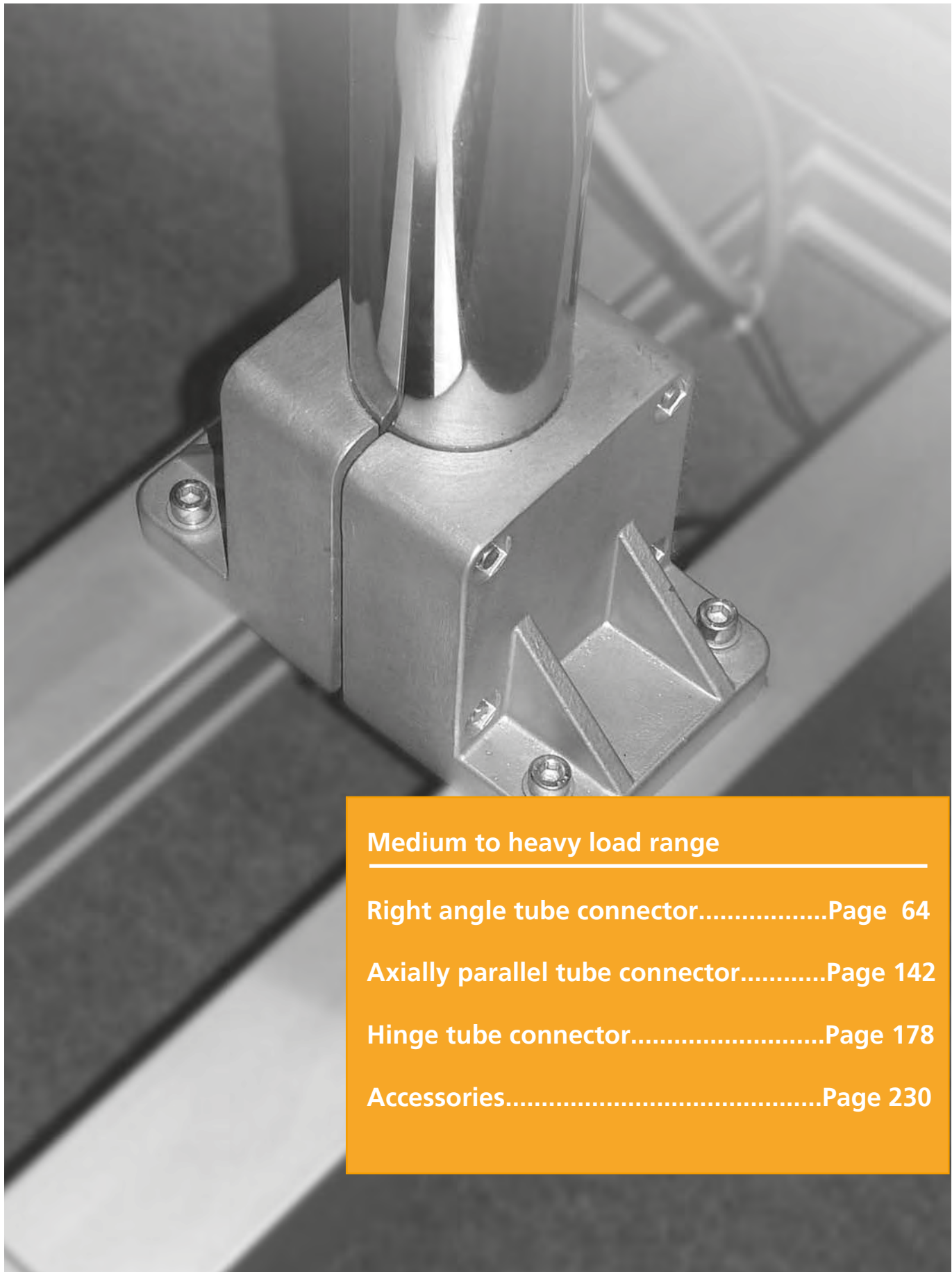

Medium to heavy load range

Right angle tube connector.....Page 64

Axially parallel tube connector.....Page 142

Hinge tube connector.....Page 178

Accessories.....Page 230

Solid Clamps

Medium to heavy load range

...the precise connecting technology made of aluminium

- Right angle tube connector

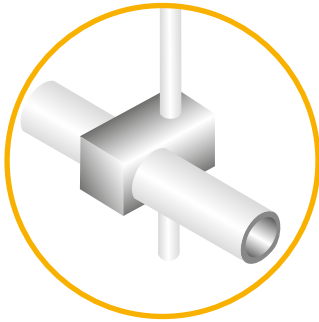

Cross clamps

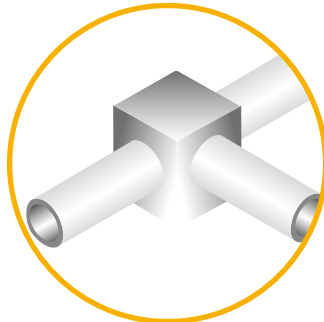

Angle clamps

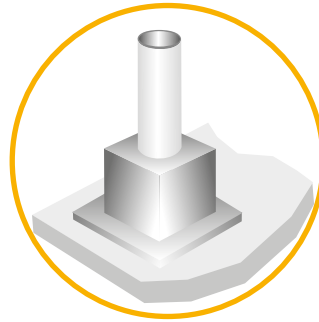

Base clamps

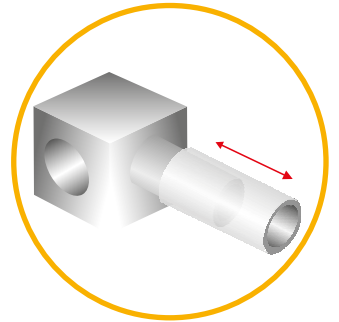

Insert clamps

- Axially parallel tube connector

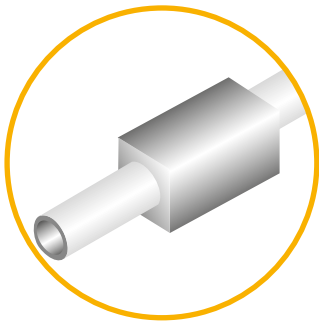

Sleeve clamps

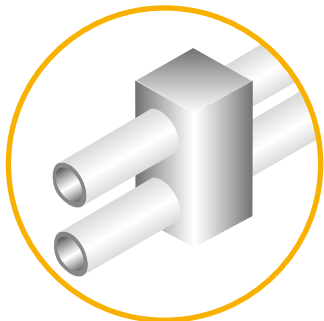

Parallel clamps

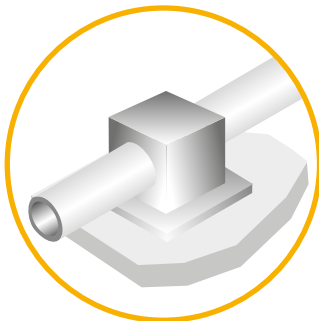

Flange clamps

- Hinge tube connector

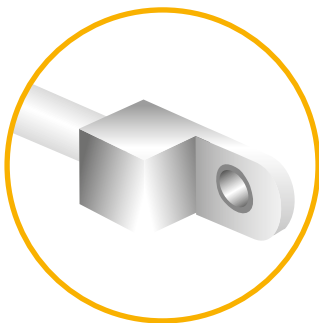

Strap clamps

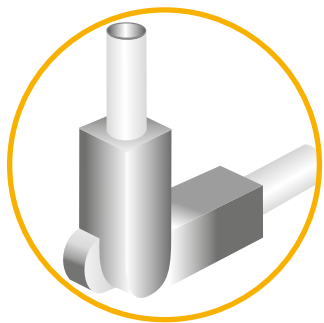

Hinge clamps

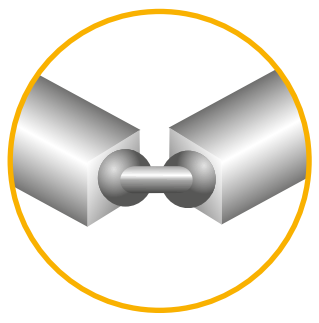

Ball joint clamps

Solid Clamps - table of contents

Right angle tube connector (Single-piece and multi-piece elements)

Cross clamps	p. 62
Angle Clamps	p. 78
Base clamps	p. 100
Insert clamps	p. 122

Axially parallel tube connector (Single-piece and multi-piece elements)

Sleeve clamps	p. 130
Parallel clamps	p. 140
Flange clamps	p. 146

Hinge tube connector (Single-piece and multi-piece elements)

Strap clamps	p. 164
Hinge clamps	p. 176
Ball joint clamps	p. 198

Accessories

Accessories total	p. 230
-------------------------	--------

Solid Clamps

Cross clamps

Version:

- Cross clamps

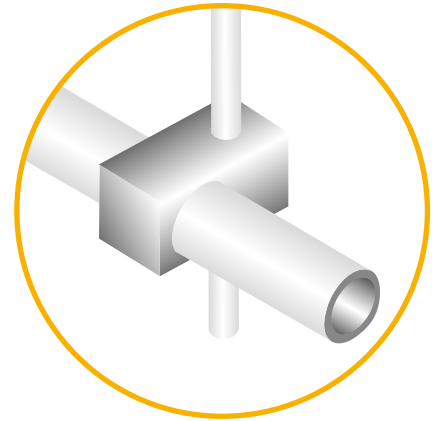

Single-piece elements

- For the quick and inexpensive installation



Industrial design

- Cast aluminium
- Great variety
- Single-piece elements



quad® elements

- Extruded aluminium
- Maximum torque loads
- High-quality anodized surface
- Single- and Multi-piece elements



Multi-piece elements

- Also suitable for subsequent assembly and expansion



quad® elements

- Extruded aluminium
- Maximum torque loads
- High-quality anodized surface
- Single- and Multi-piece elements



Block form

- Cast aluminium
- Higher torque loads
- Plain surface
- Multi-piece elements



Loads cross clamps

Attention!

The data in the chart do not ensure a guarantee of quality or a warrant characteristic of our products. These are nonbinding standard values which might be not reached in individual cases due to the temperature or surface finish of the clamping profile.

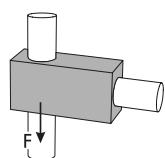

Adhesion force F [KN]

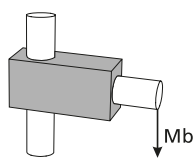

Bending moment Mb [Nm]

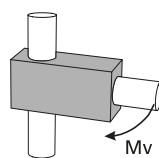

Twisting moment Mv [Nm]

Tightening torque of clamping screws:

M6: 10 Nm
M8: 25 Nm
M10: 50 Nm

Material data sheet available upon request.

Size Type	18			30			40			50			60			80		
	F	Mb	Mv	F	Mb	Mv	F	Mb	Mv	F	Mb	Mv	F	Mb	Mv	F	Mb	Mv
Industrial design																		
K	2,2	126	24	5,8	368	84	4,8	750	43	12,7	1025	368	16	1900	497			
KD				6,9	420	92	9,0	1148	103	2	948	63	16	1900	359			
KR				7,0	396	49	5,5	866	43									
KVR						49	5,0	335	43									
KRR				6,7	713	93	5,5	1131	84									
KV				3,0	393	280	2,8	338	692									
KDVR				6,7	328	249	6,3	198	118									

Size Type	18			30			40			50			60			80		
	F	Mb	Mv	F	Mb	Mv	F	Mb	Mv	F	Mb	Mv	F	Mb	Mv	F	Mb	Mv
Block form																		
KR										9,4	1250	253						
KVR										9,4	1250	253						
KRR				5,1	831	99	5,7	512	114	9,4	1270	254	12,5	1625	261	11	1750	594
KV				2,6	425	429	3,1	512	698	5,9	823	743	7,8	1390	1208	18	1535	2183
KVRR				2,6	831	421	5,7	512	114	13,7	1270	254	7,6	1433	1191	18	1601	2275

Size Type	18			30			40			50			60			80		
	F	Mb	Mv	F	Mb	Mv	F	Mb	Mv	F	Mb	Mv	F	Mb	Mv	F	Mb	Mv
quad® elements																		
K				2	738	51	4,0	960	59	6,9	1250	167						
KD				1	847	61	5,3	1075	62	3,9	1250	59						
KRR				6	1139	50	7,6	1125	121	11,5	1250	272						
KRD				6	1045	41	7,6	1125	121	7,6	1250	121						
KVR				5	854	50	8,1	1001	121	7,5	1750	272						
KV				5	754	303	8,1	804	375	7,5	960	1207						

Cross clamps

Right angle tube connector



Industrial design

Block form

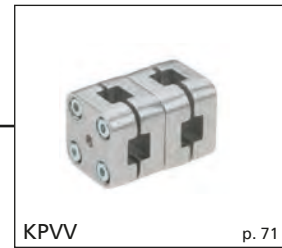

quad® elements

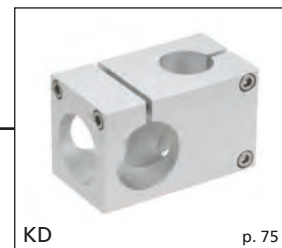
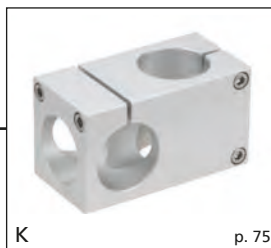

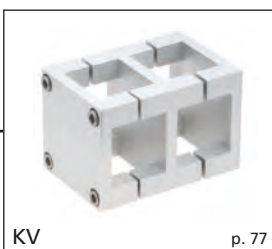
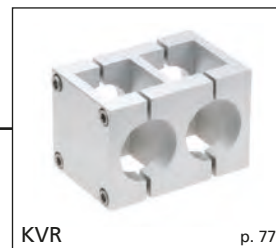
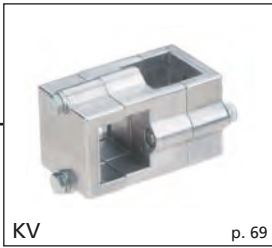
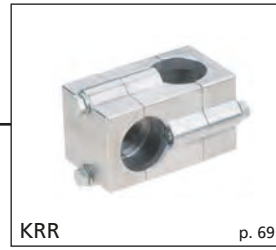

Solid Clamps

Cross clamps

Order instruction:

- Standard equipment premounted zinc plated screws
- Clamping levers have to be ordered separately Delivery unassembled See table last column and page 244

On request:

- Stainless steel screws
- Ball-polished
- Colour

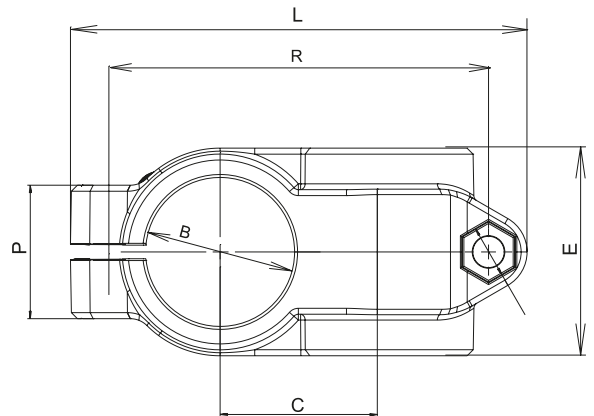
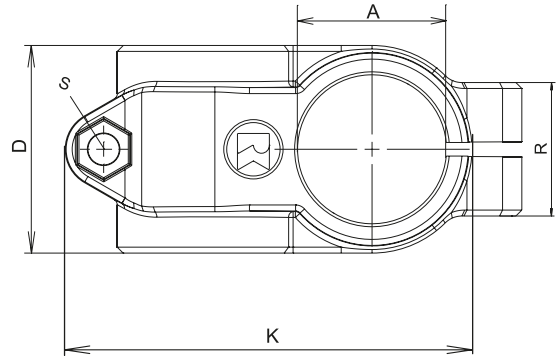

K - Industrial design

[mm]

Code No.	Type	A	B	C	D	E	K	L	P	R	m [g]	Clamping lever S Code No.
101200000200	K 12	12,1	12,1	20	25,5	25,5	43,5	67	23	49	75	90209
101400000200	K 14	14,1	14,1								70	
101500000200	K 15	15,1	15,1								67	
101600000200	K 16	16,1	16,1								64	
101800000200	K 18	18,1	18,1								57	
102000000200	K 20	20,1	20,1	33	40	40	73	101	33	78	252	9022201
102500000200	K 25	25,1	25,1								217	
	K 28*	*With adapter sleeve R28, see accessories page 245										
103000000200	K 30	30,1	30,1	33	40	40	73	101	33	78	173	9022201
103020000200	K 30x20		20,1								195	
103025000200	K 30x25		25,1								195	
103002000200	K 30x32	30,1	30,1	45	60	60	100	137	40	111	665	90250
103200000200	K 32	32,17	32,17								665	
103500000200	K 35	35,17	35,17								617	
104000000200	K 40	40,17	40,17	53	70	70	118	154	45	128	527	90251
104200000200	K 42	42,22	42,22								907	
104800000200	K 48	48,22	48,22								755	
105000000200	K 50	50,2	50,2								699	
105040000200	K 50/40	50,22	40,17								827	
106000000200	K 60	60,27	60,25	65	80	80	142,5	190	58	158	1101	9025301
108000000200	K 80	80,35	80,35	90	120	120	200	255	82	210	3870	9027001

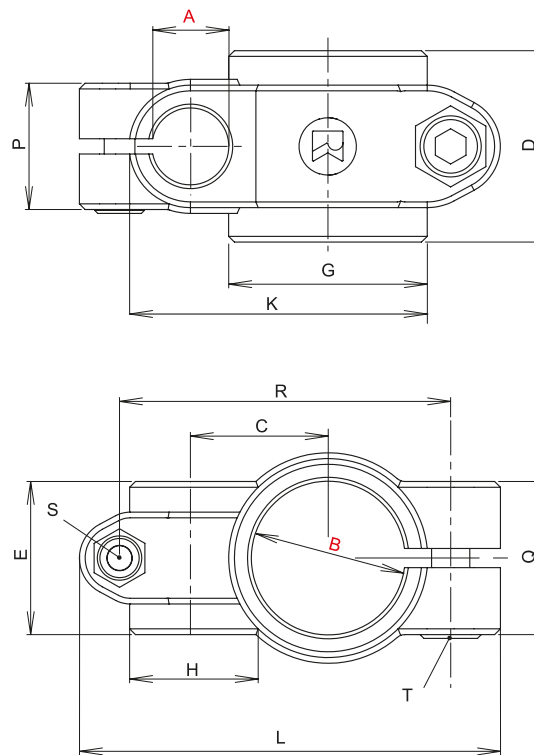

KD - Industrial design

[mm]

Code No.	Type	A	B	C	D	E	G	H	K	L	P	Q	R	m [g]	Clamping lever Code No.	
															S	T
102012010200	KD 20x12	12,1	20,1	27	40	33	40	26	59	84	21	33	65	175	90209	9022201
102014010200	KD 20x14	14,1												172		
102015010200	KD 20x15	15,1												170		
102016010200	KD 20x16	16,1												168		
102018010200	KD 20x18	18,1												163		
102512010200	KD 25x12	12,1	25,1	27	40	33	40	26	59	84	21	33	65	154	90209	9022201
102514010200	KD 25x14	14,1												154		
102515010200	KD 25x15	15,1												152		
102516010200	KD 25x16	16,1												150		
102518010200	KD 25x18	18,1												146		
	KD 28x18*	With adapter sleeve R28, see accessories page 245														
103012010200	KD 30x12	12,1	30,1	27	40	33	40	26	59	84	21	33	65	135	90209	9022201
103014010200	KD 30x14	14,1												132		
103015010200	KD 30x15	15,1												130		
103016010200	KD 30x16	16,1												128		
103018010200	KD 30x18	18,1												124		
103220010200	KD 32x20	20	32,2	36	50	40	52	32	78	110	33	40	86,5	283	9022201	90250
103520010200	KD 35x20	35,2	78						98	28	43	80	257			
104020010200	KD 40x20	20,1	40,17						60	110	33	40	86,5	250		
104030010200	KD 40(42)x30	30,1	40,17	45	65	65	65	45	60	137,5	44	44	108,5	659	90251	90251
104230010200	KD 42x30	30,1	42,2	45	65	65	66	48	102	126	43	58	102	640	90251	90251
105025010200	KD 50x25	25,1	50,22	45	65	49	65	45	60	137,5	44	44	108,5	576	90251	90251
105030010200	KD 50x30	30,1												564		
106040010200	KD 60x40	40,22	60,27	60	80	70	75	65	130	180	58	53	148	1163	9025501	9025301
106050010200	KD 60x50	50,27									53	58		1027		
106250010200	KD 62x50															

Solid Clamps

Cross clamps

Order instruction:

- Standard equipment premounted zinc plated screws
- Clamping levers have to be ordered separately.
Delivery unassembled See table last column and page 244

On request:

- Stainless steel screws
- Ball-polished
- Colour

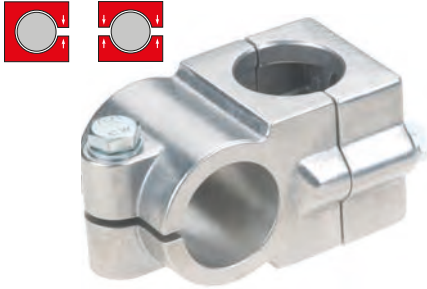
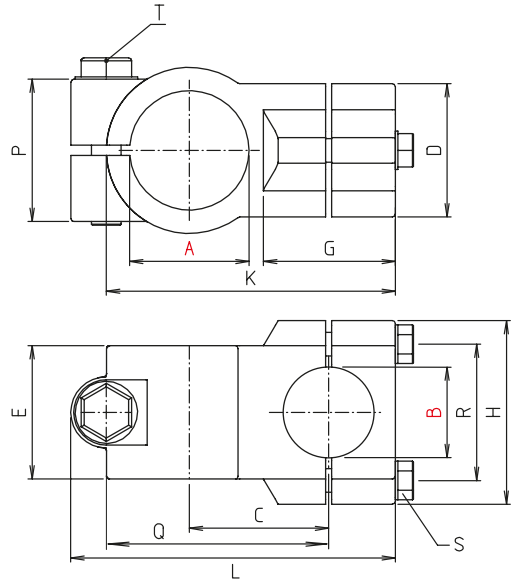

KR - Industrial design

Code No.	Type	A	B	C	D	E	G	H	K	L	P	Q	R	m [g]	[mm]	
															S	T
															Clamping lever Code No.	
102000020200	KR 20	20,1	20,1	33	45	45	40	62	76	86	33	55	46	338	9022401	9022401
102500020200	KR 25	25,1	25,1													
	KR 28*		30,1	*With adapter sleeve R28, see accessories page 245												
103000020200	KR 30	30,1	30,1	33	45	45	40	62	76	86	33	55	46	257	9022401	9022401
103500020200	KR 35	35,2	35,2	47	60	60	60	75	105	117	48	75	57	622	9022501	9024301
104000020200	KR 40	40,2	40,2											557		

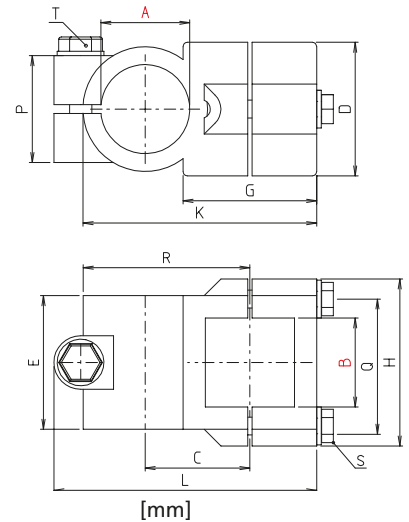

KVR - Industrial design

Code No.	Type	A	B	C	D	E	G	H	K	L	P	Q	R	m [g]	[mm]	
															S	T
															Clamping lever Code No.	
102000040200	KVR 20	20,1	20,2	33	45	45	40	62	76	86	33	46	55	332	9022401	9022401
102500040200	KVR 25	25,1	25,2													
	KVR 28*		30,2	*With adapter sleeve R28, see accessories page 245												
103000040200	KVR 30	30,1	30,2	33	45	45	40	62	76	86	33	46	55	245	9022401	9022401
103500040200	KVR 35	35,2	35,3	47	60	60	60	75	105	117	48	57	75	599	9022501	9024301
104000040200	KVR 40	40,2	40,3											525		

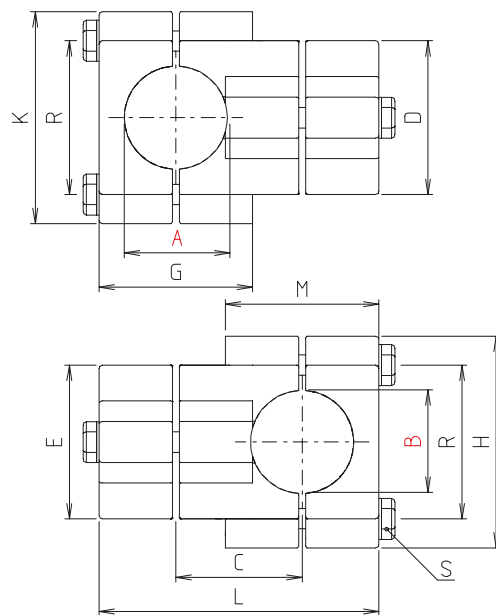

KRR - Industrial design

Code No.	Type	A	B	C	D	E	G	H	K	L	M	R	m [g]	Clamping lever S Code No.
102500030200	KRR 25	25,2	25,2	38	45	45	45	64	64	83	45	46	369	9022501
103000030200	KRR 30	30,2	30,2										352	
103500030200	KRR 35	35,2	35,2	50	60	60	61	77	77	111	61	57	668	9022801
104000030200	KRR 40	40,2	40,2										645	

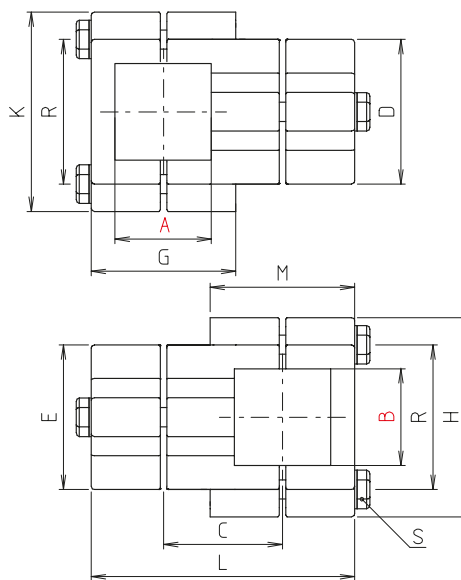

KV - Industrial design

Code No.	Type	A	B	C	D	E	G	H	K	L	M	R	m [g]	Clamping lever S Code No.
102000050200	KV 20	20,3	20,3	38	45	45	44	64	64	83	44	46	385	9022601
102500050200	KV 25	25,2	25,2										353	9022501
103000050200	KV 30	30,2	30,2	50	60	60	61	77	77	111	61	57	637	9022801
103500050200	KV 35	35,3	35,3										584	
104000050200	KV 40	40,3	40,3											

Solid Clamps

Cross clamps

Order instruction:

- Standard equipment premounted zinc plated screws
- Clamping levers have to be ordered separately Delivery unassembled See table last column and page 244

On request:

- Stainless steel screws
- Ball-polished
- Colour

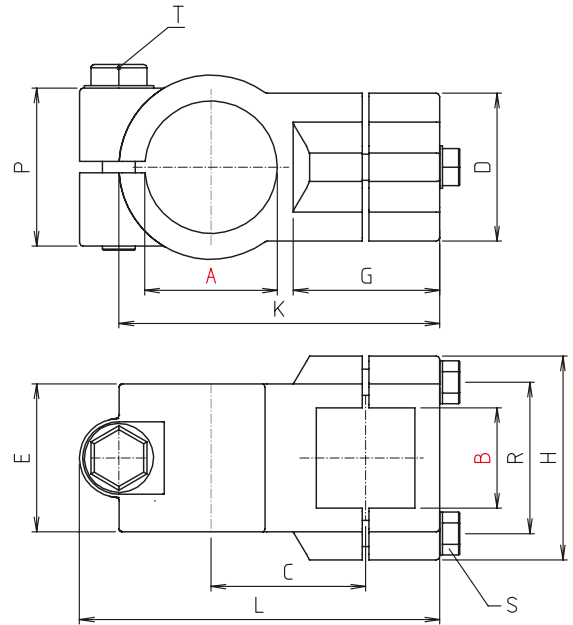
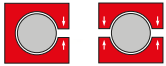

KDVR - Industrial design

[mm]

Code No.	Type	A	B	C	D	E	G	H	K	L	P	R	m [g]	Clamping lever Code No.	
														S	T
104020090200	KDVR 20-40	40,3	20,2	47	45	45	45	62	98	110	48	46	408	9022401	9024301
104025090200	KDVR 25-40		25,2												
104030090200	KDVR 30-40		30,2												

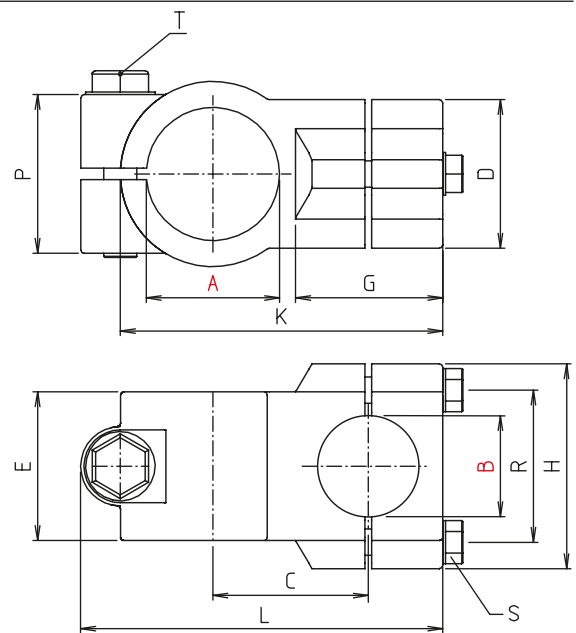
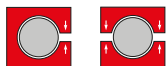

KDRR - Industrial design

[mm]

Code No.	Type	A	B	C	D	E	G	H	K	L	P	R	m [g]	Clamping lever Code No.	
														S	T
102040110200	KDRR 20-40	40,3	20	47	45	45	45	62	98	110	48	46	452	9022401	9024301
102540110200	KDRR 25-40		25,1												

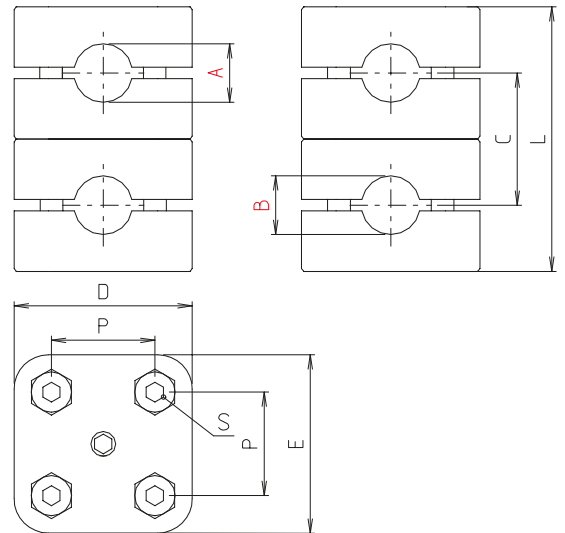

KPRR - Block form

[mm]

Code No.	Type	A	B	C	D	E	L	P	S	m [g]
290800000266	KPRR 8	8	8	23	31	31	46	18	M4x18	97
291000000266	KPRR 10	10	10							93

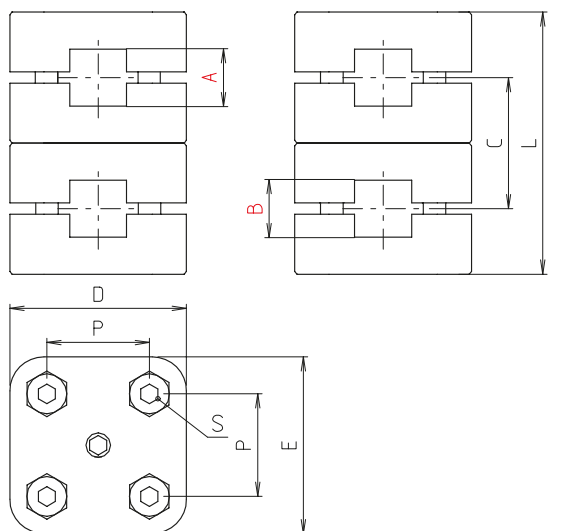

KPVV - Block form

[mm]

Code No.	Type	A	B	C	D	E	L	P	S	m [g]
291000010266	KPVV 10	10	10	23	31	31	46	18	M4x18	88

Solid Clamps

Cross clamps

Order instruction:

- Standard equipment premounted zinc plated screws
- Clamping levers have to be ordered separately Delivery unassembled See table last column and page 244

On request:

- Stainless steel screws
- Ball-polished
- Colour

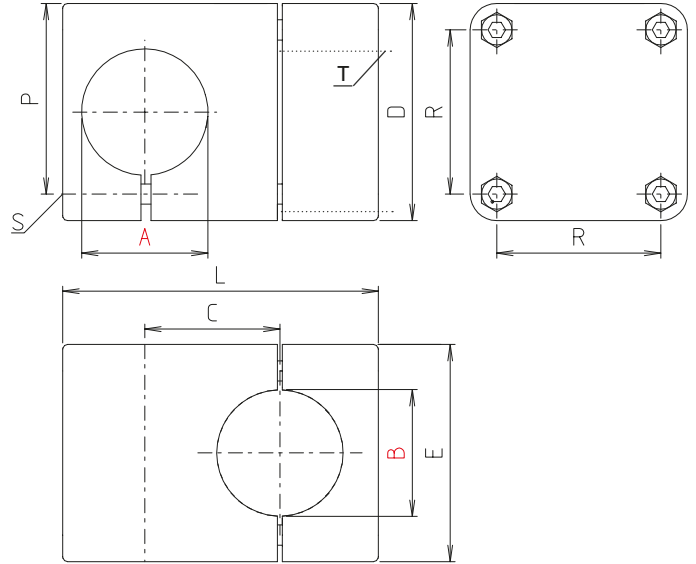
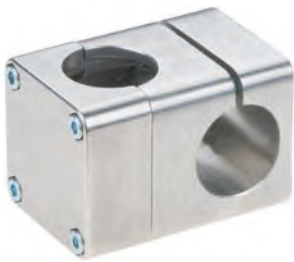
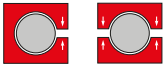

KR - Block form

Code No.	Type	A	B	C	D	E	L	P	R	m [g]	[mm]		
											S	T	
												Clamping lever Code No.	
204200020266	KR 42	42,2	42,2	53	86	86	126	73	65	1367	9022601	9022701	
204500020266	KR 45	45,2	45,2							1310			
204800020266	KR 48	48,2	48,2							1264			
205000020266	KR 50	50,2	50,2							1213			

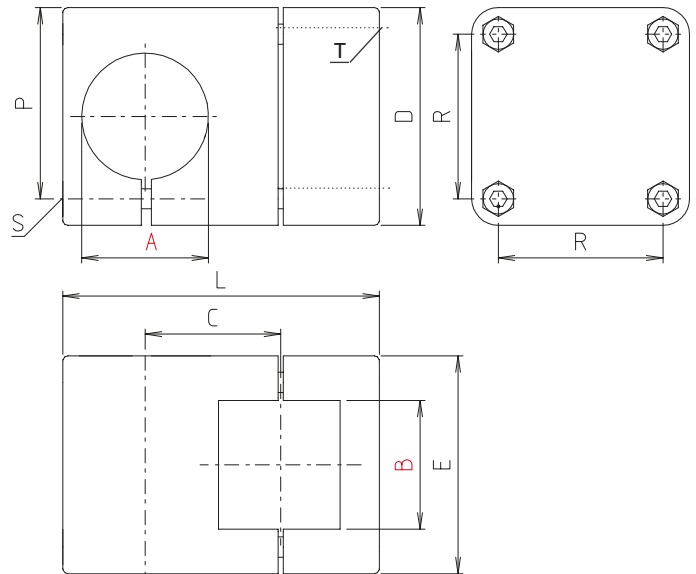
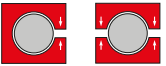

KVR - Block form

Code No.	Type	A	B	C	D	E	L	P	R	m [g]	[mm]		
											S	T	
												Clamping lever Code No.	
204850040266	KVR 48/50	48,2	50,5	53	86	86	126	73	65	1199	9022601	9022701	
205000040266	KVR 50	50,2								1182			



KRR - Block form

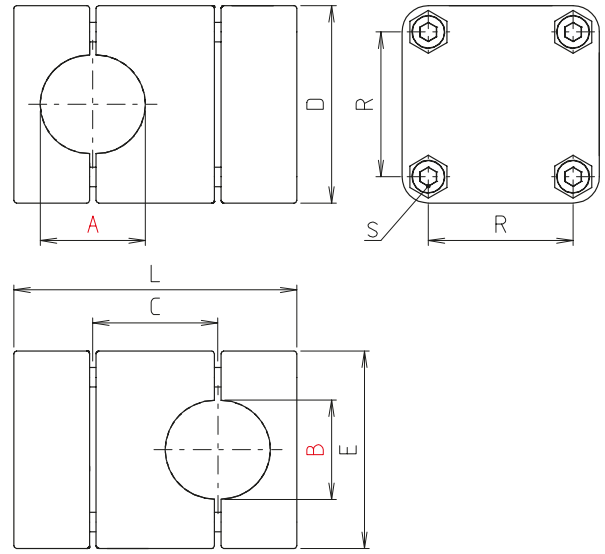

[mm]

Code No.	Type	A	B	C	D	E	L	R	m [g]	Clamping lever S Code No.
203000030266	KRR 30	30,2	30,2	38	60	60	86	44	450	9021301
204000030266	KRR 40	40,3	40,3	50	70	70	112	53	688	9021501
204200030266	KRR 42	42,3	42,3	70	86	86	149	65	1614	9022801
204500030266	KRR 45	45,3	45,3						1579	
204800030266	KRR 48	48,3	48,3						1550	
205000030266	KRR 50	50,3	50,3						1520	
206000030266	KRR 60	60,4	60,4	80	100	100	170	78	2048	
208000030266	KRR 80	80,5	80,5	122	130	130	244	100	5075	9024601

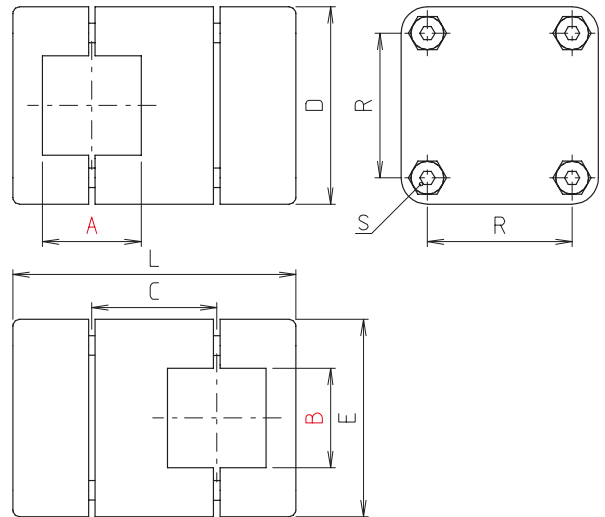

[mm]

KV - Block form

Code No.	Type	A	B	C	D	E	L	R	m [g]	Clamping lever S Code No.
203000050266	KV 30	30,2	30,2	38	60	60	86	44	329	9021301
204000050266	KV 40	40,4	40,4	50	70	70	112	53	661	9021501
205000050266	KV 50	50,5	50,5	70	86	86	149	65	1427	9022801
206000050266	KV 60	60,6	60,6	80	100	100	170	78	1950	
208000050266	KV 80	80,7	80,7	122	130	130	244	100	4850	9024601

Solid Clamps

Cross clamps

Order instruction:

- Block form zinc plated screws Quad® with stainless steel screws
- Clamping levers have to be ordered separately Delivery unassembled See table last column and page 244

On request:

- Stainless steel screws
- Ball-polished
- Colour

On request quad®:

- Black anodized

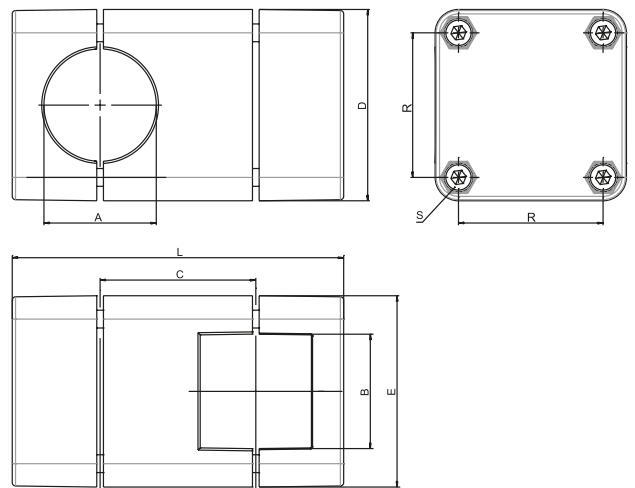

KVRR - Block form

[mm]

Code No.	Type	A	B	C	D	E	L	R	m [g]	Clamping lever S Code No.
203000080266	KVRR 30	30,2	30,2	38	60	60	86	44	441	9021301
204000080266	KVRR 40	40,4	40,3	50	70	70	112	53	671	9021501
205000080266	KVRR 50	50,5	50,3	70	86	86	149	65	1477	9022801
206000080266	KVRR 60	60,6	60,4	80	100	100	170	78	1987	9022801
208000080266	KVRR 80	80,7	80,5	122	130	130	244	100	5075	9024601

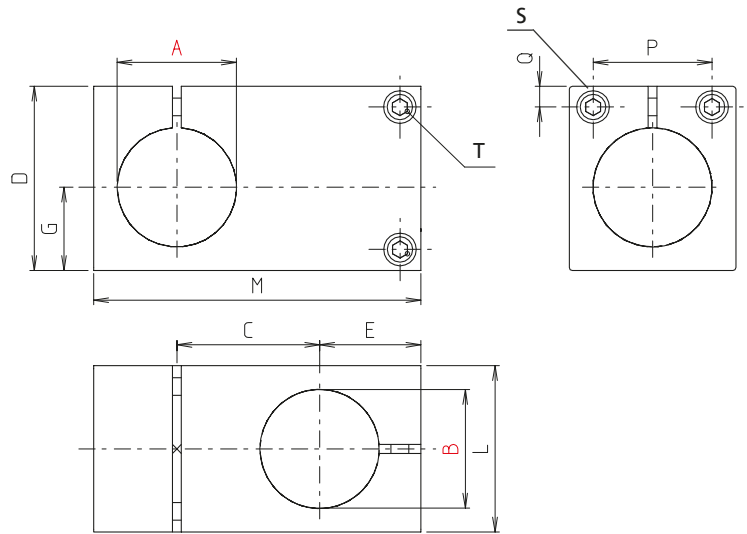

K - quad®

[mm]

Code No.	Type	A	B	C	D	E	G	L	M	P	Q	m [g]	S	T
													Clamping lever Code No.	
503000000300	K 30	30,1	30,1	36	49	28	21	42	85	28	7	236	9301401	9300101
504000000300	K 40	40,1	40,1	48	62	34	28	56	110	42	7	490	9301701	9301401

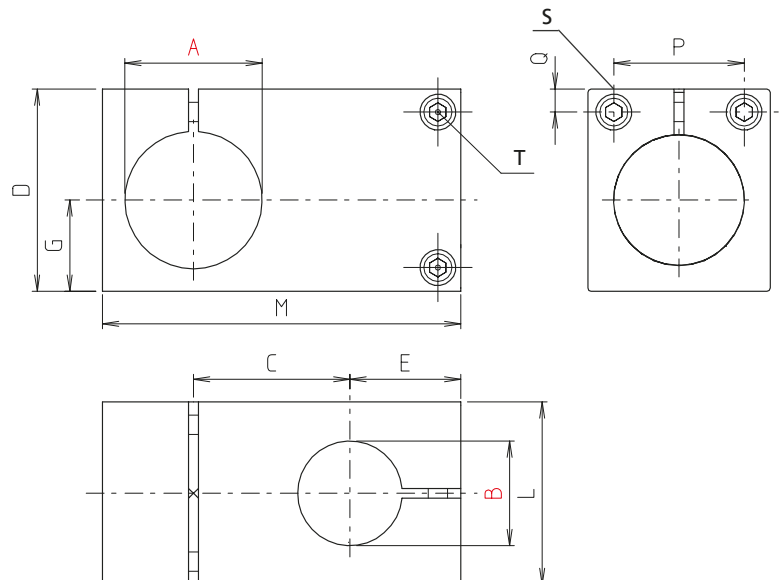

KD - quad®

[mm]

Code No.	Type	A	B	C	D	E	G	L	M	P	Q	m [g]	S	T
													Clamping lever Code No.	
503020010300	KD 30x20	30,1	20,1	31	49	23	21	42	75	28	7	229	9301401	9300101
504030010300	KD 40x30	40,1	30,1	43	62	29	28	56	100	42	7	477	9301701	9301401
505040010300	KD 50x40	50,2	40,2	55	77	37	35	70	127	52	9	926	9300401	9300401

Solid Clamps

Cross clamps

Order instruction:

- Block form zinc plated screws Quad® with stainless steel screws
- Clamping levers have to be ordered separately Delivery unassembled. See table last column and page 244

On request:

- Stainless steel screws
- Ball-polished
- Colour

On request quad®:

- Black anodized

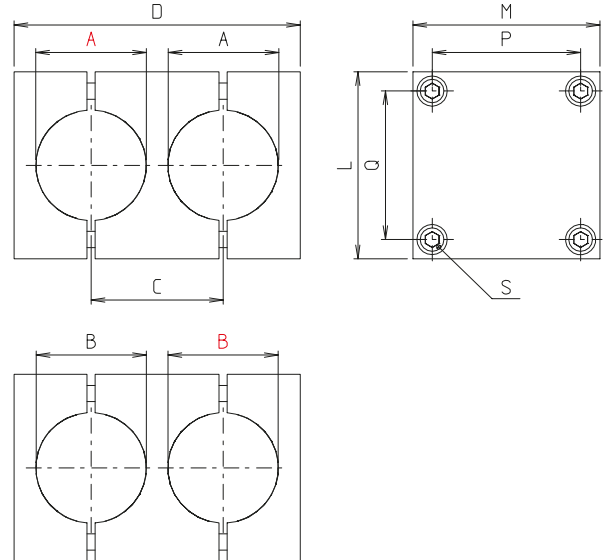

KRR - quad®

[mm]

Code No.	Type	A	B	C	D	L	M	P	Q	m [g]	Clamping lever S Code No.
504000030300	KRR 40	40,2	40,2	48	104	68	68	54	54	615	9301401
505000030300	KRR 50	50,3	50,3	60	130	85	85	67	67	1241	9300401
506000030300	KRR 60	60,3	60,3	72	169	105	105	85	85	-	9022801

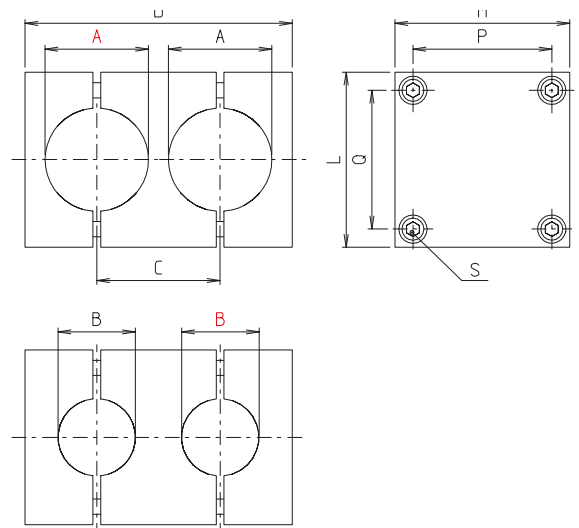

KRD - quad®

[mm]

Code No.	Type	A	B	C	D	L	M	P	Q	m [g]	Clamping lever S Code No.
504030060300	KRD 40x30	40,2	30,1	48	104	68	68	54	54	723	9301401
505040060300	KRD 50x40	50,3	40,2	60	130	85	85	67	67	1411	9300401
506050060300	KRD 60x50	60,3	50,4	72	169	105	105	85	85	-	9022801

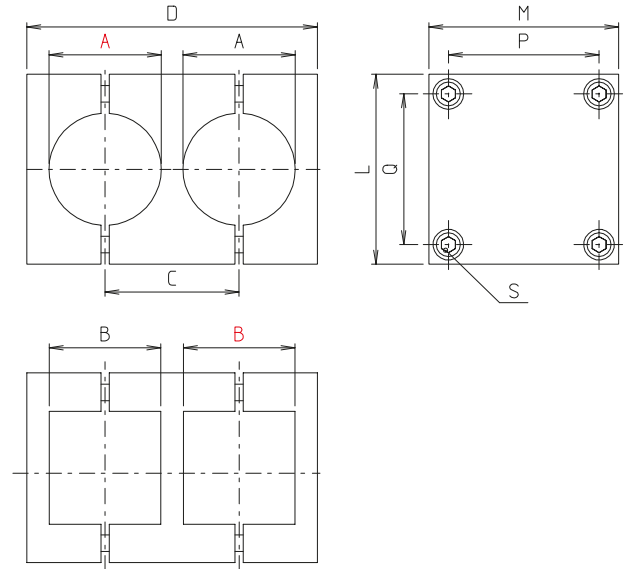

KVR - quad®

[mm]

Code No.	Type	A	B	C	D	L	M	P	Q	m [g]	Clamping lever S Code No.
504000040300	KVR 40	40,2	40,3	48	104	68	68	54	54	527	9301401
505000040300	KVR 50	50,3	50,4	60	130	85	85	67	67	1080	9300401
506000040300	KVR 60	60,3	60,4	72	169	105	105	85	85	-	9022801

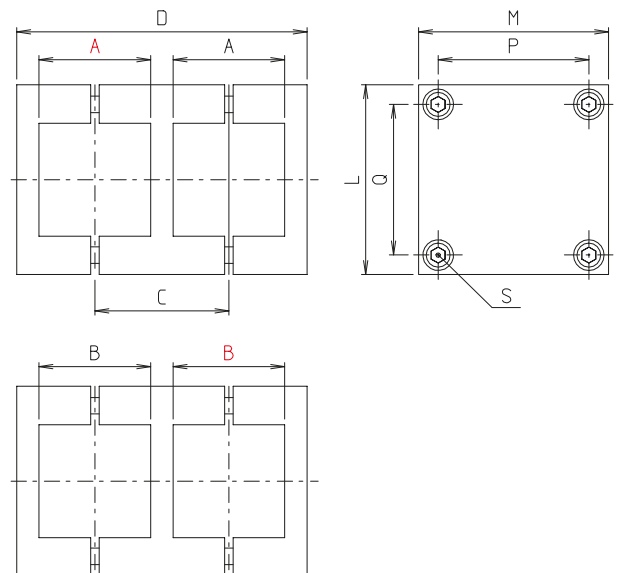

KV - quad®

[mm]

Code No.	Type	A	B	C	D	L	M	P	Q	m [g]	Clamping lever S Code No.
503000050300	KV 30	30,2	30,2	36	78	56	56	42	42	277	9300101
504000050300	KV 40	40,3	40,3	48	104	68	68	54	54	477	9301401
505000050300	KV 50	50,4	50,4	60	130	85	85	67	67	961	9300401
506000050300	KV 60	60,4	60,4	72	169	105	105	85	85	-	9022801

Solid Clamps

Angle clamps

Version:

- Angle clamps

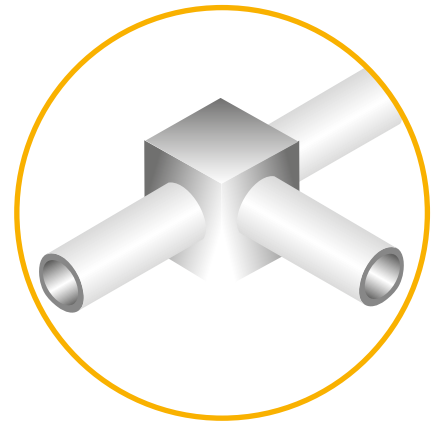

Single-piece elements

- For the quick and inexpensive installation



Industrial design

- Cast aluminium
- Great variety
- Single-piece elements



quad® elements

- Extruded aluminium
- Maximum torque loads
- High-quality anodized surface
- Single- and Multi-piece elements



Multi-piece elements

- Also suitable for subsequent assembly and expansion



quad® elements

- Extruded aluminium
- Maximum torque loads
- High-quality anodized surface
- Single- and Multi-piece elements



Block form

- Cast aluminium
- Higher torque loads
- Plain surface
- Multi-piece elements

Loads angle clamps

Attention!

The data in the chart do not ensure a guarantee of quality or a warrant characteristic of our products. These are nonbinding standard values which might be not reached in individual cases due to the temperature or surface finish of the clamping profile.

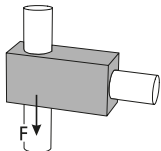

Adhesion force F [KN]

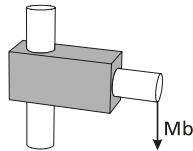

Bending moment Mb [Nm]

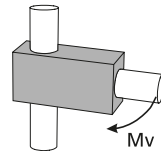

Twisting moment Mv [Nm]

Tightening torque of clamping screws:

M6: 10 Nm
M8: 25 Nm
M10: 50 Nm

Material data sheet available upon request.

Size Type	18			30			40			50			60			80		
	F	Mb	Mv	F	Mb	Mv	F	Mb	Mv	F	Mb	Mv	F	Mb	Mv	F	Mb	Mv
Industrial design																		
W	1,1	189	20	6,6	447	104	4,3	1365	104	12,1	900	217	10,7	1388	299			
WV				3,3	413	345	4,3	464	546									
WR				5,1	870	59	5,1	1174	158									
WE				6,6	494	41	6,6	300	300	10,6	409	217						
WVT				3,3	144	345	2,6	765	546									
WRT				5,1	141	63	5,1	1174	120									

Size Type	18			30			40			50			60			80		
	F	Mb	Mv	F	Mb	Mv	F	Mb	Mv	F	Mb	Mv	F	Mb	Mv	F	Mb	Mv
Block form																		
WV				3,6	383	283	3,3	528	847	3	600	425	7,8	1197	917	11	3038	2400
WR				5,1	809	66	6,2	1560	44	9,8	1200	262	12,3	1500	255	19	950	601
WVT				3,6	149	283	3,3	793	847									
WRT				5,1	136	66	6,2	1560	44									
WK				4,9	594	41	4,9	1388	139	10	750	179	11,4	650	315			
WEV							1,2	493	844	5,9		678						
WER							0,7	883	37	8,7	1280	131						
WKR							6,1	1361	93	8,7	1250	272						
WERT							0,7	883	37	8,7	1280	131						
WEVT							1,2	686	844	5,9		678						

Size Type	18			30			40			50			60			80		
	F	Mb	Mv	F	Mb	Mv	F	Mb	Mv	F	Mb	Mv	F	Mb	Mv	F	Mb	Mv
quad® elements																		
W	4	634	61	7,8	960	68	5,8	1788	159									
WR	5	1650	168	7,6	960	128	11,8	2200	272									
WRT	5,7	1475	166	7,6	960	128	11,8	2200	272									
WKR	5,7	1365	172	7,5	1050	510	11,8	2200	272									
WVR	6,1	618	70	8,4	1050	128	7,5	1800	1800									
WRV	6,2	1000	325	7,5	1200	46	7,5	2200	272									
WER	6,1	1139	49	2,7	1020	450	11,8	2200	272									
WV	5	410	534	8,1	1212	450	7,5	2022	1800	20,1								
WVT	5,1	411	524	6,3	1229	450	7,5	2022	1800	20,1								
WKV	5,7	781	350	8,1	1256	459	7,5	2022	1800									
WEV	4,5	527	350	2,8	897		7,5	2022	1800									

Solid Clamps

Angle clamps

Right angle tube connector

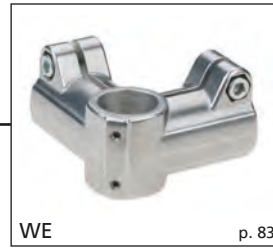
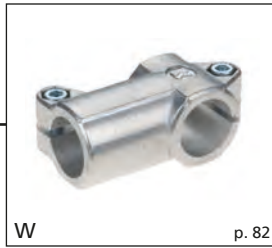

Industrial design

Block form

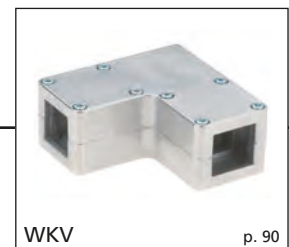
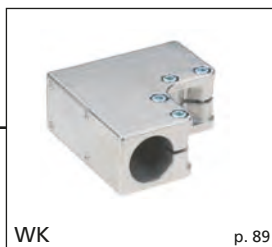

quad® elements



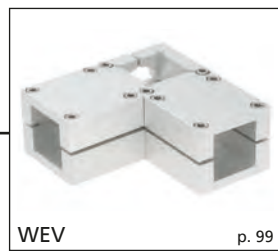
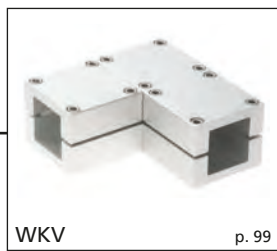
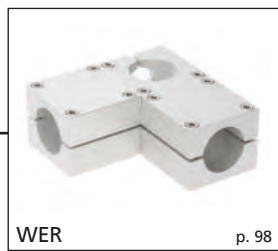
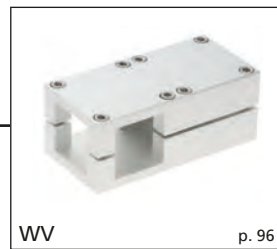
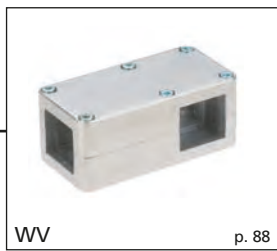
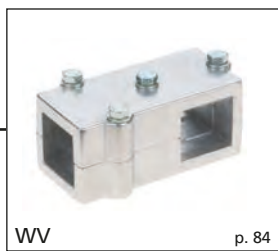

Solid Clamps

Angle clamps

Order instruction:

- Standard equipment premounted zinc plated screws
- Clamping levers have to be ordered separately Delivery unassembled See table last column and page 244

On request:

- Stainless steel screws
- Ball-polished
- Colour

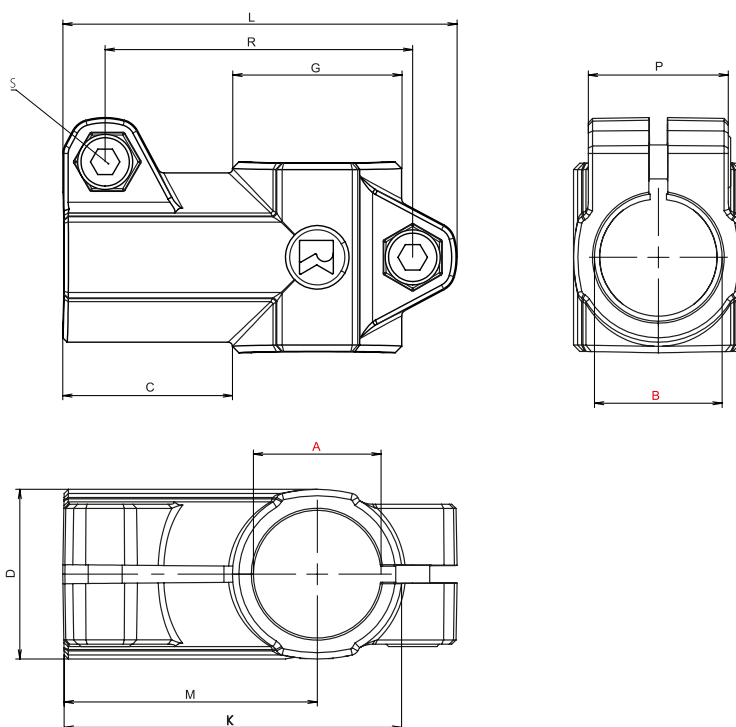

W - Industrial design

[mm]

Code No.	Type	A	B	C	D	E	G	K	L	M	P	R	m [g]	Clamping lever S Code No.
111200000200	W 12	12,1	12,1	28	25	23	25	56	66	43	23	49	97	90209
111400000200	W 14	14,1	14,1										90	
111500000200	W 15	15,1	15,1										87	
111600000200	W 16	16,1	16,1										83	
111800000200	W 18	18,1	18,1										75	
112000000200	W 20	20,1	20,1	38	40	33	40	80	93	60	33	72,5	278	9022201
112500000200	W 25	25,1	25,1										240	
	W 28*	*With adapter sleeve R28, see accessories page 245												
113000000200	W 30	30,1	30,1	55	56	40	56	116	134	88	40	108	192	9022201
113200000200	W 32	32,2	32,2										680	
113500000200	W 35	35,15	35,15										623	
114000000200	W 40	40,15	40,15	63	66	45	66	131	149	98	45	123	530	90251
114800000200	W 48	48,22	48,22										759	
115000000200	W 50	50,22	50,22										705	
116000000200	W 60	60,27	60,27	78	80	58	80	160	183	120	58	151	1340	9025301

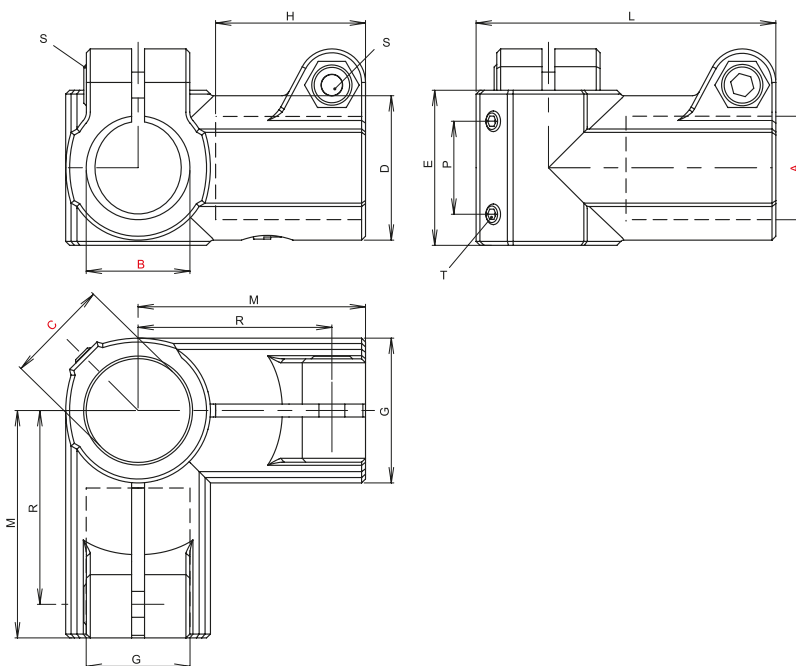

WE - Industrial design

[mm]

Code No.	Type	A	B	C	D	E	G	H	L	M	R	m [g]	T	Clamping lever S Code No.	
	WE28*			30	*With adapter sleeve R28, see accessories page 245										
1130000602005	WE 30	30,1	30,1	30	40	45	40	38	80	60	49	250	M8x15	9022201	
1140000602005	WE 40	40,15	40,15	40,15	56	60	56	58	116	88	70	708	M8x10	90250	
1150000602005	WE 50	50,22	50,22	50,22	66	70	66	70	136	108	90	710	M10x15	90251	

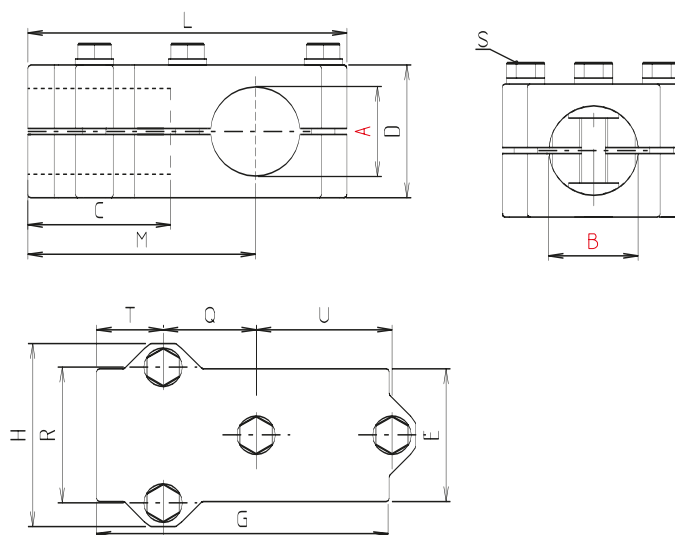

WR - Industrial design

[mm]

Code No.	Type	A	B	C	D	E	G	H	L	M	Q	R	T	U	m [g]	Clamping lever S Code No.
112500030200	WR 25	25,2	25,2	46	45	45	100	62	108	77	31,5	46	23	46	418	9022501
113000030200	WR 30	30,2	30,2												388	
113500030200	WR 35	35,2	35,2	60	60	60	129	75	136	99	40	57	30	57	770	9022801
114000030200	WR 40	40,2	40,2												738	

Solid Clamps

Angle clamps

Order instruction:

- Standard equipment premounted zinc plated screws
- Clamping levers have to be ordered separately Delivery unassembled See table last column and page 244

On request:

- Stainless steel screws
- Ball-polished
- Colour

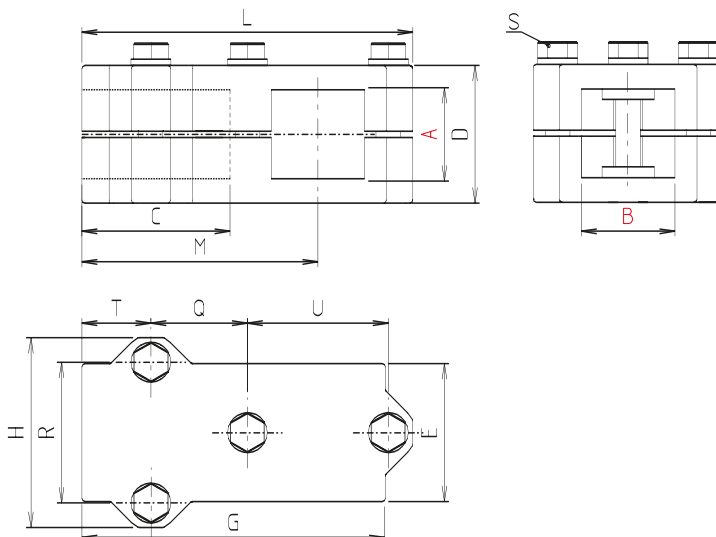

WV - Industrial design

Code No.	Type	A	B	C	D	E	G	H	L	M	Q	R	T	U	m [g]	Clamping lever S Code No.
112500050200	WV 25	25,3	25,3	46	45	45	100	62	108	77	31,5	46	23	46	389	9022501
113000050200	WV 30	30,3	30,3												361	
113500050200	WV 35	35,4	35,4	60	60	60	129	75	136	99	40	57	30	57	731	9022801
114000050200	WV 40	40,4	40,4												722	

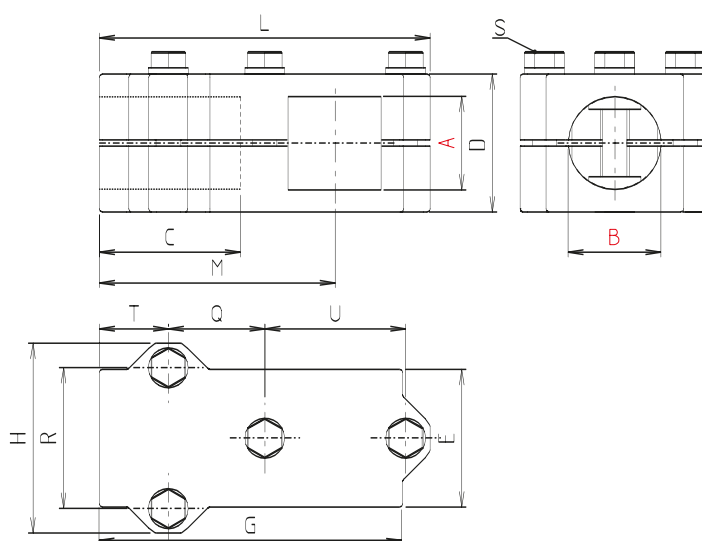

WVR - Industrial design

Code No.	Type	A	B	C	D	E	G	H	L	M	Q	R	T	U	m [g]	Clamping lever S Code No.
113000040200	WVR 30	30,3	30,2	46	45	45	100	62	108	77	31,5	46	23	46	358	9022501
114000040200	WVR 40	40,4	40,2	60	60	60	129	75	136	99	40	57	30	57	698	9022801

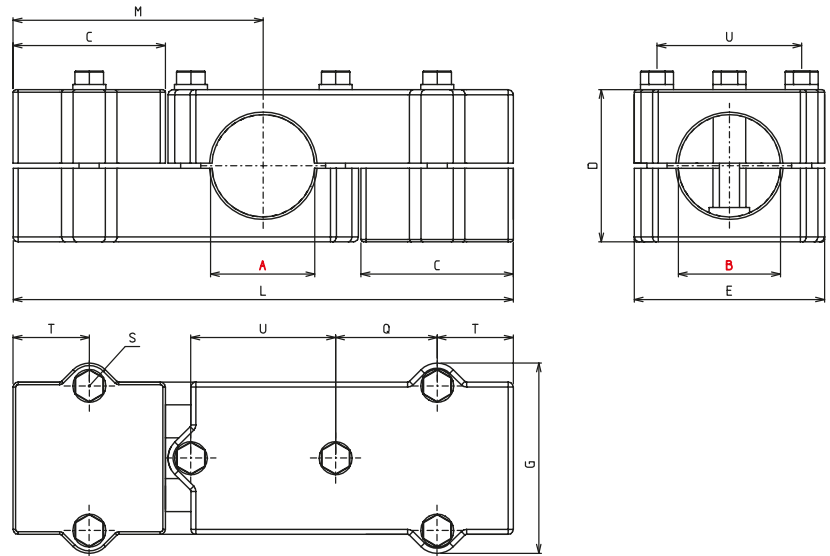

WRT - Industrial design

Code No.	Type	A	B	C	D	E	G	L	M	Q	R	T	U	[mm]	
														m [g]	Clamping lever S Code No.
1125001002000	WRT 25	25,2	25,2	46	45	45	62	154	77	31,5	46	23	46	621	9022501
1130001002000	WRT 30	30,2	30,2											585	
1135001002000	WRT 35	35,2	35,2	60	60	60	75	196	99	40	57	30	57	1148	9022801
1140001002000	WRT 40	40,2	40,2											1104	

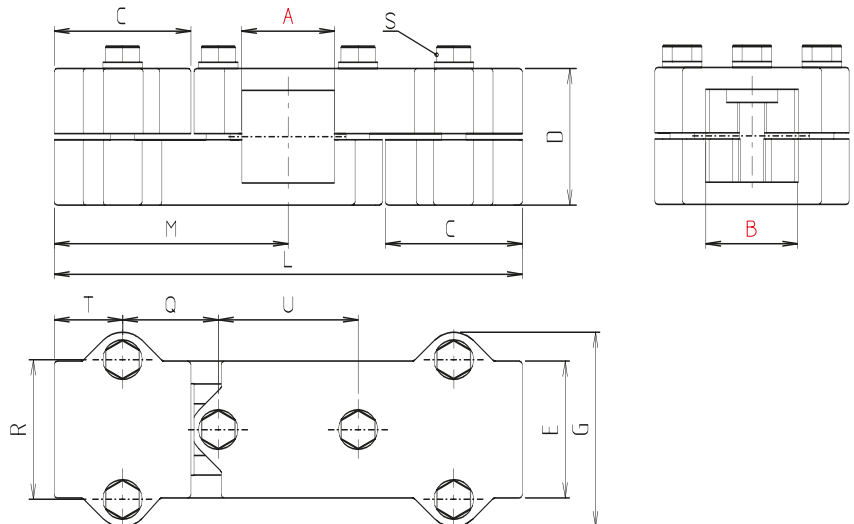

WVT - Industrial design

Code No.	Type	A	B	C	D	E	G	L	M	Q	R	T	U	[mm]	
														m [g]	Clamping lever S Code No.
1125001102000	WVT 25	25,3	25,3	46	45	45	62	154	77	31,5	46	22,5	46	601	9022501
1130001102000	WVT 30	30,3	30,3											549	
1135001102000	WVT 35	35,4	35,4	60	60	60	75	196	99	40	57	30	57	1084	9022801
1140001102000	WVT 40	40,4	40,4											1044	

Solid Clamps

Angle clamps

Order instruction:

- Standard equipment premounted zinc plated screws
- Clamping levers have to be ordered separately Delivery unassembled See table last column and page 244
- Stainless steel screws
- Ball-polished
- Colour

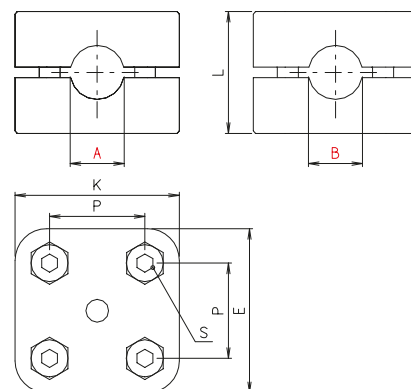

RRW - Block form

[mm]

Code No.	Type	A	B	E	K	L	P	S	m [g]
290800040266	RRW 8	8	8	31	31	23	18	M4x18	47
291000040266	RRW 10	10	10						46

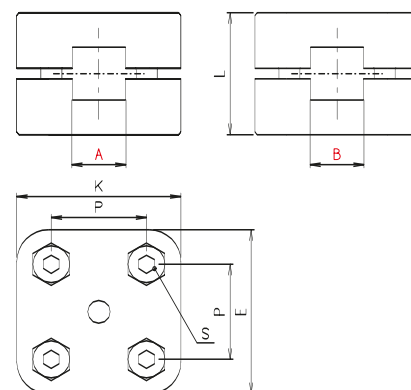

VVW - Block form

[mm]

Code No.	Type	A	B	E	K	L	P	S	m [g]
291000050266	VVW 10	10	10	31	31	23	18	M4x18	42

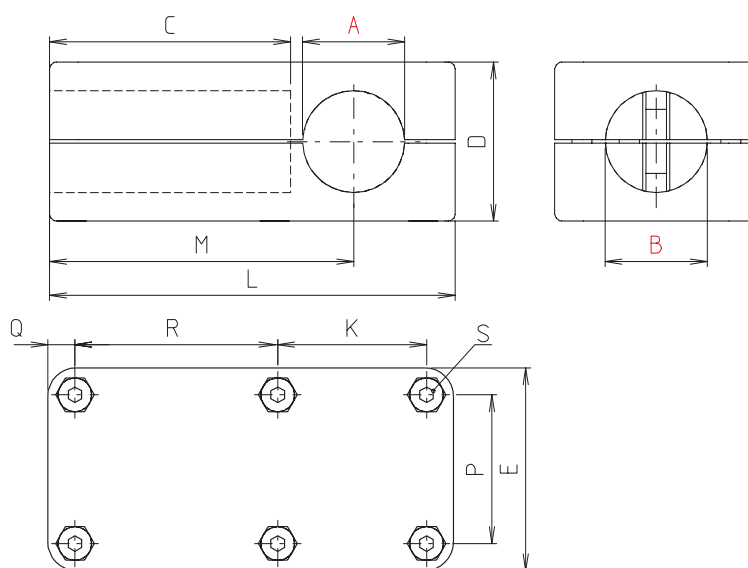

WR - Block form

[mm]

Code No.	Type	A	B	C	D	E	K	L	M	P	Q	R	m [g]	Clamping lever S Code No.
213000030266	WR 30	30,2	30,2	60	48	60	44	120	90	44	8	60	499	9021401
213500030266	WR 35	35,3	35,3	70	62	70	53	140	105	53	9	70	782	9021601
214000030266	WR 40	40,2	40,2										750	
214500030266	WR 45	45,3	45,3	86	79	86	70	161	118	65	11		1535	9022901
214800030266	WR 48	48,3	48,3										1528	
215000030266	WR 50	50,3	50,3									1490		
216000030266	WR 60	60,4	60,4	100	90	100	84	190	140	78	11	84	2015	9023001
218000030266	WR 80	80,5	80,5	130	122	130	100	260	195	115	15	115	5030	9024601

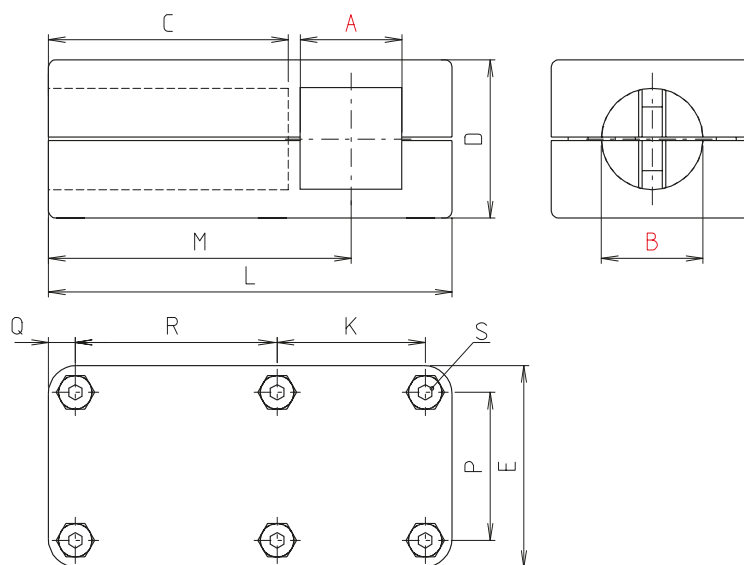

WVR - Block form

[mm]

Code No.	Type	A	B	C	D	E	K	L	M	P	Q	R	m [g]	Clamping lever S Code No.
215000150266	WVR 50	50,3	50,3	86	79	86	70	161	118	65	11	70	1410	9022901
216000150266	WVR 60	60,4	60,4	100	90	100	84	190	140	78	11	84	1920	9023001

Solid Clamps

Angle clamps

Order instruction:

- Standard equipment premounted zinc plated screws
- Clamping levers have to be ordered separately Delivery unassembled See table last column and page 244

On request:

- Stainless steel screws
- Ball-polished
- Colour

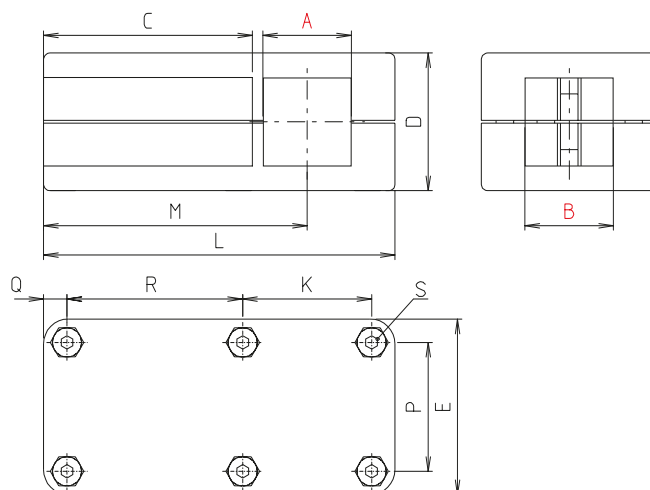

WV - Block form

Code No.	Type	A	B	C	D	E	K	L	M	P	Q	R	m [g]	Clamping lever S Code No.
213000050266	WV 30	30,3	30,3	60	48	60	44	120	90	44	8	60	482	9021401
213500050266	WV 35	35,4	35,4	70	62	70	53	140	105	53	9	70	765	9021601
214000050266	WV 40	40,4	40,4										716	
215000050266	WV 50	50,5	50,5	86	79	86	70	161	118	65	11	70	1406	9022901
216000050266	WV 60	60,6	60,6	100	90	100	84	190	140	78		84	1925	9023001
218000050266	WV 80	80,7	80,7	130	122	130	115	260	195	100	15	115	4680	9024601

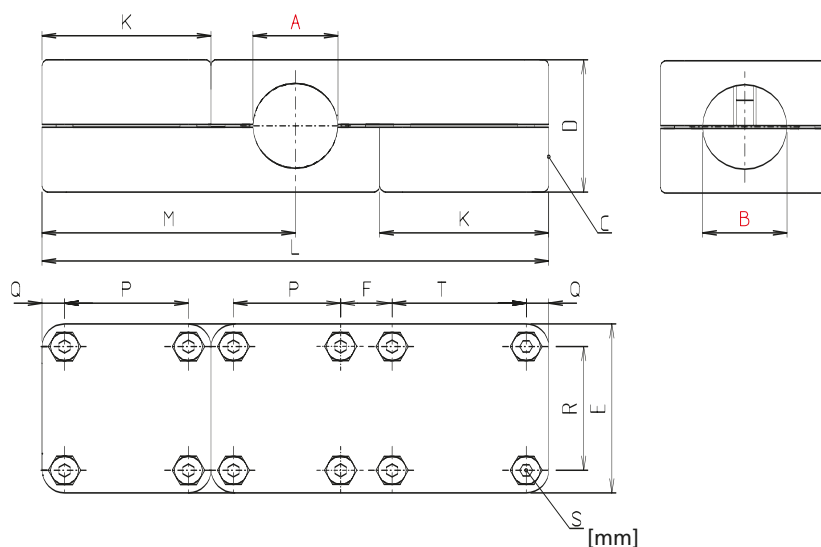

WRT - Block form

Code No.	Type	A	B	C	D	E	F	K	L	M	P	Q	R	T	m [g]	Clamping lever S Code No.
2130001002666	WRT 30	30,2	30,2	30	48	60	15	60	180	90	44	8	44	44	753	9021401
2140001002666	WRT 40	40,2	40,2	40	62	70	0	70	210	105	53	9	53	53	1151	9021601

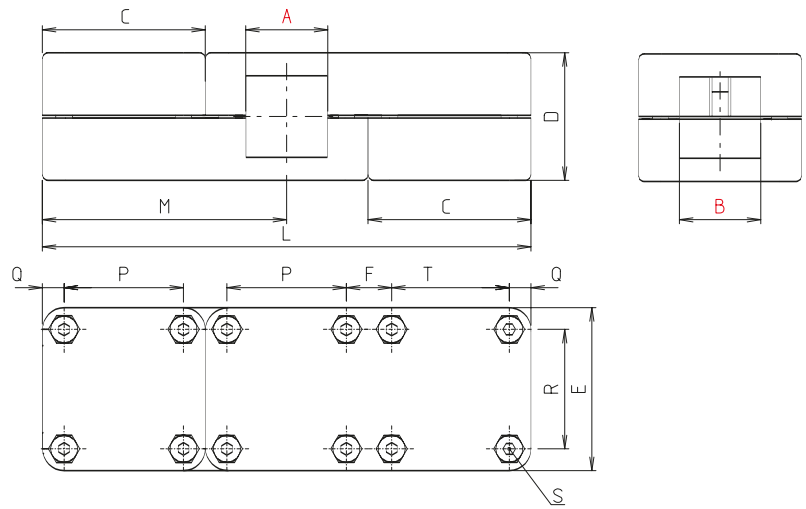
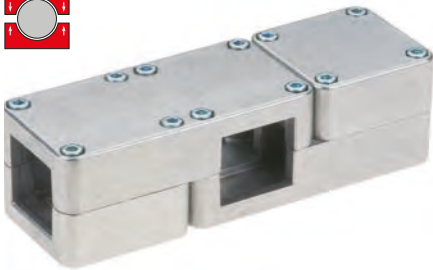

WVT - Block form

[mm]

Code No.	Type	A	B	C	D	E	F	L	M	P	Q	R	T	m [g]	Clamping lever S Code No.
2130001102666	WVT 30	30,3	30,3	60	48	60	15	180	90	44	8	44	44	732	9021401
2140001102666	WVT 40	40,4	40,4	70	62	70	0	210	105	53	9	53	53	1080	9021601

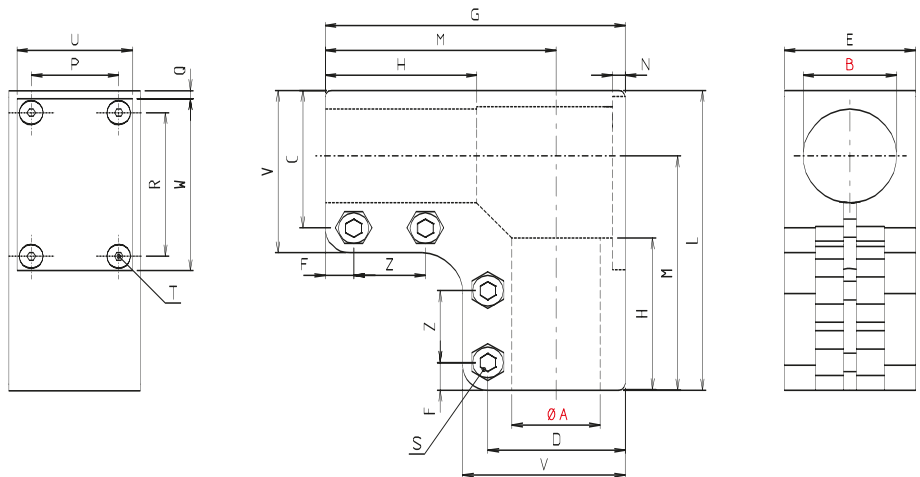

WK - Block form

[mm]

Code No.	Type	A	B	C	D	E	F	G	H	K	L	M	N	P	Q	R	U	V	W	Z	T	m [g]	Clamping lever S Code No.
213000090266	WK 30	30,1	30,1	44	44	42	9	96	48	48	96	75	1	28	2,5	46	37	52	55	32	M4x6	449	9021301
214000090266	WK 40	40,2	40,2	70	70	54	12	128	65	65	128	100	2,5	38		61	49	70	74	43		1008	9022501
214800090266	WK 48	48,2	48,2	70	70	65	12	148	75	75	148	115	2,5	49	2,5	71	60	80	84	58	M4x6	1533	9022701
215000090266	WK 50	50,2	50,2																			1474	9022801
216000090266	WK 60	60,3	60,3	80	80	80	25	170	110	110	170	130	4	-	-	-	-	80	-	0	-	2232	9024501

Solid Clamps

Angle clamps

Order instruction:

- Standard equipment premounted zinc plated screws
- Clamping levers have to be ordered separately Delivery unassembled See table last column and page 244
- Stainless steel screws
- Ball-polished
- Colour

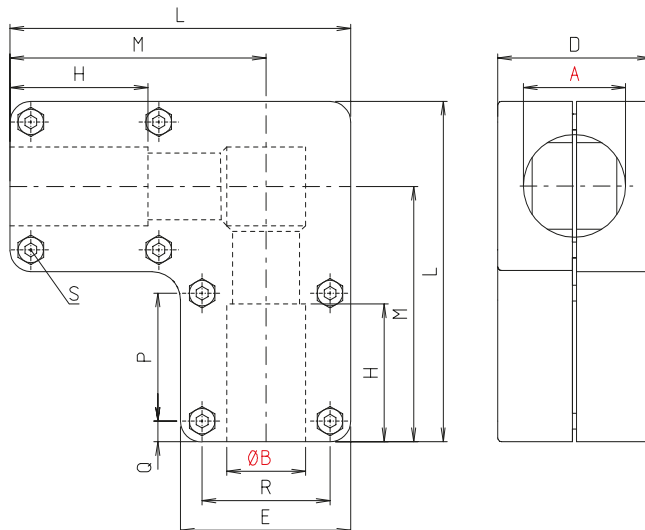

WKR - Block form

[mm]

Code No.	Type	A	B	D	E	H	L	M	P	Q	R	m [g]	Clamping lever S Code No.	
213200010266	WKR 32	32,2	32,2	62	70	70	141	106	53	8,5	53	1667	9021601	
213500010266	WKR 35	35,2	35,2									1328		
214000010266	WKR 40	40,2	40,2									1230		
214200010266	WKR 42	42,3	42,3	76	86	85	173	130	65	10,5	65	2639		9022901
214800010266	WKR 48	48,3	48,3									2595		
215000010266	WKR 50	50,3	50,3	2380										

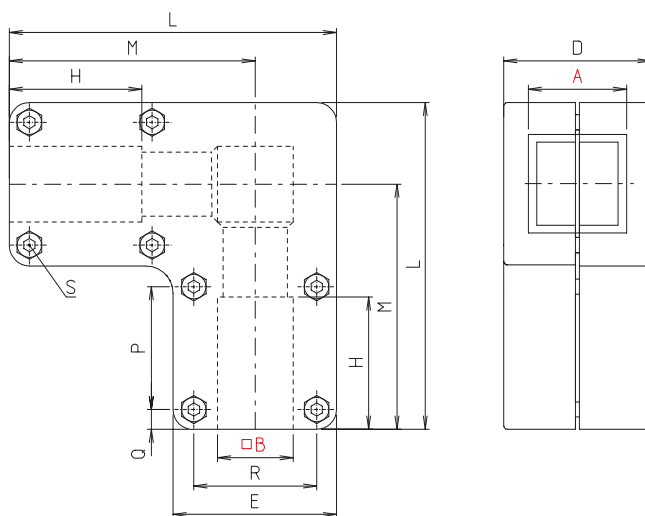

WKV - Block form

[mm]

Code No.	Type	A	B	D	E	H	L	M	P	Q	R	m [g]	Clamping lever S Code No.
213500020266	WKV 35	35,4	35,4	62	70	70	141	106	53	8,5	53	1258	9021601
214000020266	WKV 40	40,4	40,4									1192	

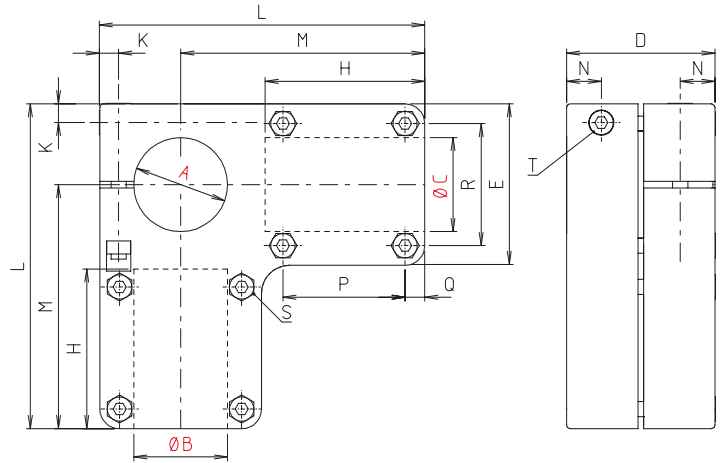

WER - Block form

[mm]

Code No.	Type	A	B	C	D	E	H	K	L	M	N	P	Q	R	m [g]	S	T
																Clamping lever Code No.	
2132000702666	WER 32	32,2	32,2	32	62	70	70	9	141	106	16	53	8,5	53	1448	9021601	9021601
2140000702666	WER 40	40,2	40,2	40													
2148000702666	WER 48	48,2	48,3	48	76	86	85	10	173	130	19	65	11	65	2644	9022901	9022901
2150000702666	WER 50	50,2	50,3	50													

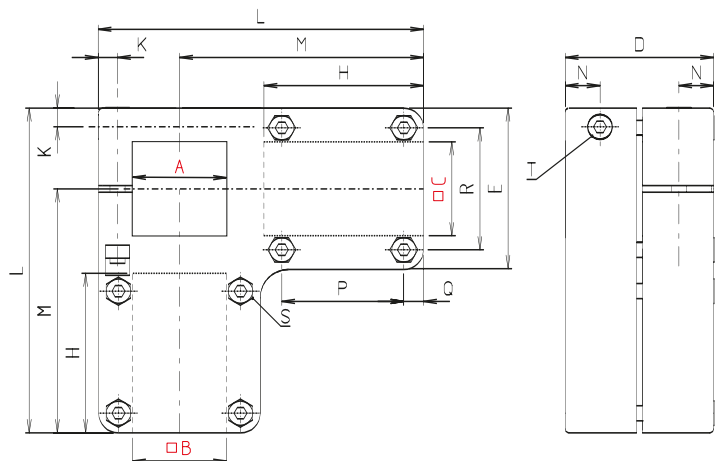
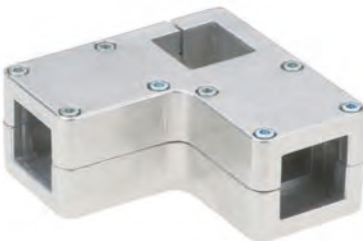

WEV - Block form

[mm]

Code No.	Type	A	B	C	D	E	H	L	M	P	Q	R	m [g]	S	T
														Clamping lever Code No.	
2135000802666	WEV 35	35,4	35,4	35	62	70	70	141	106	53	9	53	1286	9021601	9021601
2140000802666	WEV 40	40,4	40,4	40											

Solid Clamps

Angle clamps

Order instruction:

- Standard equipment premounted zinc plated screws
- Clamping levers have to be ordered separately Delivery unassembled See table last column and page 244

- Stainless steel screws
- Ball-polished
- Colour

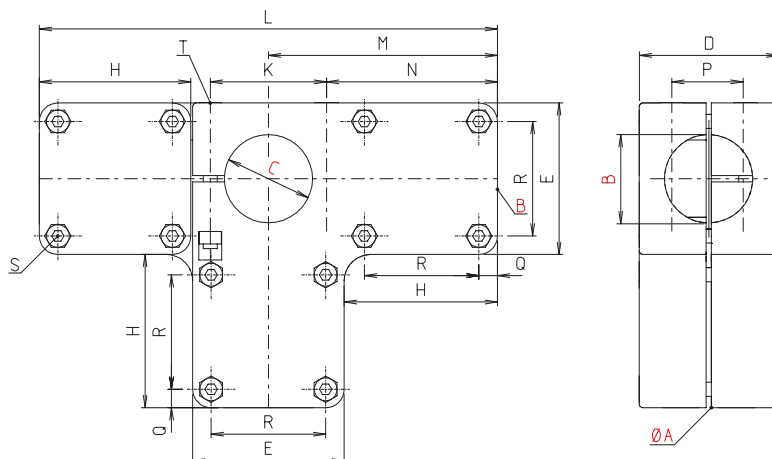
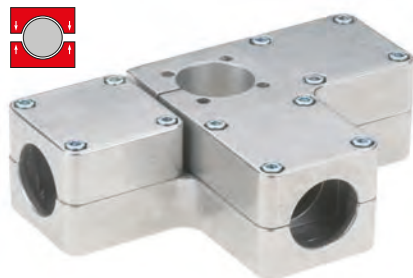

WERT - Block form

[mm]

Code No.	Type	A	B	C	D	E	H	K	L	M	N	P	Q	R	m [g]	Clamping lever S Code No.
2132001202666	WERT 32	32,2	32,2	32	62	70	70	53	212	106	80	33,5	8,5	53	1864	9021601
2135001202666	WERT 35	35,2	35,2	35											1738	
2140001202666	WERT 40	40,2	40,2	40											1678	
2148001202666	WERT 48	48,3	48,3	48	76	86	86	66	260	130	97	41	10,5	65	3512	9022901
2150001202666	WERT 50	50,3	50,3	50											3360	

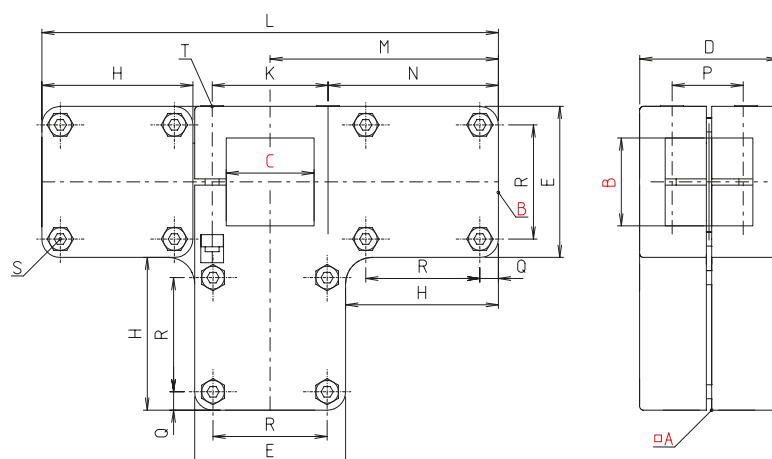
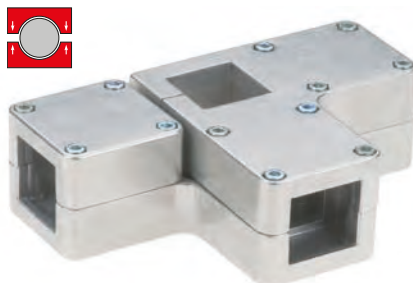

WEVT - Block form

[mm]

Code No.	Type	A	B	C	D	E	H	K	L	M	N	P	Q	R	m [g]	Clamping lever S Code No.
2135001302666	WEVT 35	35,4	35,4	35	62	70	70	53	212	106	80	33,5	8,5	53	1673	9021601
2140001302666	WEVT 40	40,4	40,4	40											1573	



Solid Clamps

Angle clamps

Order instruction:

- Quad® with stainless steel screws
- Clamping levers have to be ordered separately Delivery unassembled See table last column and page 244

On request quad®:

- Black anodized

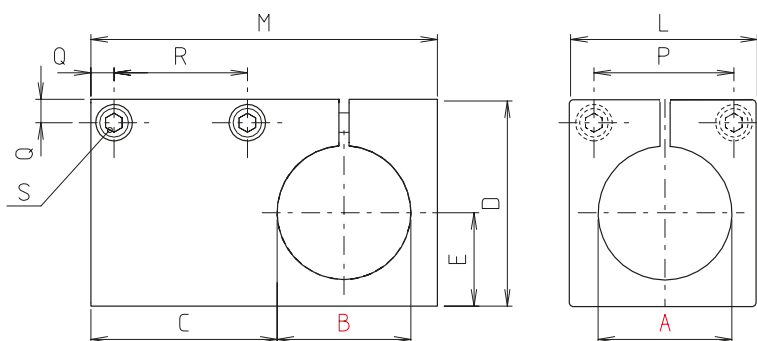

W - quad®

Code No.	Type	A	B	C	D	E	L	M	P	Q	R	m [g]	Clamping lever S Code No.
513000000300	W 30	30,1	30,1	42	49	21	42	78	28	7	26	251	9300101
514000000300	W 40	40,1	40,1	56	62	28	56	104	42	7	40	544	9301401

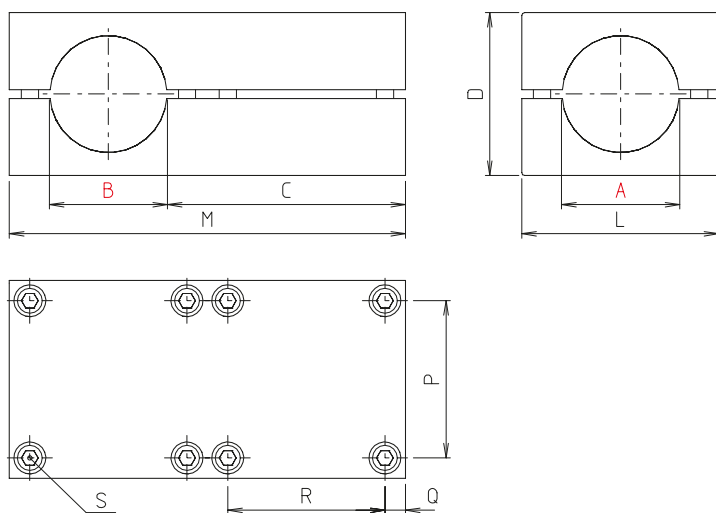

WR - quad®

Code No.	Type	A	B	C	D	L	M	P	Q	R	m [g]	Clamping lever S Code No.
513000030300	WR 30	30,1	30,1	69	42	56	112	42	7	42	450	9300101
514000030300	WR 40	40,2	40,2	82	56	68	136	54	7	54	812	9301401
515000030300	WR 50	50,3	50,3	102	70	85	170	67	9	67	1633	9300401
516000030300	WR 60	60,3	60,3	127	97	105	210	85	10	85	-	9022801

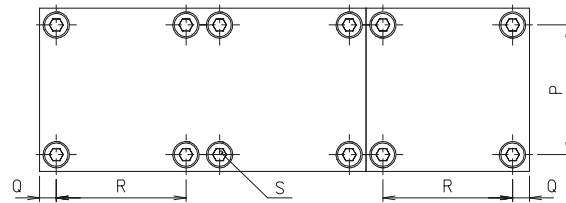
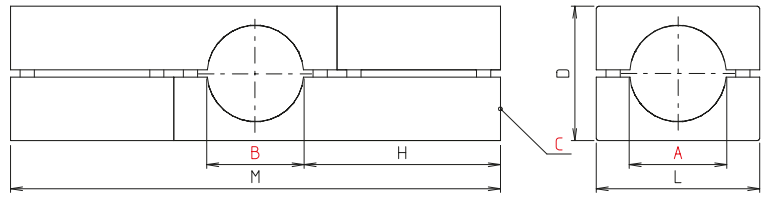

WRT - quad®

[mm]

Code No.	Type	A	B	C	D	H	L	M	P	Q	R	m [g]	Clamping lever S Code No.
5130001003000	WRT 30	30,1	30,1	30,1	42	69	56	168	42	7	42	702	9300101
5140001003000	WRT 40	40,2	40,2	40,2	56	82	68	204	54	7	54	1257	9301401
5150001003000	WRT 50	50,3	50,3	50,3	70	102	85	255	67	9	67	2563	9300401

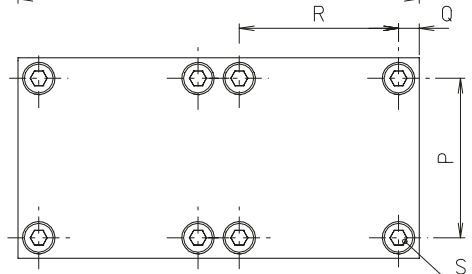
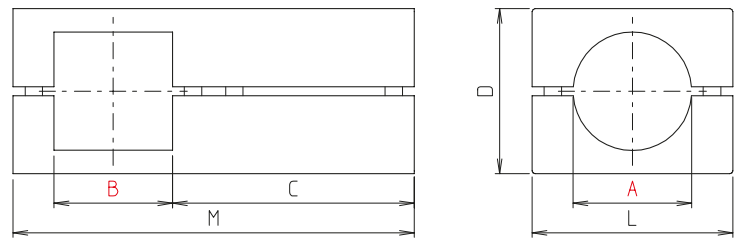

WVR - quad®

[mm]

Code No.	Type	A	B	C	D	L	M	P	Q	R	m [g]	Clamping lever S Code No.
513000150300	WVR 30	30,2	30,1	69	42	56	112	42	7	42	430	9300101
514000150300	WVR 40	40,3	40,2	82	56	68	136	54	7	54	772	9301401
515000150300	WVR 50	50,4	50,3	102	70	85	170	67	9	67	1580	9300401

Solid Clamps

Angle clamps

Order instruction:

- Quad® with stainless steel screws
- Clamping levers have to be ordered separately Delivery unassembled
See table last column and page 244

On request quad®:

- Black anodized

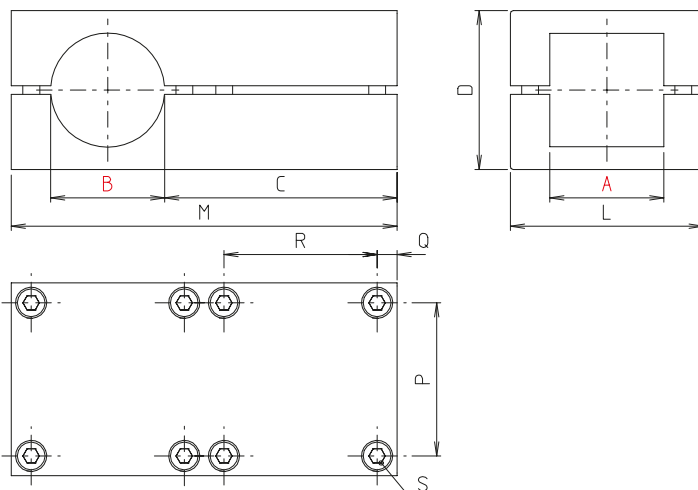

WRV - quad®

[mm]

Code No.	Type	A	B	C	D	L	M	P	Q	R	m [g]	Clamping lever S Code No.
513000140300	WRV 30	30,1	30,2	69	42	56	112	42	7	42	400	9300101
514000140300	WRV 40	40,2	40,3	82	56	68	136	54	7	54	702	9301401
515000140300	WRV 50	50,3	50,4	102	70	85	170	67	9	67	1412	9300401
516000140300	WRV 60	60,3	60,3	127	97	105	210	85	10	85	-	9022801

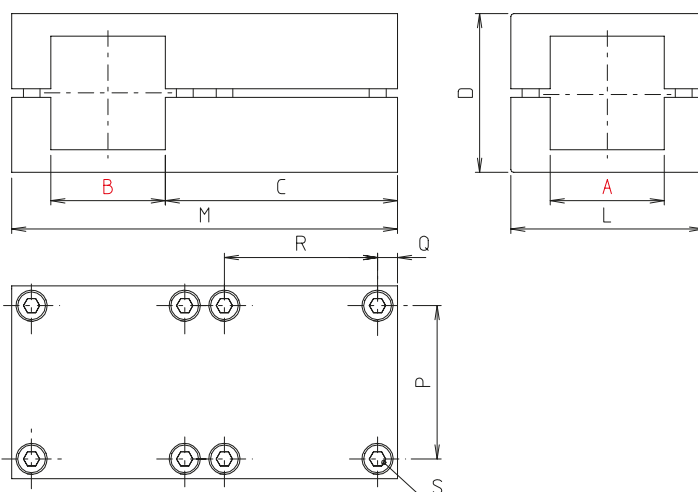

WV - quad®

[mm]

Code No.	Type	A	B	C	D	L	M	P	Q	R	m [g]	Clamping lever S Code No.
513000050300	WV 30	30,2	30,2	69	42	56	112	42	7	42	387	9300101
514000050300	WV 40	40,3	40,3	82	56	68	136	54	7	54	693	9301401
515000050300	WV 50	50,4	50,4	102	70	85	170	67	9	67	1370	9300401
516000050300	WV 60	60,4	60,4	127	97	105	210	85	10	85	-	9022801
518000050300	WV 80	80,4	80,4	149	112	126	252	100	13	100	4200	9300801

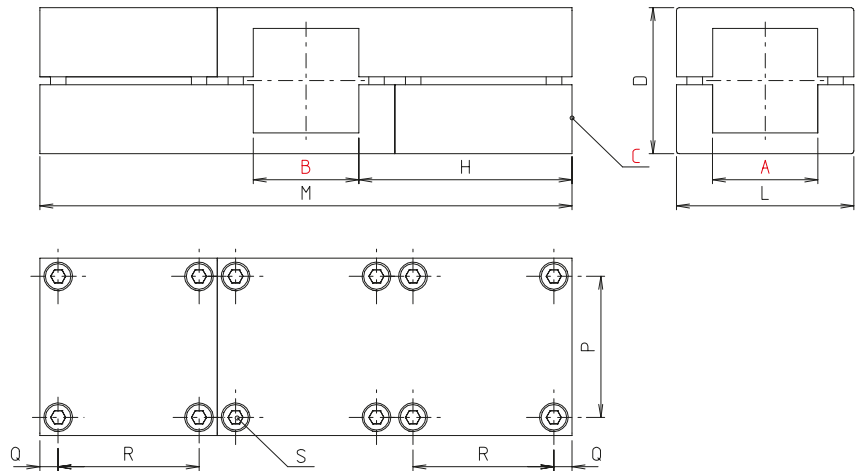
WVT - quad®

[mm]

Code No.	Type	A	B	C	D	H	L	M	P	Q	R	m [g]	Clamping lever S Code No.
5130001103000	WVT 30	30,2	30,2	30,2	42	69	56	168	42	7	42	667	9300101
5140001103000	WVT 40	40,3	40,3	40,3	56	82	68	204	54	7	54	1168	9301401
5150001103000	WVT 50	50,4	50,4	50,4	70	102	85	255	67	9	67	2155	9300401
5180001103000	WVT 80	80,4	80,4	80,4	112	159	126	378	100	13	100	6782	9300801

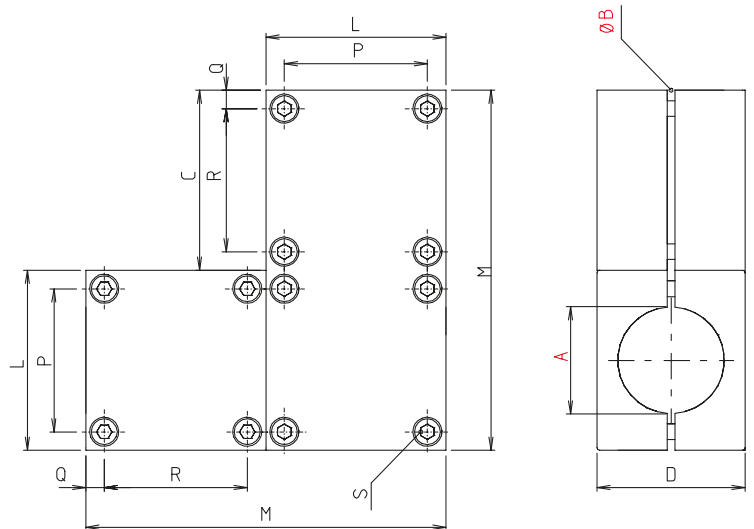
WKR - quad®

[mm]

Code No.	Type	A	B	C	D	L	M	P	Q	R	m [g]	Clamping lever S Code No.
513000010300	WKR 30	30,1	30,1	56	42	56	112	42	7	42	702	9300101
514000010300	WKR 40	40,2	40,2	68	56	68	136	54	7	54	1257	9301401
515000010300	WKR 50	50,3	50,3	85	70	85	170	67	9	67	2563	9300401

Solid Clamps

Angle clamps

Order instruction:

- Quad® with stainless steel screws
- Clamping levers have to be ordered separately Delivery unassembled See table last column and page 244

On request quad®:

- Black anodized

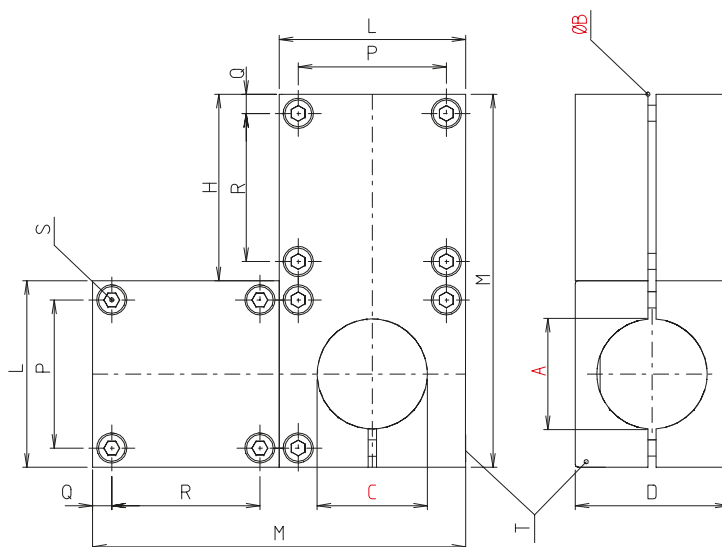

WER - quad®

[mm]

Code No.	Type	A	B	C	D	H	L	M	P	Q	R	m [g]	S	T
													Clamping lever Code No.	
5130000703000	WER 30	30,1	30,1	30,1	42	56	56	112	42	7	42	725	9300101	9300101
5140000703000	WER 40	40,2	40,2	40,2	56	68	68	136	54	7	54	1311	9301401	9301401
5150000703000	WER 50	50,3	50,3	50,3	70	85	85	170	67	9	67	2627	9300401	902161

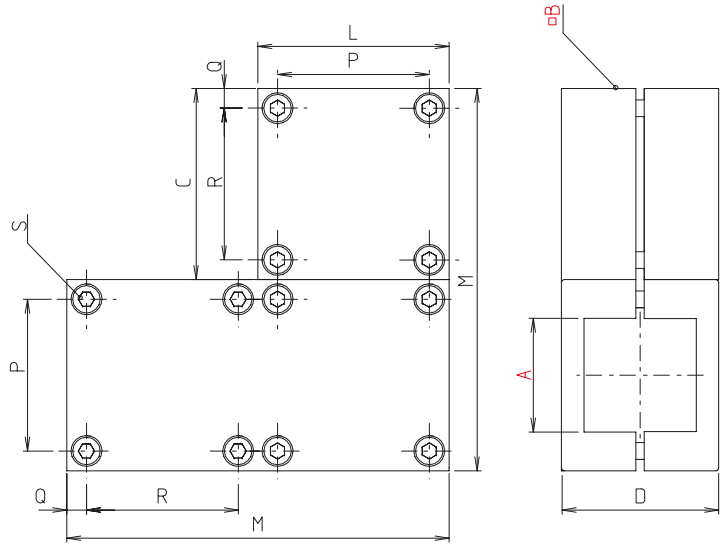

WKV - quad®

[mm]

Code No.	Type	A	B	C	D	L	M	P	Q	R	m [g]	Clamping lever S Code No.
513000020300	WKV 30	30,2	30,2	56	42	56	112	42	7	42	634	9300101
514000020300	WKV 40	40,3	40,3	68	56	68	136	54	7	54	1133	9301401
515000020300	WKV 50	50,4	50,4	85	70	85	170	67	9	67	2274	9300401

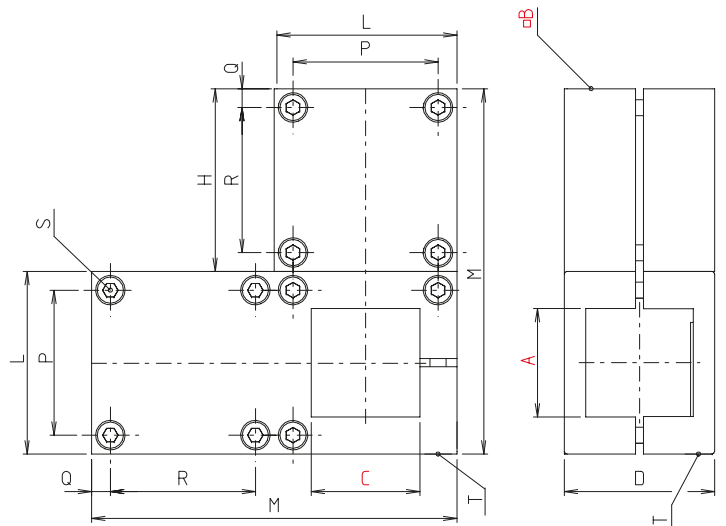

WEV - quad®

[mm]

Code No.	Type	A	B	C	D	H	L	M	P	Q	R	m [g]	S	T
													Clamping lever Code No.	
5130000803000	WEV 30	30,2	30,2	30,2	42	56	56	112	42	7	42	634	9300101	9300101
5140000803000	WEV 40	40,3	40,3	40,3	56	68	68	136	54	7	54	1133	9301401	9301401
5150000803000	WEV 50	50,4	50,4	50,4	70	85	85	170	67	9	67	2274	9300401	902161

Solid Clamps

Base clamps

Version:

- Base clamps



delivery
from stock

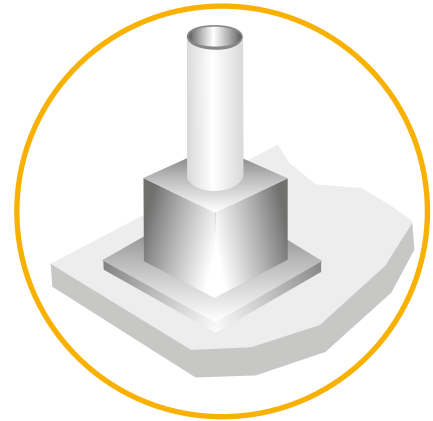

Single-piece elements

- For the quick and inexpensive installation



Industrial design

- Cast aluminium
- Great variety
- Single-piece elements

quad® elements

- Extruded aluminium
- Maximum torque loads
- High-quality anodized surface
- Single- and Multi-piece elements



Multi-piece elements

- Also suitable for subsequent assembly and expansion



quad® elements

- Extruded aluminium
- Maximum torque loads
- High-quality anodized surface
- Single- and Multi-piece elements

Block form

- Cast aluminium
- Higher torque loads
- Plain surface
- Multi-piece elements

Loads base clamps

Attention!

The data in the chart do not ensure a guarantee of quality or a warrant characteristic of our products. These are nonbinding standard values which might be not reached in individual cases due to the temperature or surface finish of the clamping profile.

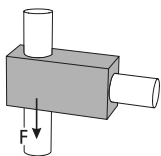

Adhesion force F [KN]

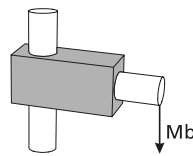

Bending moment Mb [Nm]

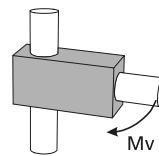

Twisting moment Mv [Nm]

Tightening torque of

clamping screws:

M6: 10 Nm

M8: 25 Nm

M10: 50 Nm

Material data sheet available upon request.

Size	18			30			40			50			60			80		
Type	F	Mb	Mv	F	Mb	Mv	F	Mb	Mv	F	Mb	Mv	F	Mb	Mv	F	Mb	Mv
Industrial design																		
FS				5,7	302	87	7,5	418	121	8,7	1375	150	16	1250	374			
FR							4,5	738	96	5,4	1395	207						
FV				5,6	125	296	2,9	290	623									
FRR				6,7	555	108	5,9	743	91									
FRA										5	600	250	12	1297	256			
FVA										5,9	1015	726	8	1750	1155			
FRAA										7,7	971	257	12	1750	263			

Size	18			30			40			50			60			80		
Type	F	Mb	Mv	F	Mb	Mv	F	Mb	Mv	F	Mb	Mv	F	Mb	Mv	F	Mb	Mv
Block form																		
FV				3,0	441	213	3,1	811	855	5,9	600	726				18	2125	2250
FRR				4,5	433	80	5,7	838	58	7,7	600	257				10	2250	692

Size	18			30			40			50			60			80		
Type	F	Mb	Mv	F	Mb	Mv	F	Mb	Mv	F	Mb	Mv	F	Mb	Mv	F	Mb	Mv
quad® elements																		
FS	2,1	418	39	3,9	703	81	5,8	1960	118									
FR	5,6	548	65	7,4	744	121	11,5	1960	272	21,5		950						
FV	3,2	541	338	7,1	881	540	7,5	1960	50	20,1								

Solid Clamps

Base clamps

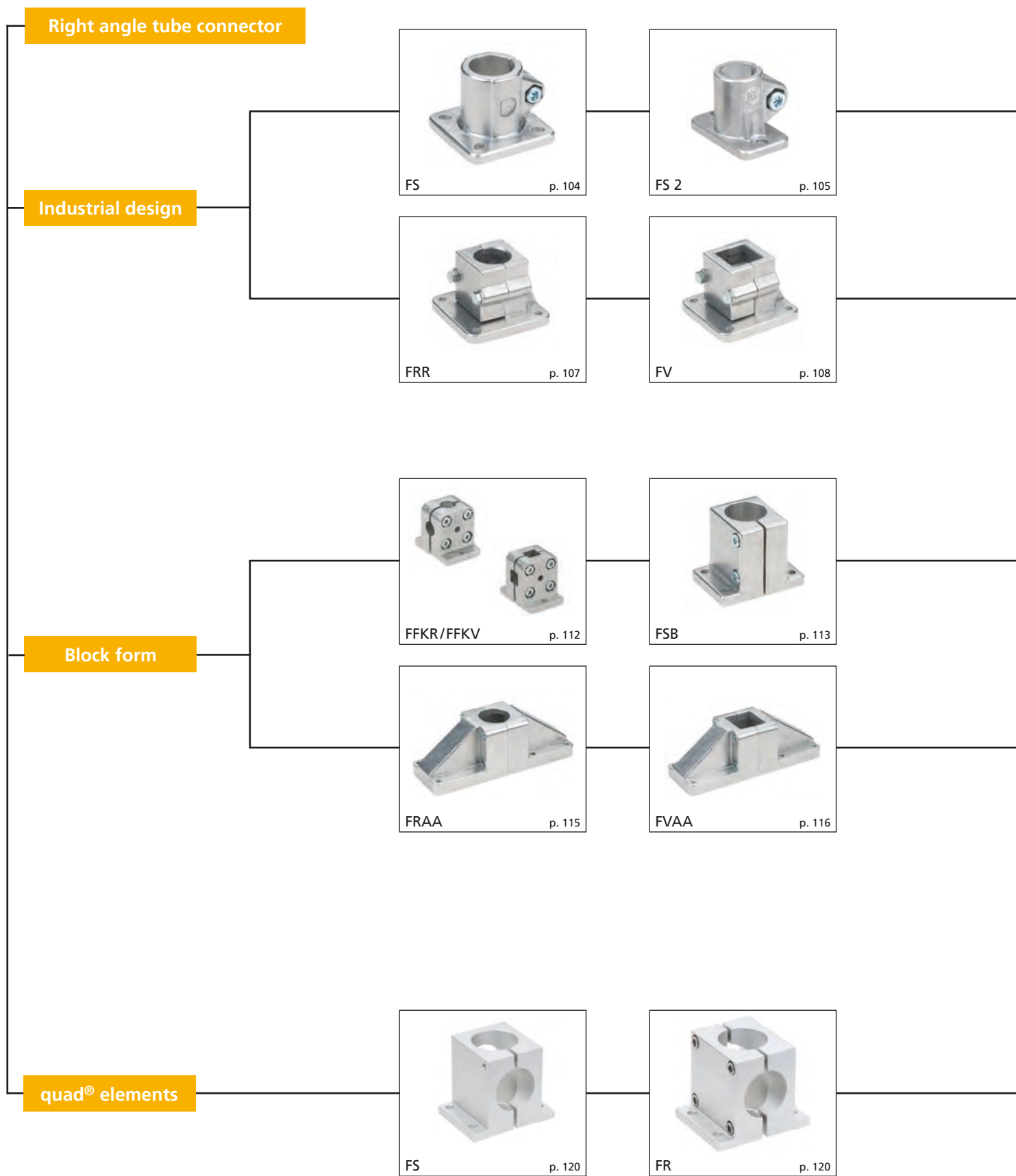

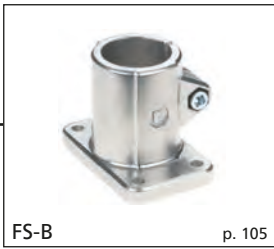

FS-B p. 105



FR p. 106

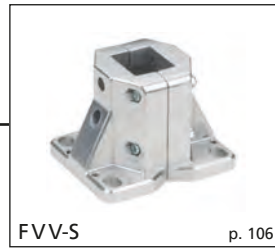

FVV-S p. 106



FVV-D p. 107



FP p. 110



FP FS p. 110



FP FRR p. 110



FP FV p. 111



FV p. 113



FRR p. 114

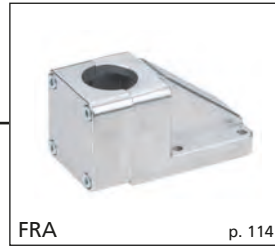

FRA p. 114



FVA p. 115



BAK-80 p. 117

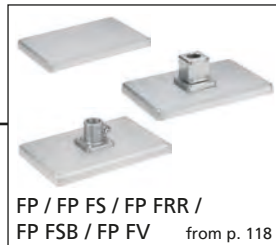

FP / FP FS / FP FRR /
FP FSB / FP FV from p. 118



FV p. 121

Solid Clamps

Base clamps

Order instruction:

- Standard equipment premounted zinc plated screws
- Clamping levers have to be ordered separately Delivery unassembled See table last column and page 244

On request:

- Stainless steel screws
- Ball-polished
- Colour

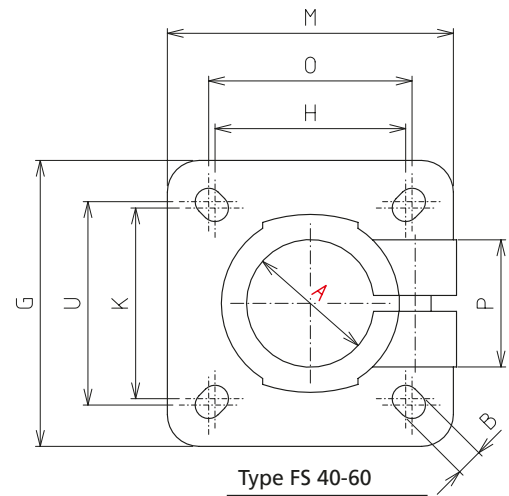
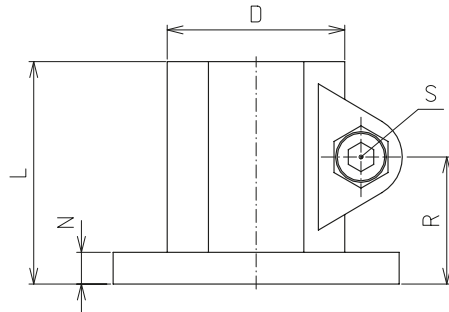
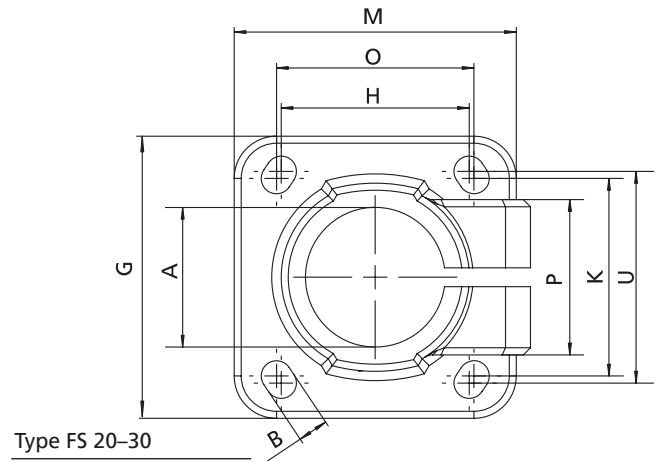

FS - Industrial design

Code No.	Type	A	B	D	G	H	K	L	M	N	O	P	R	U	[mm]	Clamping lever S Code No.
13120000020	FS 12	12,1	6	25	42	28	28	37	42	5	30	23	21	30	65	90209
13140000020	FS 14	14,1													61	
13150000020	FS 15	15,1													58	
13160000020	FS 16	16,1													57	
13180000020	FS 18	18,1													52	
13200000020	FS 20	20,1	7	40	60	40	42	50	60	8	42	33	29	45	186	9022201
13250000020	FS 25	25,1													164	
	FS 28*	*With adapter sleeve R28, see accessories page 245														
13300000020	FS 30	30,1	7	40	60	40	42	50	60	8	42	33	29	45	137	9022201
13320000020	FS 32	32,17	9	56	90	60	60	70	90	10	64	40	40	64	465	90250
13300200020	FS 30(32)	30,1													465	
13350000020	FS 35	35,17													450	
13400000020	FS 40	40,17													385	
13400200020	FS 40(42)	40,17	11	66	105	74	74	85	105	14	80	45	49,5	80	758	90251
13420000020	FS 42	42,22													720	
13480000020	FS 48	48,22													636	
13500000020	FS 50	50,22													603	
13600000020	FS 60	60,27	11	80	120	80	80	100	120	15	89	58	57,5	89	935	9025301
13800000020	FS 80**	80,35	17,5	110	170	120	120	141,4	174,5	22	-	82	119	-	2770	9027001

**Type FS 80 with round hole

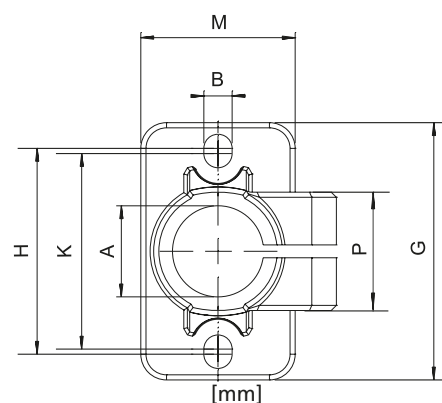
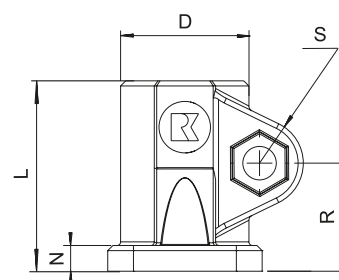

FS 2 - Industrial design

Code No.	Type	A	B	D	G	H	K	L	M	N	P	R	m [g]	Clamping lever S Code No.
13120300020	FS 12-2	12,1	5,5	25	50	40	38	37	30	5	23	21	65	90209
13140300020	FS 14-2	14,1											61	
13150300020	FS 15-2	15,1											58	
13160300020	FS 16-2	16,1											57	
13180300020	FS 18-2	18,1											52	



FS-B - Industrial design

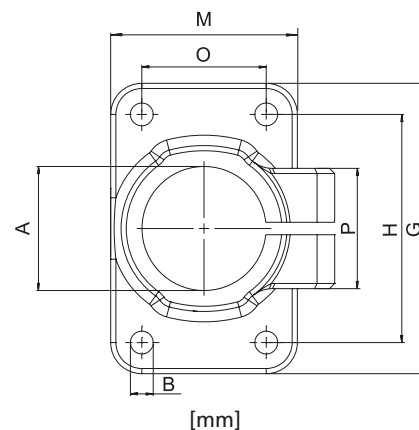
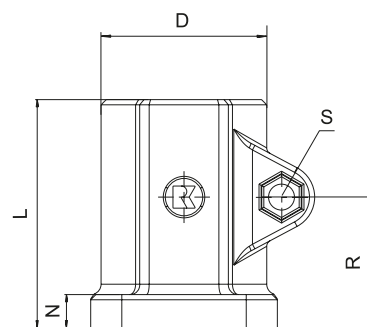

Code No.	Type	A	B	D	G	H	L	M	N	O	P	R	m [g]	Clamping lever S Code No.
13600200020	FS-B 60	60,27	11	80	140	110	110	90	16	60	58	63	920	9025301

Solid Clamps

Base clamps

Order instruction:

- Standard equipment premounted zinc plated screws
- Clamping levers have to be ordered separately Delivery unassembled See table last column and page 244

On request:

- Stainless steel screws
- Ball-polished
- Colour

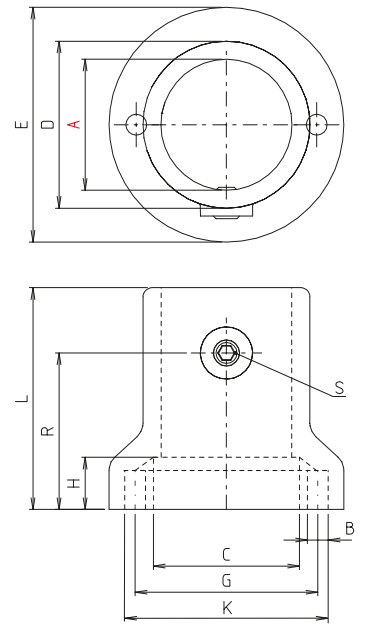

FR - Industrial design

[mm]

Code No.	Type	A	B	C	D	E	G	H	K	L	R	m [g]	Clamping lever S Code No.
13400009020	FR 40	40,2	M8	56	64	90	69	20	77	85	60	474	9024101
13500009020	FR 50	50,2	M8	56	64	90	69	20	77	85	60	359	9024101

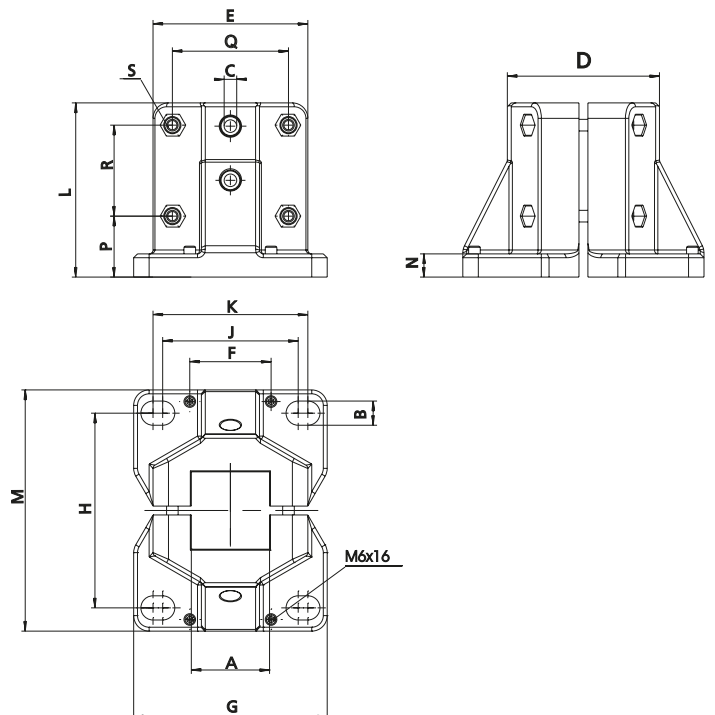

FVV-S - Industrial design

[mm]

Code No.	Type	A	B	C	D	E	F	G	H	J	K	L	M	N	P	Q	S	m [g]
4014312	FVV-S 40	40,4	12,5	7	79	80	42	100	100	70	80	90	125	12	31,5	60	M6x45	805

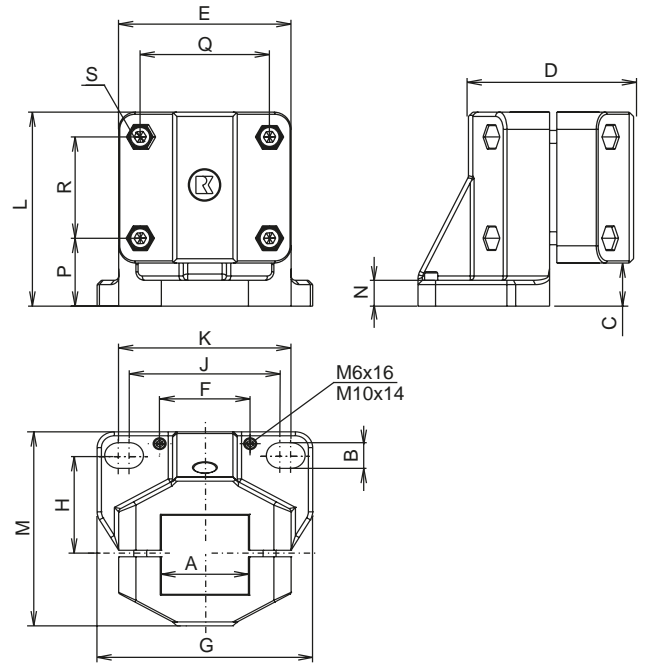

FVV-D - Industrial design

[mm]

Code No.	Type	A	B	C	D	E	F	G	H	J	K	L	M	N	P	Q	R	S	m [g]
4014313	FVV-D 40	40,4	12,5	20	75	80	42	100	50	70	80	90	98	12	31,5	60	47	M6x45	633

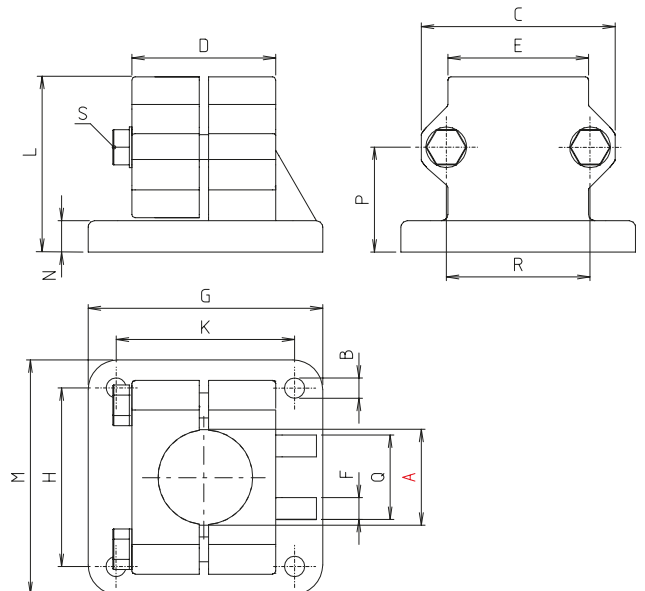

FRR - Industrial design

[mm]

Code No.	Type	A	B	C	D	E	F	G	H	K	L	M	N	P	Q	R	m [g]	Clamping lever S Code No.
13250003020	FRR 25	25,2	7	62	45	45	5	75	57	57	56	75	10	33,5	25	46	303	9022501
13300003020	FRR 30	30,2															287	
13350003020	FRR 35	35,2	9	75	60	60	5	100	76	76	71	100	10	43	25	57	612	9022801
13400003020	FRR 40	40,2															597	

Solid Clamps

Base clamps

Order instruction:

- Standard equipment premounted zinc plated screws
- Clamping levers have to be ordered separately Delivery unassembled See table last column and page 244

On request:

- Stainless steel screws
- Ball-polished
- Colour

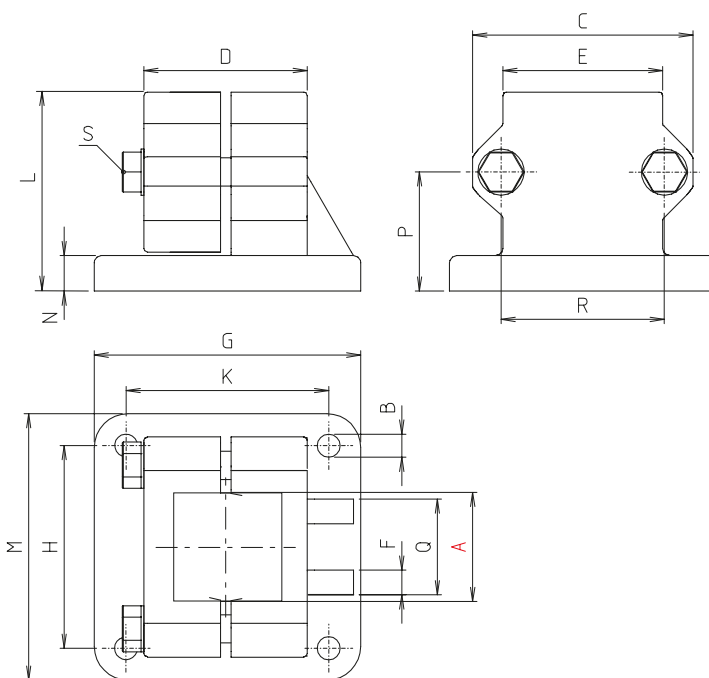

FV - Industrial design

Code No.	Type	[mm]															m [g]	Clamping lever S Code No.
		A	B	C	D	E	F	G	H	K	L	M	N	P	Q	R		
13200005020	FV 20	20,5	7	62	45	45	5	75	57	57	56	75	10	33,5	25	46	320	9022501
13250005020	FV 25	25,3															292	
13300005020	FV 30	30,3															278	
13350005020	FV 35	35,4	9	75	60	60	5	100	76	76	73	100	12	43	32	57	587	9022801
13400005020	FV 40	40,4															581	



The fitting dimensions are largely adjusted to our profile technology BLOCAN®.

Solid Clamps

Base clamps



Plate without base clamp

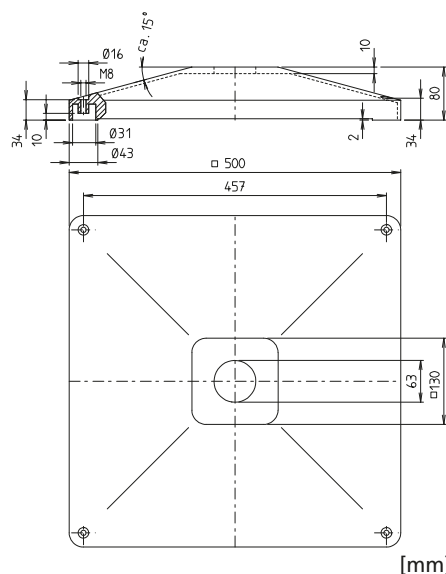

FP - Industrial design

Code No.	Type	m [g]
130000100_ _ _ _	FP	4440



Plate with base clamp Type FS

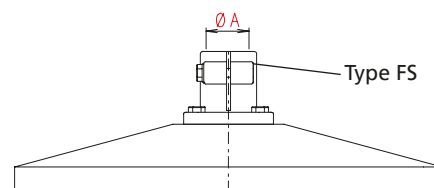

FP FS - Industrial design

Code No.	Type	A	m [g]
133200120_ _ _ _	FP FS 32	32,15	4946
134000120_ _ _ _	FP FS 40	40,15	4881
134800120_ _ _ _	FP FS 48	48,2	5141
135000120_ _ _ _	FP FS 50	50,2	5111



Plate with base clamp Type FRR

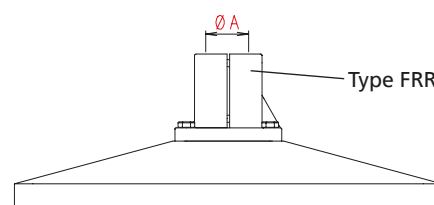

FP FRR - Industrial design

Code No.	Type	A	m [g]
134000130_ _ _ _	FP FRR 40	40,2	5037
134200130_ _ _ _	FP FRR 42	42,3	5854
134500130_ _ _ _	FP FRR 45	45,3	5799
134800130_ _ _ _	FP FRR 48	48,3	5783
135000130_ _ _ _	FP FRR 50	50,3	579



Plate with base clamp Type FV

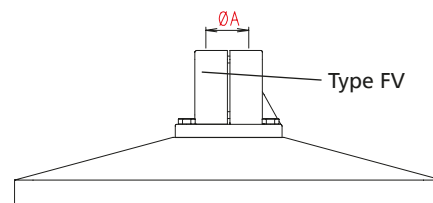

FP FV - Industrial design

[mm]

Code No.	Type	A	m [g]
133500150_	FP FV 35	35,4	5027
134000150_	FP FV 40	40,4	5010

Code No. +

Surface:

- 2 = nature
- A = RAL 7035, light grey
- B = RAL 7030, stone grey
- C = RAL 9005, jet black
- D = RAL 1021, yellow

Variants for clamping A:

- 0 = screws
- 1 = 1 lever
- 2 = 2 levers
- 3 = 3 levers
- 4 = 4 levers

Version:

- F = Bore hole

Filling:

- 0 = without filling dump moment 15 Nm

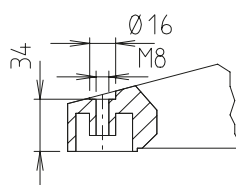

- 2 = Rubber foot

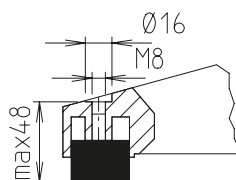

- 3 = Adjustable foot

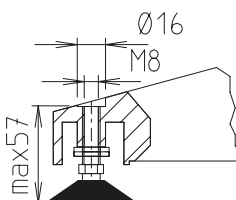

- 4 = Castor with brake

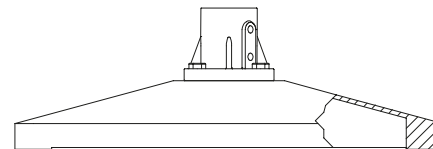
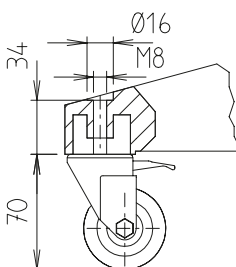

- X = hollow space with concrete plate (m = 14 kg) dump moment 65 Nm

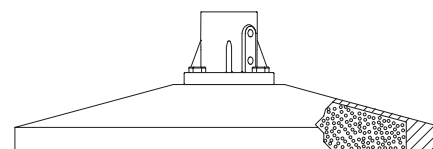

Order example:

Plate FP with base clamp FS 50, ground finish surface, equipped with screws, version with rubber foot, filled with concrete plate

135000120 2 0 2 X

Solid Clamps

Base clamps

Order instruction:

- Standard equipment premounted zinc plated screws
- Clamping levers have to be ordered separately Delivery unassembled See table last column and page 244

On request:

- Stainless steel screws
- Ball-polished
- Colour

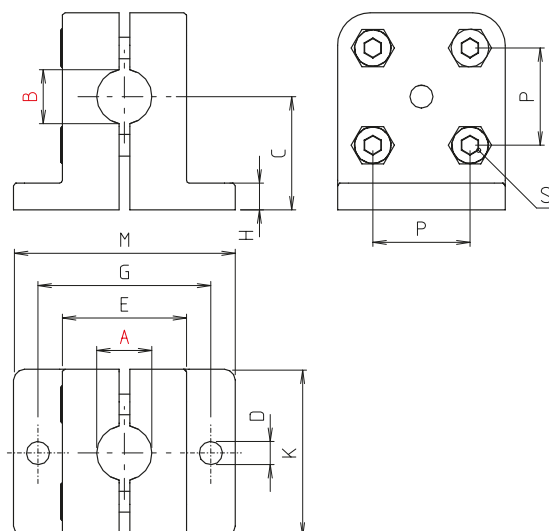

FFKR - Block form

[mm]

Code No.	Type	A	B	C	D	E	G	H	K	L	M	P	S	m [g]
291000020266	FFKR 10	10	10	21	4	23	32	5	31	36	41	18	M4x18	58

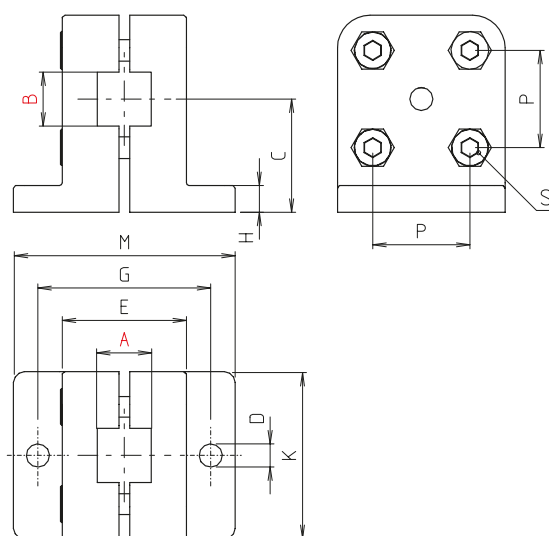

FFKV - Block form

[mm]

Code No.	Type	A	B	C	D	E	G	H	K	L	M	P	S	m [g]
291000030266	FFKV 10	10	10	21	4	23	32	5	31	36	41	18	M4x18	5

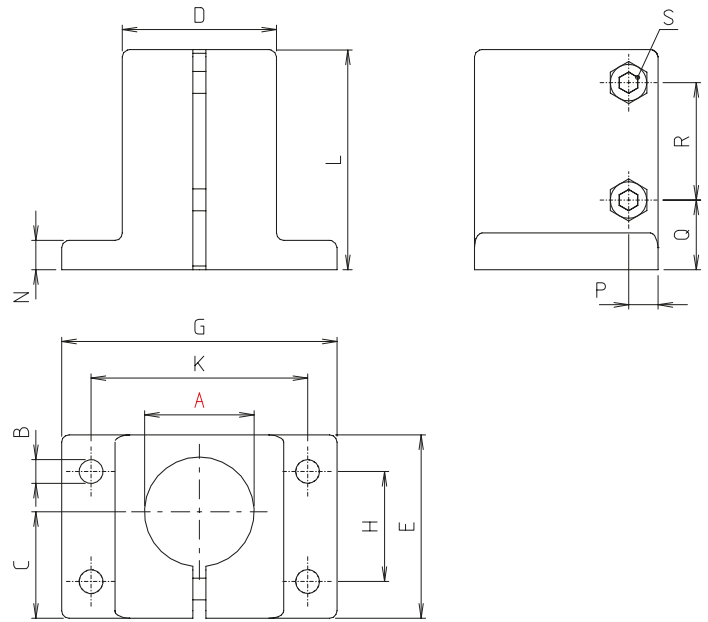

FSB - Block form

[mm]

Code No.	Type	A	B	C	D	E	G	H	K	L	N	P	Q	R	m [g]	Clamping lever S Code No.
2340000026	FSB 40	40,15	9	38	53	65	92	42	74	75	11	9,5	24	40	500	9022501

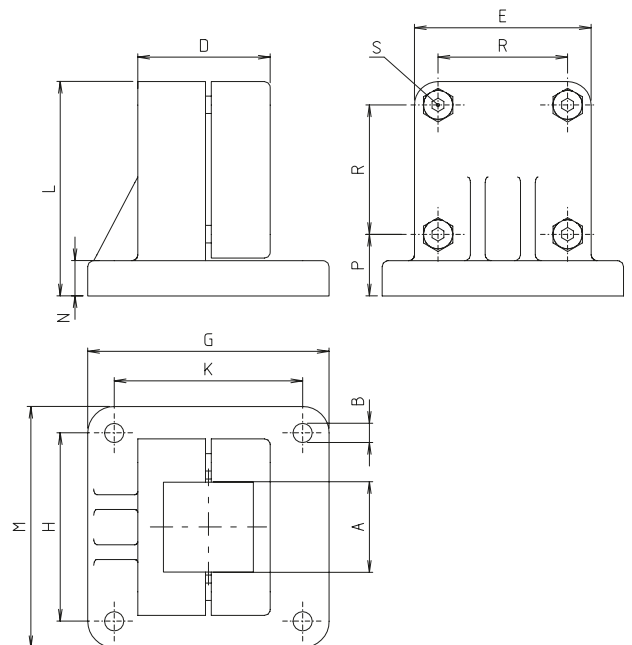

FV - Block form

[mm]

Code No.	Type	A	B	D	E	G	H	K	L	M	N	P	R	m [g]	Clamping lever S Code No.
23300005026	FV 30	30,3	6,5	48	60	82	64	64	73	82	12	21	44	403	9021401
23400005026	FV 40	40,4	6,5	62	70	95	76	76	85	95	14	23,5	53	600	9021601
23500005026	FV 50	50,5	9	79	86	125	98	98	102	125	15	26,5	65	1333	9022901
23800005026	FV 80*	80,7	11	122	130	240	100	190	150	130	20	35	100	3741	9024601

* With split flange plate

Solid Clamps

Base clamps

Order instruction:

- Standard equipment premounted zinc plated screws
- Clamping levers have to be ordered separately Delivery unassembled See table last column and page 244

On request:

- Stainless steel screws
- Ball-polished
- Colour

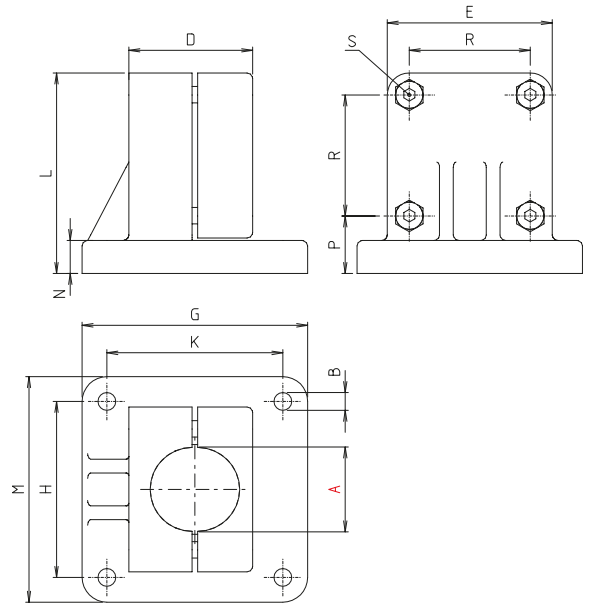

FRR - Block form

Code No.	Type	A	B	D	E	G	H	K	L	M	N	P	R	m [g]	Clamping lever S Code No.
23400003026	FRR 40	40,2	7	62	70	95	76	76	85	95	14	24	53	613	9021601
23420003026	FRR 42	42,3	9	79	86	125	98	98	102	125	15	27	65	1414	9022901
23450003026	FRR 45	45,3												1359	
23480003026	FRR 48	48,3												1343	
23500003026	FRR 50	50,3												1332	
23800003026	FRR 80*	80,7	11	120	130	240	100	190	150	130	20	35	100	3928	9024601

*With split flange plate

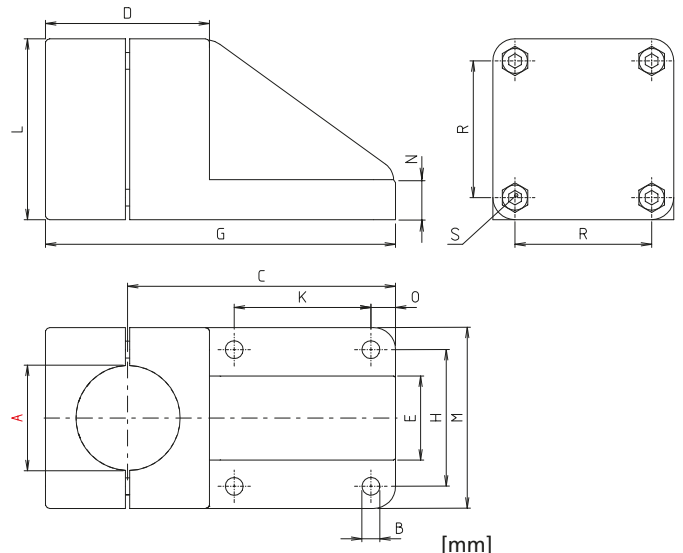

FRA - Block form

Code No.	Type	A	B	C	D	E	G	H	K	L	M	N	O	R	m [g]	Clamping lever S Code No.
23420002026	FRA 42	42,3	9	128	79	40	167	65	65	86	86	19	10,5	65	1198	9022901
23450002026	FRA 45	45,3													1217	
23480002026	FRA 48	48,3													1231	
23500002026	FRA 50	50,3													1205	
23600002026	FRA 60	60,4	9	147	90	46	192	78	78	100	100	22	11	78	1690	9021401

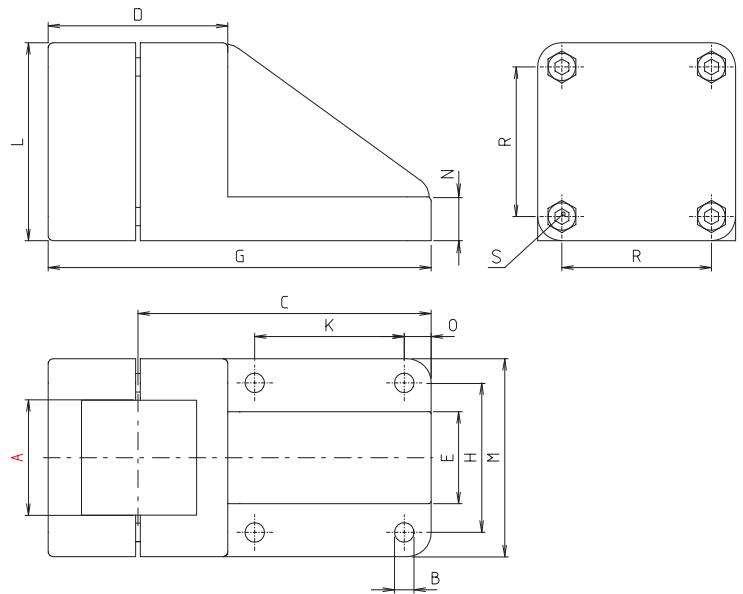
FVA - Block form

[mm]

Code No.	Type	A	B	C	D	E	G	H	K	L	M	N	O	R	m [g]	Clamping lever S Code No.
23500007026	FVA 50	50,5	9	127,5	79	40	167	65	65	86	86	19	10,5	65	1146	9022901
23600007026	FVA 60	60,6	9	147	90	46	192	78	78	100	100	22	11	78	1635	9023001

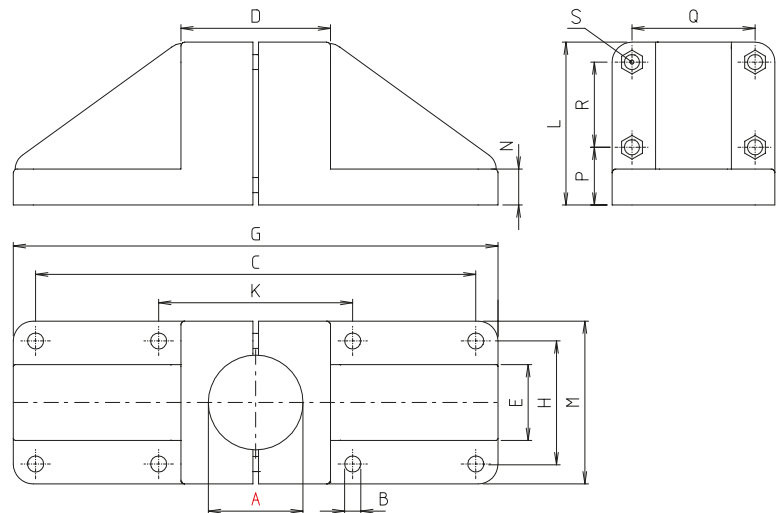
FRAA - Block form

[mm]

Code No.	Type	A	B	C	D	E	G	H	K	L	M	N	P	Q	R	m [g]	Clamping lever S Code No.
23420016026	FRAA 42	42,3	9	235	79	40	256	65	105	86	86	19	28,5	65	47	1570	9022901
23450016026	FRAA 45	45,3														1250	
23480016026	FRAA 48	48,3														1231	
23500016026	FRAA 50	50,3														1518	
23600016026	FRAA 60	60,4	9	272	90	46	294	78	116	100	100	22	30,5	78	58,5	2253	9023001

Solid Clamps

Base clamps

Order instruction:

- Standard equipment premounted zinc plated screws
- Clamping levers have to be ordered separately Delivery unassembled See table last column and page 244

On request:

- Stainless steel screws
- Ball-polished
- Colour

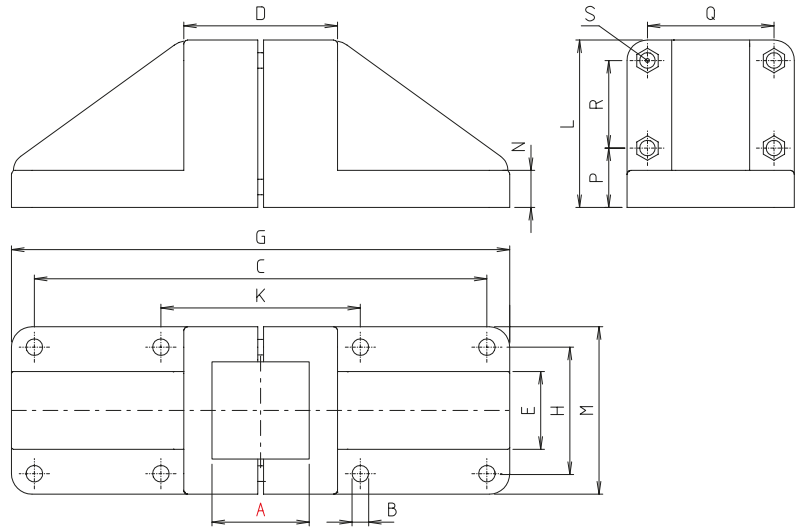

FVAA - Block form

[mm]

Code No.	Type	A	B	C	D	E	G	H	K	L	M	N	P	Q	R	m [g]	Clamping lever S Code No.
23500017026	FVAA 50	50,5	9	235	79	40	256	65	105	86	86	19	28,5	65	47	1479	9022901
23600017026	FVAA 60	60,6	9	272	90	46	294	78	116	100	100	22	30,5	78	58,5	2220	9023001

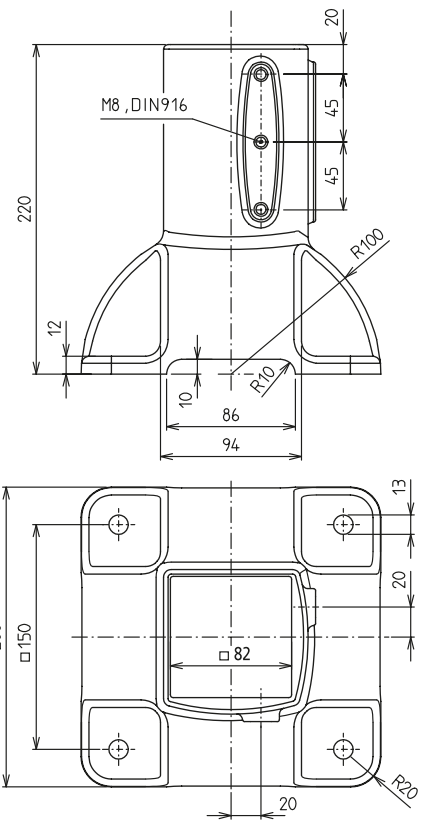

BAK-80 - Block form

[mm]

Code No.	Type	m [g]
4040501	BAK-80	1880



Solid Clamps

Base clamps



Plate without base clamp

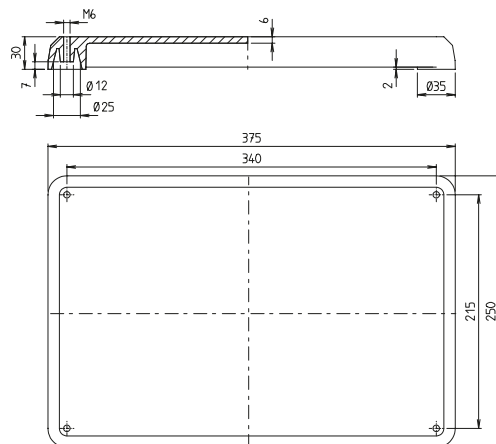

FP - Block form

[mm]

Code No.	Type	m [g]
230000100_ _ _ _	FP	1960



Plate with base clamp Type FS

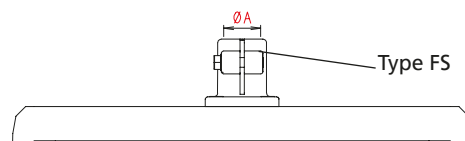

FP FS - Block form

[mm]

Code No.	Type	A	m [g]
232000120_ _ _ _	FP FS 20	20	2141
233000120_ _ _ _	FP FS 30	30,1	2400
233200120_ _ _ _	FP FS 32	32,15	2459
233500120_ _ _ _	FP FS 35	35,15	2434
234000120_ _ _ _	FP FS 40	40,15	2391

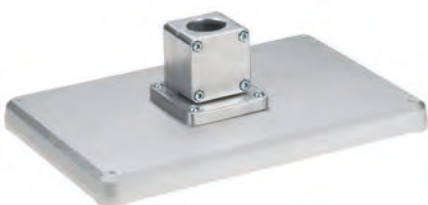
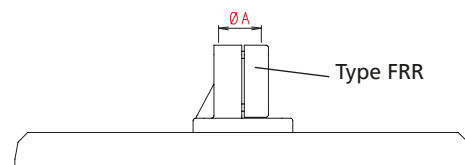

Plate with base clamp Type FRR



FP FRR - Block form

[mm]

Code No.	Type	A	m [g]
233000130_ _ _ _	FP FRR 30	30,15	2364
234000130_ _ _ _	FP FRR 40	40,2	2573



Plate with base clamp Type FV

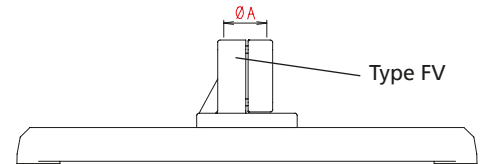

FP FV - Block form

[mm]

Code No.	Type	A	m [g]
233000150_ _ _ _	FP FV 30	30,3	2353
234000150_ _ _ _	FP FV 40	40,4	2550

Code No. +

Surface:

- 2 = nature
- A = RAL 7035, light grey
- B = RAL 7030, stone grey
- C = RAL 9005, jet black
- D = RAL 1021, yellow

Variants for clamping A:

- 6 = screws
- 1 = 1 lever
- 2 = 2 levers
- 3 = 3 levers
- 4 = 4 levers
- Not applicable: 230000100

Version:

F = Bore hole

2 = Rubber foot

3 = Adjustable foot

4 = Castor with brake

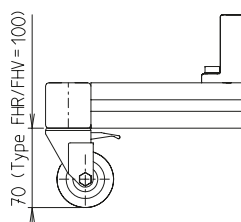
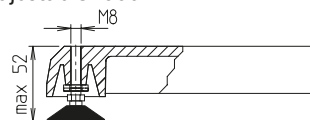
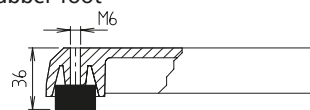
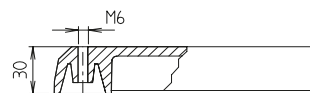

Filling:

0 = without filling dump moment 3 Nm

y = hollow space with steel plate
(m=4,6 kg)
dump moment 6 Nm

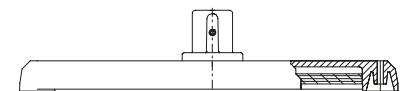
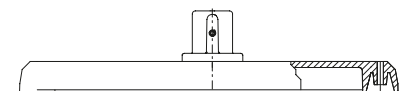

Order example:

Plate FP with base clamp FS 40,
ground finish surface,
equipped with screws,
version with rubber foot,
filled with steel plate

234000120 2 6 2 Y

Solid Clamps

Base clamps

Order instruction:

- Quad® with stainless steel screws
- Clamping levers have to be ordered separately Delivery unassembled See table last column and page

On request quad®:

- Black anodized



FS - quad®

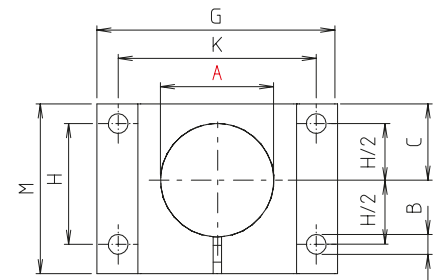
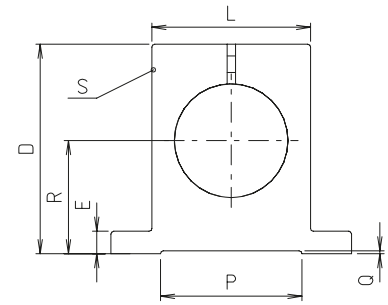

[mm]

Code No.	Type	A	B	C	D	E	G	H	K	L	M	P	Q	R	m [g]	Clamping lever S Code No.
53300000030	FS 30	30,1	7	21	58	6	70	28	56	42	49	35	1	30	182	9300101
53400000030	FS 40	40,1	7	28	74	8	85	40	70	56	62	50	1	40	369	9301401
53500000030	FS 50	50,2	9	35	92	10	110	50	90	70	77	60	1	50	738	9300401



FR - quad®

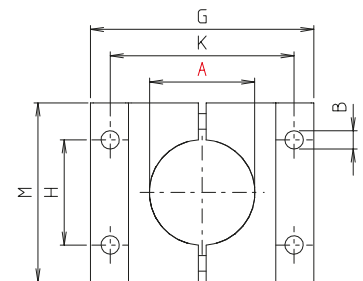
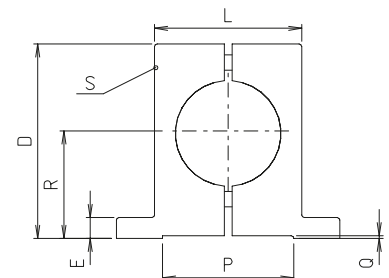

[mm]

Code No.	Type	A	B	D	E	G	H	K	L	M	P	Q	R	m [g]	Clamping lever S Code No.
53300009030	FR 30	30,1	7	58	6	70	28	56	42	56	35	1	30	223	9300101
53400009030	FR 40	40,2	7	74	8	85	40	70	56	68	50	1	40	431	9301401
53500009030	FR 50	50,3	9	92	10	110	50	90	70	84	60	1	50	857	9300401
53600009030	FR 60	60,2	9	112,5	12	137	80	120	97	105	71	2	60	-	9301101
53800009030	FR 80	80,6	11	142	16	156	80	135	112	126	80	2	80	2858	9300801



FV - quad®

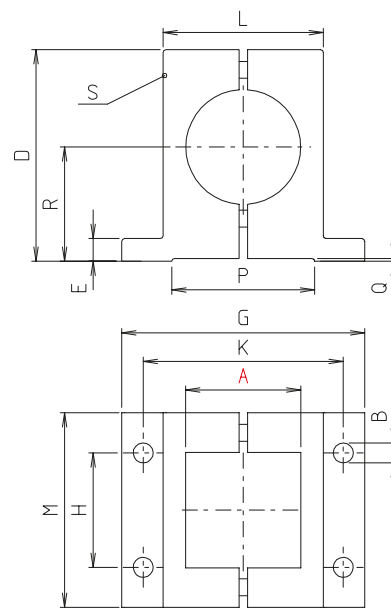

[mm]

Code No.	Type	A	B	D	E	G	H	K	L	M	P	Q	R	m [g]	Clamping lever S Code No.
53300005030	FV 30	30,2	7	58	6	70	28	56	42	56	35	1	30	197	9300101
53400005030	FV 40	40,3	7	73,5	8	85	40	70	56	68	50	1	40	375	9301401
53500005030	FV 50	50,4	9	92	10	110	50	90	70	84	60	1	50	750	9300401
53600005030	FV 60	60,4	9	112,5	12	137	80	120	97	105	71	2	60	-	9022801
53800005030	FV 80	80,4	11	142	16	156	80	135	112	126	80	2	80	2508	9300801

Solid Clamps

Insert clamps

Version:

- Insert clamps

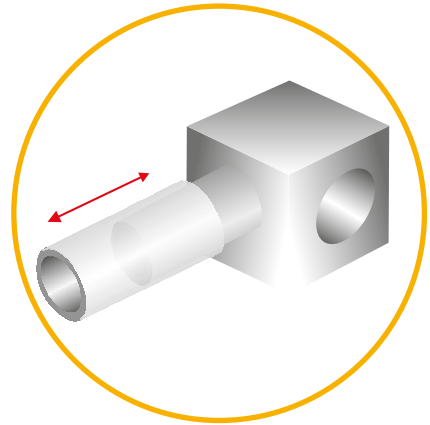

Single-piece elements

- For the quick and inexpensive installation



Industrial design

- Cast aluminium
- Great variety
- Single-piece elements



quad® elements

- Extruded aluminium
- Maximum torque loads
- High-quality anodized surface
- Single- and Multi-piece elements



Multi-piece elements

- Also suitable for subsequent assembly and expansion



Block form

- Cast aluminium
- Higher torque loads
- Plain surface
- Multi-piece elements

Loads insert clamps

Attention!

The data in the chart do not ensure a guarantee of quality or a warrant characteristic of our products. These are nonbinding standard values which might be not reached in individual cases due to the temperature or surface finish of the clamping profile.

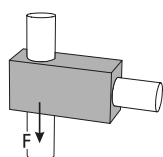

Adhesion force F [KN]

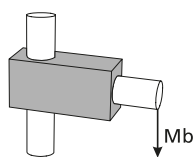

Bending moment Mb [Nm]

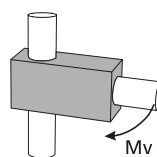

Twisting moment Mv [Nm]

Tightening torque of clamping screws:

M6: 10 Nm
M8: 25 Nm
M10: 50 Nm

Material data sheet available upon request.

Size	18			30			40			50			60			80		
	F	Mb	Mv	F	Mb	Mv	F	Mb	Mv	F	Mb	Mv	F	Mb	Mv	F	Mb	Mv
Industrial design																		
S	1,1	38	18	4	316	87	4,7	605	79	5	850	363	13	1500				

Size	18			30			40			50			60			80		
	F	Mb	Mv	F	Mb	Mv	F	Mb	Mv	F	Mb	Mv	F	Mb	Mv	F	Mb	Mv
Block form																		
SR													8,1	441	255			
SV													5,9	471	329			

Size	18			30			40			50			60			80		
	F	Mb	Mv	F	Mb	Mv	F	Mb	Mv	F	Mb	Mv	F	Mb	Mv	F	Mb	Mv
quad® elements																		
SW	2,7	182	58	3,3	352	68	5,8	994	147									
SK	2,2	188	51	1,5	291	59	6,9	994	167									
SFK	1,6	188	33	1,1	295	89	6,3	994	159									

Insert clamps

Right angle tube connector

Industrial design



Block form



quad® elements



Solid Clamps

Insert clamps

Order instruction:

- Standard equipment premounted zinc plated screws
- Clamping levers have to be ordered separately Delivery unassembled See table last column and page 244
- Stainless steel screws
- Ball-polished
- Colour



Type: S 18/18, S 25/25, S 30/30,
S 40/40, S 50/50, S 60/60

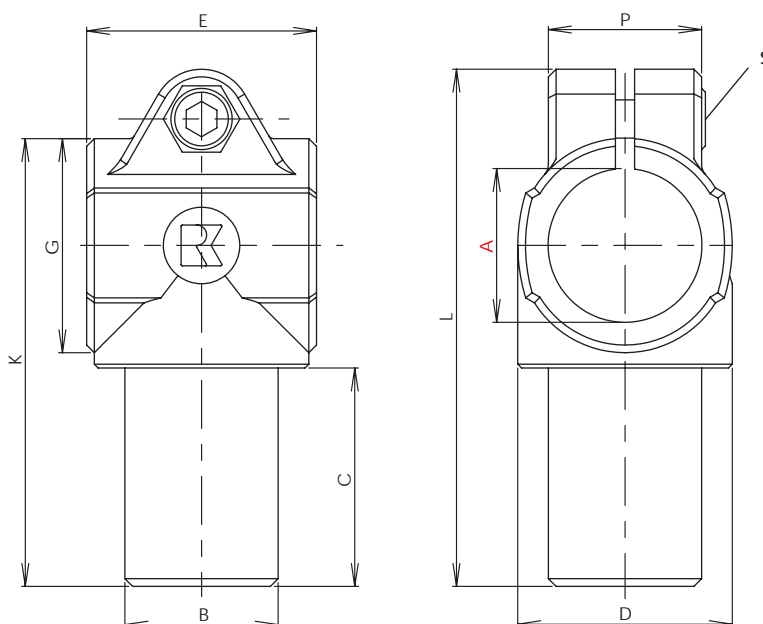

S - Industrial design

[mm]

Code No.	Type	A	B	C	D	E	G	K	L	P	m [g]	Clamping lever S Code No.
16181800020	S 18/18	18,1	18,1	33	26	32	26	62	72,5	21	56	90209
16252500020	S 25/25	25,1	25,1	42	40	45	40	87	100	33	188	9022201
	S 28/30*	*With adapter sleeve R28, see accessories page 245										
16303000020	S 30/30	30,1	30,1	42	40	45	40	87	100	33	174	9022201
16404000020	S 40/40	40,17	40,17	57	56	60	56	117	135	40	484	90250
16505000020	S 50/50	50,2	50					137	154	45	623	90251
16606000020	S 60/60	60,27	60,1	82	80	85	80	165	188	58	1128	9025301

Solid Clamps

Insert clamps

Order instruction:

- Standard equipment premounted zinc plated screws
- Clamping levers have to be ordered separately Delivery unassembled See table last column and page 244

On request:

- Stainless steel screws
- Ball-polished
- Colour

- Rope pulley: polyamide
- max. load 560 N

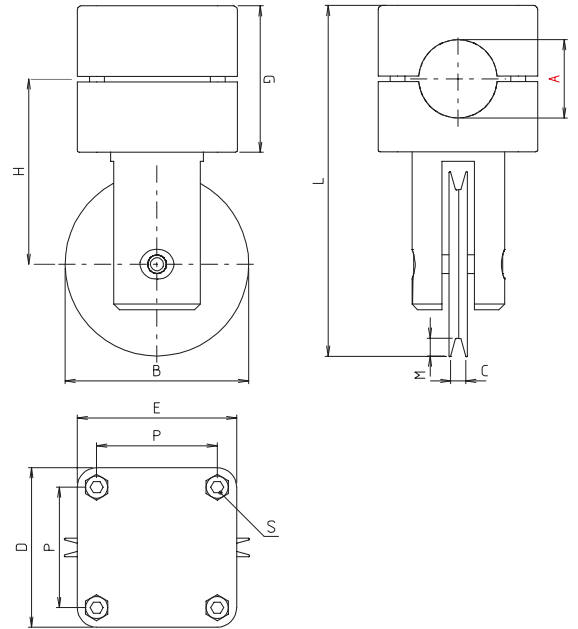

SRO - Block form

[mm]

Code No.	Type	A	B	C	D	E	G	H	L	M	P	m [g]	Clamping lever S Code No.
26420007026	SRO 42	42,3	100	8	86	86	79	100	189,5	10	65	1170	9022901
26450007026	SRO 45	45,3										1180	
26500007026	SRO 50	50,3										1200	

- Rope pulley: polyamide
- max. load 560 N

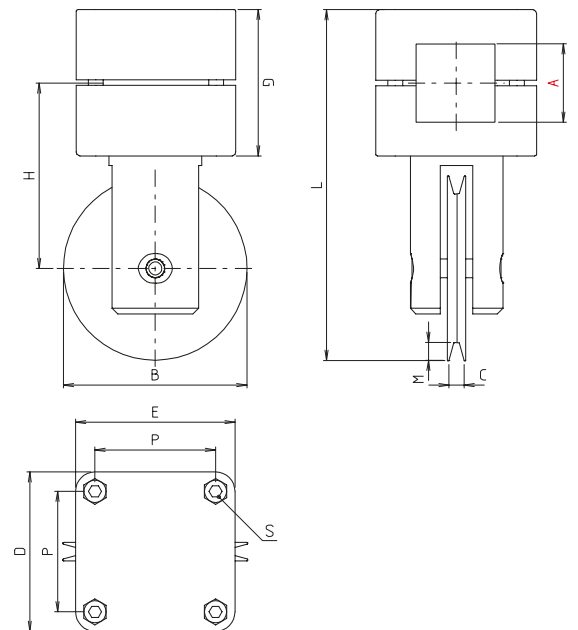
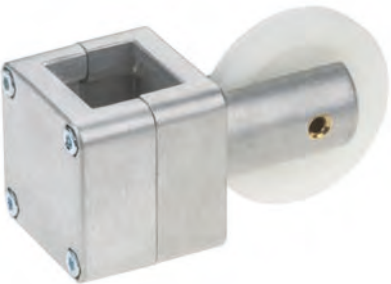

SVO - Block form

[mm]

Code No.	Type	A	B	C	D	E	G	H	L	M	P	m [g]	Clamping lever S Code No.
26500008026	SVO 50	50,5	100	8	86	86	79	100	189,5	10	65	1190	9022901

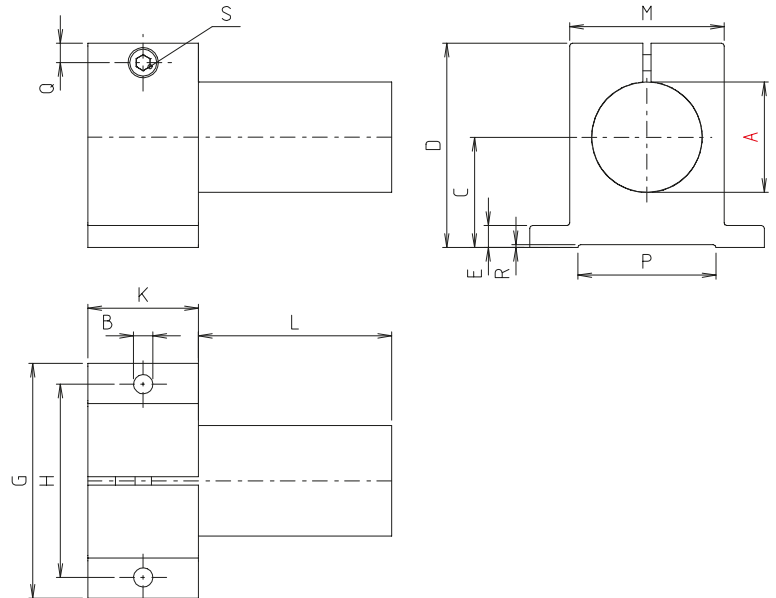

SFK - quad®

[mm]

Code No.	Type	A	B	C	D	E	G	H	K	L	M	P	Q	R	m [g]	Clamping lever S Code No.
56300015030	SFK 30	30	7	30	58	6	70	56	30	42	42	35	7	1	187	9300101
56400015030	SFK 40	40	7	40	74	8	85	70	40	56	56	50	7	1	427	9301401
56500015030	SFK 50	50	9	50	92	10	110	90	50	70	70	60	9	1	820	9300401

Solid Clamps

Sleeve clamps

Version:

- Sleeve clamps

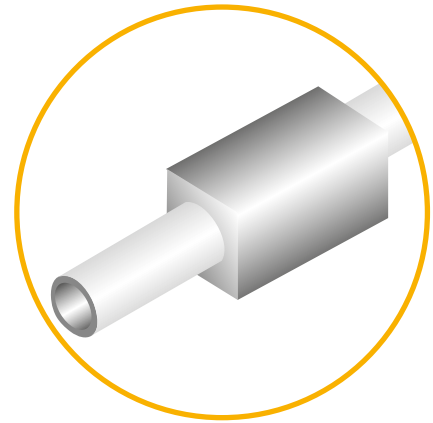

Single-piece elements

- For the quick and inexpensive installation



Industrial design

- Cast aluminium
- Great variety
- Single-piece elements



quad® elements

- Extruded aluminium
- Maximum torque loads
- High-quality anodized surface
- Single- and Multi-piece elements



Multi-piece elements

- Also suitable for subsequent assembly and expansion



quad® elements

- Extruded aluminium
- Maximum torque loads
- High-quality anodized surface
- Single- and Multi-piece elements

Loads sleeve clamps

Attention!

The data in the chart do not ensure a guarantee of quality or a warrant characteristic of our products. These are nonbinding standard values which might be not reached in individual cases due to the temperature or surface finish of the clamping profile.

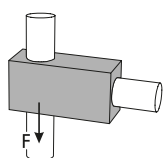

Adhesion force F [KN]

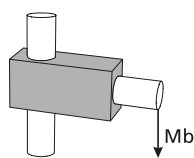

Bending moment Mb [Nm]

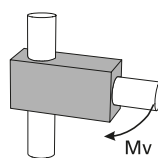

Twisting moment Mv [Nm]

Tightening torque of clamping screws:

M6: 10 Nm
M8: 25 Nm
M10: 50 Nm

Material data sheet available upon request.

Size	10			18			30			40			50			60		
Type	F	Mb	Mv	F	Mb	Mv	F	Mb	Mv	F	Mb	Mv	F	Mb	Mv	F	Mb	Mv
Industrial design																		
M							1,9	435		4,7	698		2,8	1000		15	2400	
MD							2,7	440		5	994		2,7	1000				
MH							4,7			10			9,4					

Size	30			40			50			80		
Type	F	Mb	Mv	F	Mb	Mv	F	Mb	Mv	F	Mb	Mv
quad® elements												
M	11,2	352		8,0	619		11,8	1267				
MD	6,2	324		7,8	612		8	1267				
MH	2,6			3,4			7,8					
MR	9	810		4,5	1024		12,6	1596				
MV	7,8	433		2,5	1074		7,4	1568				
MVR	3,6	491		1,9	975		7,4	1568				

Solid Clamps
Sleeve clamps

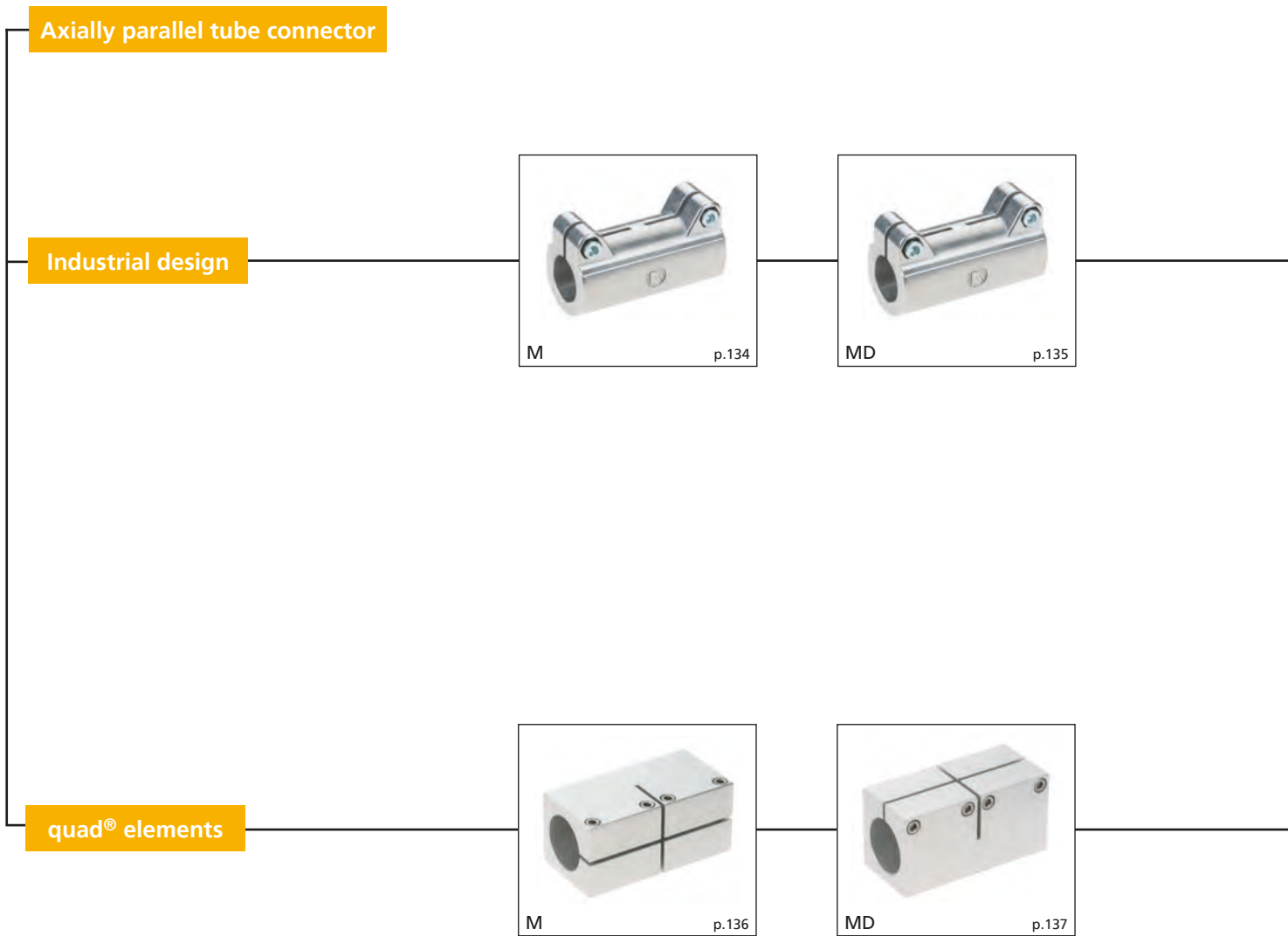

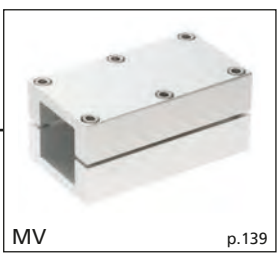
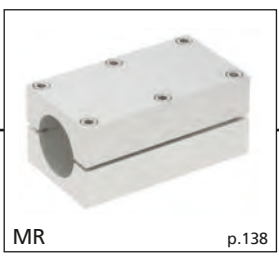
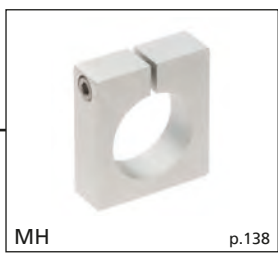

Solid Clamps

Sleeve clamps

Order instruction:

- Standard equipment premounted zinc plated screws
- Clamping levers have to be ordered separately Delivery unassbled See table last column and page 244

On request:

- Stainless steel screws
- Ball-polished
- Colour

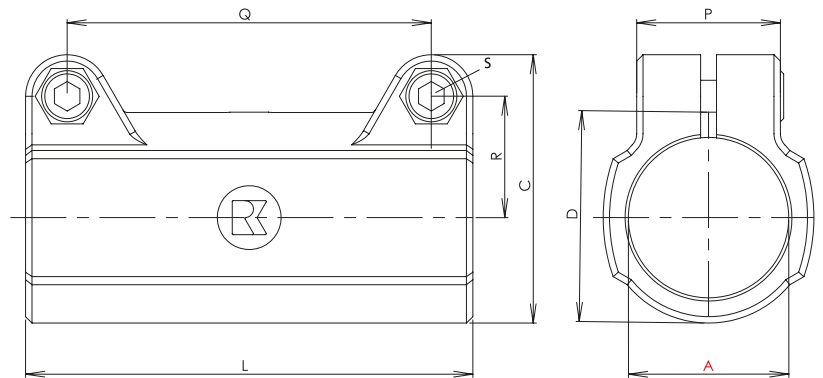

M - Industrial design

[mm]

Code No.	Type	A	C	D	L	P	Q	R	m [g]	Clamping lever S Code No.
142000000200	M 20	20,1	53	40	80	33	60	22,5	256	9022201
142500000200	M 25	25,1							220	
	M 28*	*With adapter sleeve R28, see accessories page 245								
143000000200	M 30	30,1	53	40	80	33	60	22,5	176	9022201
144000000200	M 40	40,17	73	56	120	40	94	32	501	90250
145000000200	M 50	50,22	84	66	140	45	114	38	650	90251
146000000200	M 60	60,27	103	80	150	58	118	47	1092	9025301

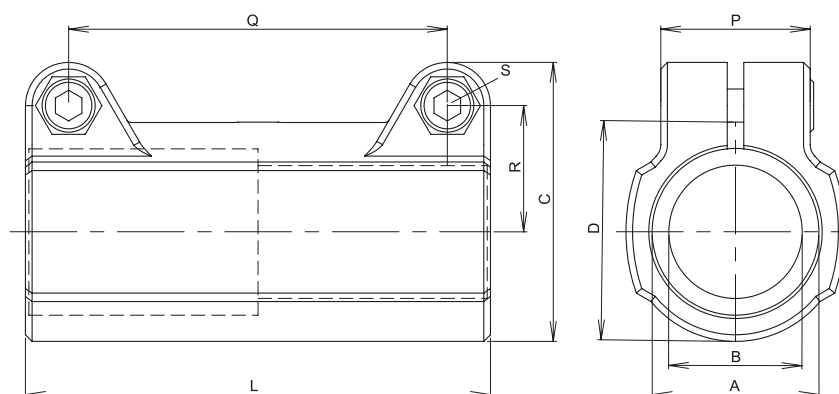

MD - Industrial design

[mm]

Code No.	Type	A	B	C	D	L	P	Q	R	m [g]	Clamping lever S Code No.
	MD 28x25*	*With adapter sleeve R28, see accessories page 245									
143025010200	MD 30x25	30,1	25,1	53	40	80	33	60	22,5	176	9022201
144032010200	MD 40x32	40,17	32,15	73	56	120	40	94	32	501	90250
145040010200	MD 50x40	50,22	40,17	84	66	140	45	114	38	822	90251
146048010200	MD 60x48	60,27	48,27	103	80	150	58	118	47	1288	9025301

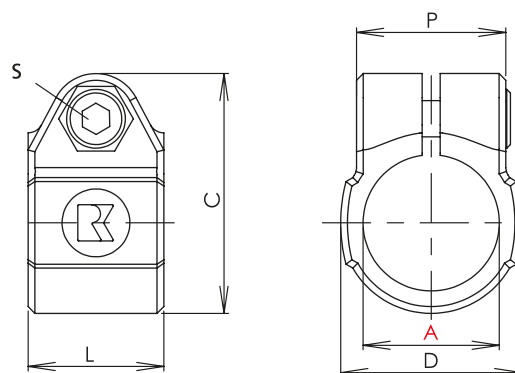

MH - Industrial design

[mm]

Code No.	Type	A	C	D	L	P	m [g]	Clamping lever S Code No.
14300002020	MH 30	30,1	53	40	30	33	80	9022201
14400002020	MH 40	40,15	73	56	40	40	200	90250
14500002020	MH 50	50,22	84	66	42	45	240	90251

Solid Clamps

Sleeve clamps

Order instruction:

- Block form zinc plated screws Quad® with stainless steel screws
- Clamping levers have to be ordered separately Delivery unassembled See table last column and page 244

On request:

- Stainless steel screws
- Ball-polished
- Colour

On request quad®:

- Black anodized

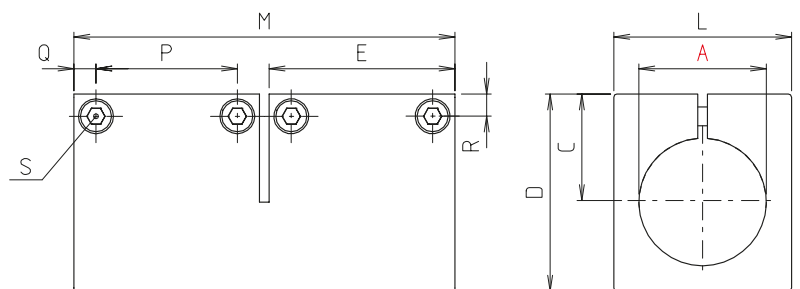

M - quad®

[mm]

Code No.	Type	A	C	D	E	L	M	P	Q	R	m [g]	Clamping lever S Code No.
543000000300	M 30	30,1	28	49	44	42	90	30	7	7	326	9300101
544000000300	M 40	40,1	34	62	58,5	56	120	44,5	7	7	703	9301401

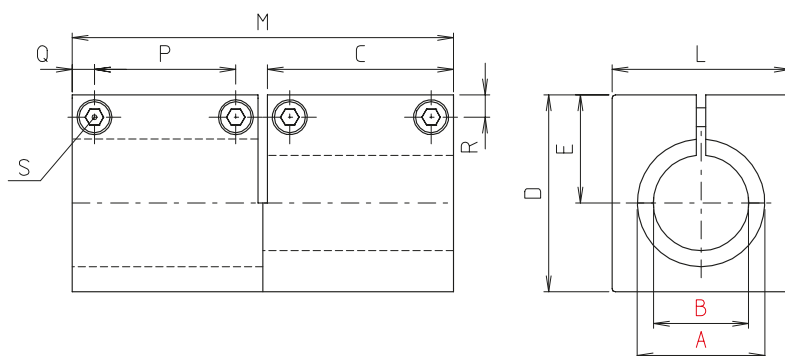

MD - quad®

[mm]

Code No.	Type	A	B	C	D	E	L	M	P	Q	R	m [g]	Clamping lever S Code No.
543020010300	MD 30x20	30,1	20,1	44	49	28	42	90	30	7	7	371	9300101
544030010300	MD 40x30	40,1	30,1	58,5	62	34	56	120	44,5	7	7	789	9301401



Roller block made from quad® clamp connectorp. Individually adjustable.

Solid Clamps

Sleeve clamps

Order instruction:

- Quad® with stainless steel screws
- Clamping levers have to be ordered separately Delivery unassembled See table last column and page

On request quad®:

- Black anodized

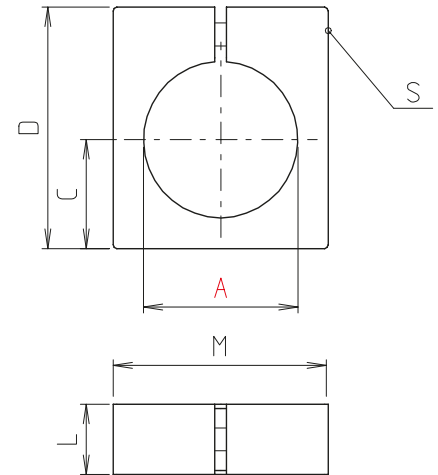

MH - quad®

Code No.	Type	A	C	D	L	M	R	m [g]	Clamping lever S Code No.
54300002030	MH 30	30,1	21	49	16	42	7	59	9300101
54400002030	MH 40	40,1	28	62	18	56	7	108	9301401

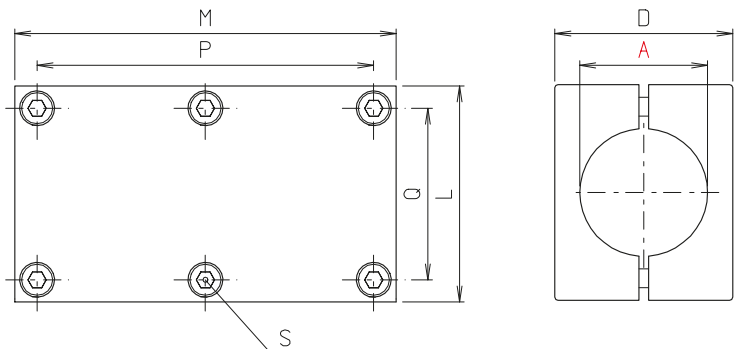

MR - quad®

Code No.	Type	A	D	L	M	P	Q	m [g]	Clamping lever S Code No.
54300003030	MR 30	30,1	42	56	90	76	42	404	9300101
54400003030	MR 40	40,2	56	68	120	106	54	800	9301401
54500003030	MR 50	50,3	70	85	140	120	67	1523	9300401
54600003030	MR 60	60,3	97	105	200	180	85	3943	9022801

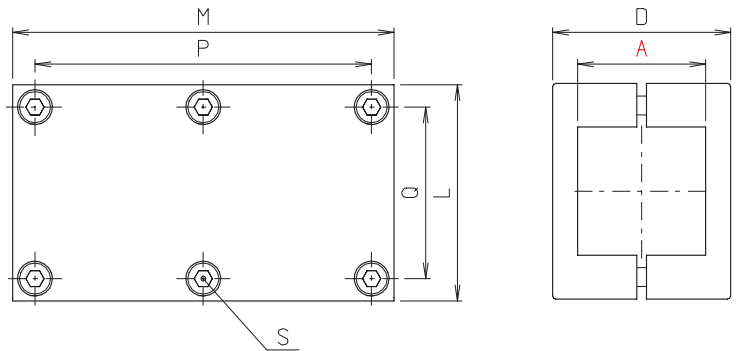

MV - quad®

[mm]

Code No.	Type	A	D	L	M	P	Q	m [g]	Clamping lever S Code No.
54300004030	MV 30	30,2	42	56	90	76	42	355	9300101
54400004030	MV 40	40,3	56	68	120	106	54	705	9301401
54500004030	MV 50	50,4	70	85	140	120	67	1302	9300401
54600004030	MV 60	60,4	97	105	200	180	85	3500	9022801

Solid Clamps

Parallel clamps

Version:

- Parallel clamps

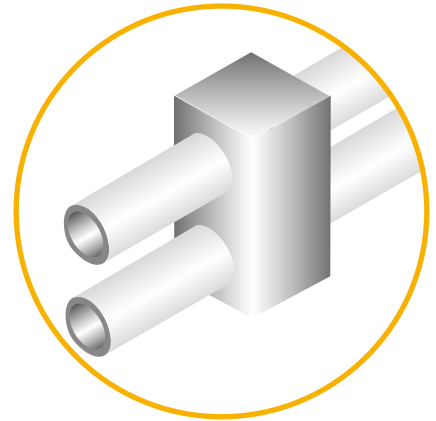

Single-piece elements

- For the quick and inexpensive installation



Industrial design

- Cast aluminium
- Great variety
- Single-piece elements



Block form

- Cast aluminium
- Higher torque loads
- Plain surface
- Multi-piece elements



Loads parallel clamps

Attention!

The data in the chart do not ensure a guarantee of quality or a warrant characteristic of our products. These are nonbinding standard values which might be not reached in individual cases due to the temperature or surface finish of the clamping profile.

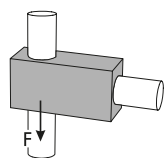

Adhesion force F [KN]

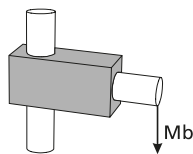

Bending moment Mb [Nm]

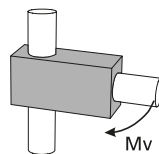

Twisting moment Mv [Nm]

Tightening torque of clamping screws:

- M6: 10 Nm
- M8: 25 Nm
- M10: 50 Nm

Material data sheet available upon request.

Size Type	10			18			30			40			50			60		
	F	Mb	Mv	F	Mb	Mv	F	Mb	Mv	F	Mb	Mv	F	Mb	Mv	F	Mb	Mv
Industrial design																		
P							2,7	100	40	12,2	700	317	8,9	1250	243			

Size Type	10			18			30			40			50			60		
	F	Mb	Mv	F	Mb	Mv	F	Mb	Mv	F	Mb	Mv	F	Mb	Mv	F	Mb	Mv
Block form																		
P				3,6	201	19	6	1210	97	11,5	1395	316	11,5	1250	181	13,5	1500	

Solid Clamps

Parallel clamps

Axially parallel tube connector

Industrial design

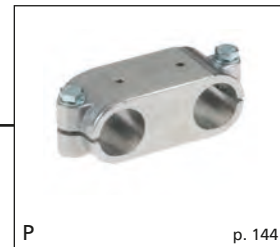
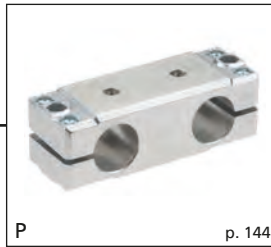

Block form



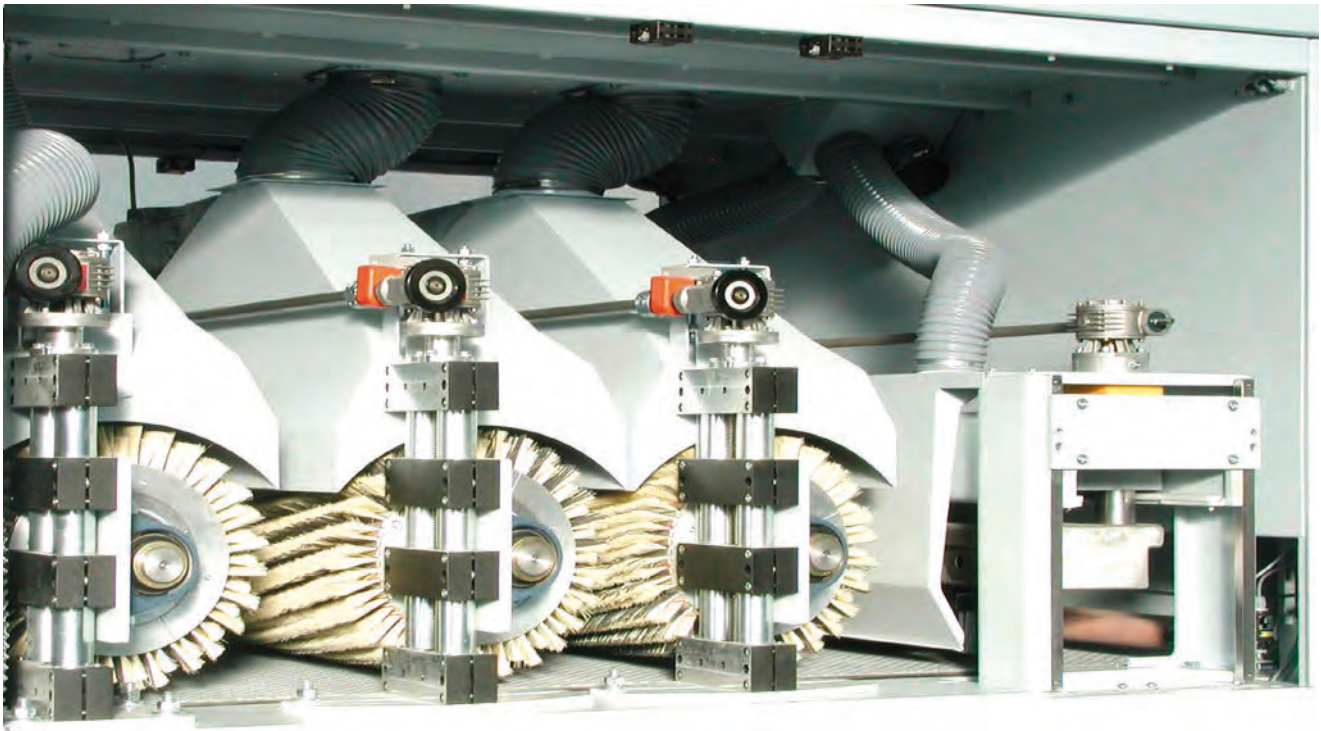

Height adjustment of a system for surface processing.

Solid Clamps

Parallel clamps

Order instruction:

- Standard equipment premounted zinc plated screws
- Clamping levers have to be ordered separately Delivery unassembled See table last column and page 244

On request:

- Stainless steel screws
- Ball-polished
- Colour

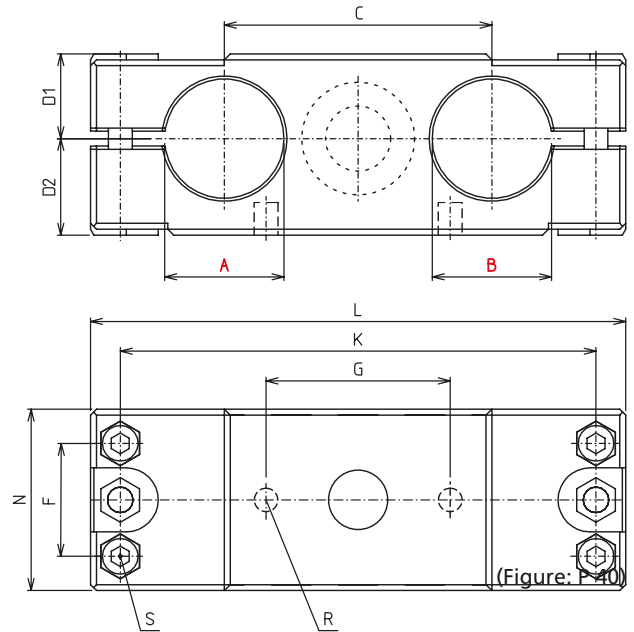

P - Industrial design

Code No.	Type	A	B	C	D1	D2	F	G	H	K	L	N	P	R	m [g]	Clamping lever S Code No.
151200000200	P 12	12,1	12,1	40	13,6	15	-	18	-	68	82	28,5	-	M5	140	9020101
151400000200	P 14	14,1	14,1											M5	134	
151600000200	P 16	16,1	16,1											M5	128	
154000000200	P 40	40,17	40,17	90	28,5	31,5	38	62	-	160	180	60	-	M8	1307	9022501

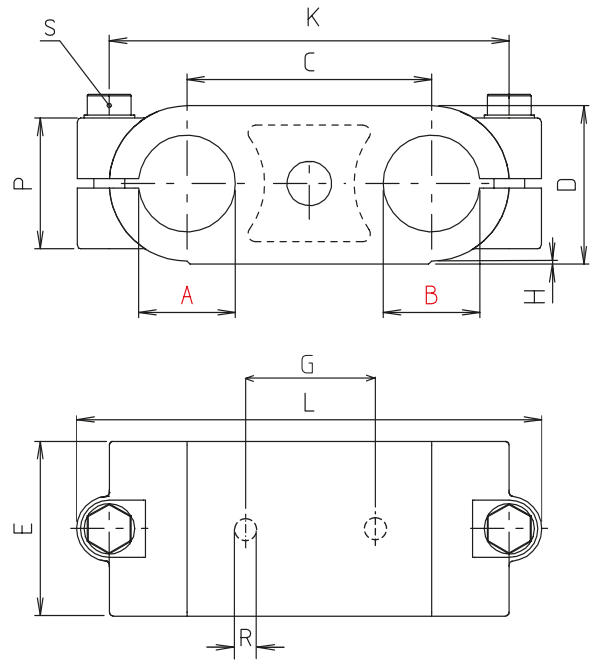

P - Industrial design

Code No.	Type	A	B	C	D	E	G	H	K	L	N	P	R	m [g]	Clamping lever S Code No.
152000000200	P 20	20,1	20,1	63	41	45	41	1	103	120	45	33	M5	367	9022401
152500000200	P 25	25,1	25,1											330	
153000000200	P 30	30,1	30,1											269	

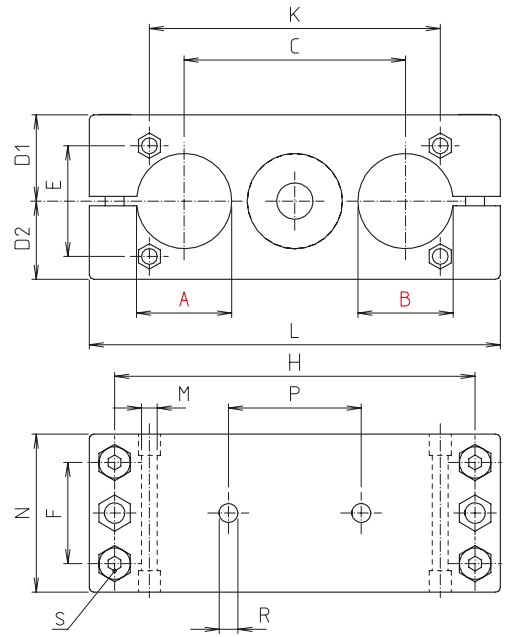

PB - Block form

[mm]

Code No.	Type	A	B	C	D1	D2	E	F	H	K	L	M	N	P	R	X	m [g]	Clamping lever S Code No.
253000000266	PB 30	30,1	30,1	70	27	25	35	32	114	92	130	5,3*	50	42	M6	28	622	9021501
254800000266	PB 48	48,2	48,2	100	36,5	35	50	50	206	150	206	8,5	72	62	M8	38	1799	9022801
255000000266	PB 50	50,2	50,2														1794	
256000000266	PB 60	60,3	60,25	130	44	42	60	56	216	185	240	8,5	80	74	M10	45	2727	-

* Counterbore 20 deep, without hexagonal.
The type 12–18 and 40 are no longer available. They are replaced by industrial design. See page 138

Solid Clamps

Flange clamps

Version:

- Flange clamps

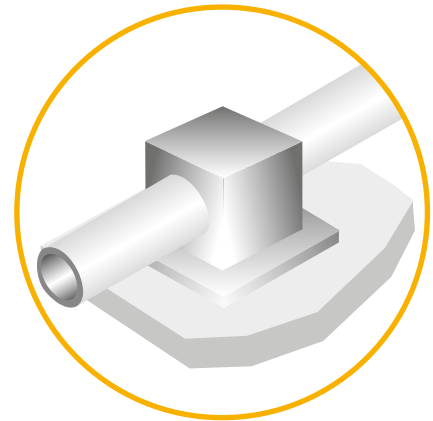

Single-piece elements

- For the quick and inexpensive installation



Industrial design

- Cast aluminium
- Great variety
- Single-piece elements



quad® elements

- Extruded aluminium
- Maximum torque loads
- High-quality anodized surface
- Single- and Multi-piece elements



Multi-piece elements

- Also suitable for subsequent assembly and expansion



quad® elements

- Extruded aluminium
- Maximum torque loads
- High-quality anodized surface
- Single- and Multi-piece elements



Block form

- Cast aluminium
- Higher torque loads
- Plain surface
- Multi-piece elements



Loads flange clamps

Attention!

The data in the chart do not ensure a guarantee of quality or a warrant characteristic of our products. These are nonbinding standard values which might be not reached in individual cases due to the temperature or surface finish of the clamping profile.

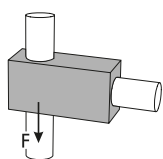

Adhesion force F [KN]

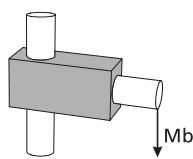

Bending moment Mb [Nm]

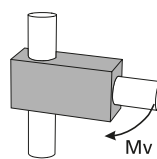

Twisting moment Mv [Nm]

Tightening torque of clamping screws:

M6: 10 Nm
M8: 25 Nm
M10: 50 Nm

Material data sheet available upon request.

Size Type	18			30			40			50			60			80		
	F	Mb	Mv	F	Mb	Mv	F	Mb	Mv	F	Mb	Mv	F	Mb	Mv	F	Mb	Mv
Industrial design																		
FK	1,1	128	21	4,9	200	95	8,9	504	254	11,6	750	1025	9,9	1393	253			
FKR				6,8	429	117	6	1190	152									
FKV				5,2	270	381	3	1247	955									
R				6,8			6											
V				5,2			3											
RH				4,0			6,1			4,9			5,1			6,3		
VH				1,7			2,5			3			4			10		

Size Type	18			30			40			50			60			80		
	F	Mb	Mv	F	Mb	Mv	F	Mb	Mv	F	Mb	Mv	F	Mb	Mv	F	Mb	Mv
Block form																		
FKR				4,3	438	96	2,5	450	700	8,2	1465	260	12,2	1456	255	10	2500	602
FKV				3,5	304	372	1,5	450	320	5,9	937	1250	7,8	1688	1203	20	2500	2250
R				4,3			5,7			9,4			12,2			10		
V				3,5			2,8			5,9			7,9			19		
RH				4,0			6,1			4,9			5,1			6,3		
VH				1,7			2,5			3			4			10		

Size Type	18			30			40			50			60			80		
	F	Mb	Mv	F	Mb	Mv	F	Mb	Mv	F	Mb	Mv	F	Mb	Mv	F	Mb	Mv
quad® elements																		
R				6,2			7,1			11,8						19,4		
RH				3,1			3,5			5,8						7,5		
V				5			7,4			7,5						20,1		
VH				1,9			4,2			2,6						7,7		
FK				2,5	484	59	4,9	750	89	6,3	1620	159						
FKH				2,7	96	48	3,2	102	62	5,6	230	86						
FKR				6,2	657	90	7,1	786	121	11,9	2146	272				19,4		950
FKRH				3,1	105	47	3,5	110	87	5,8	287	70				7,5		243
FKV				5	590	338	7,4	682	743	7,5	1904	1100				20,1		
FKVH				2,5	109	134	4,2	102	451	2,6	297	563				7,7		

Flange clamps

Axially parallel tube connector

Industrial design



Block form



quad® elements

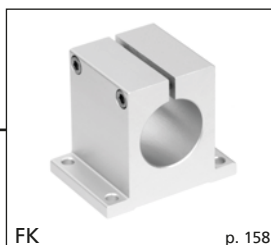

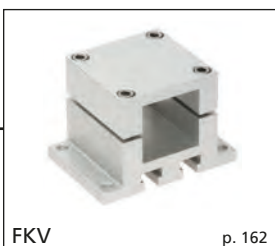
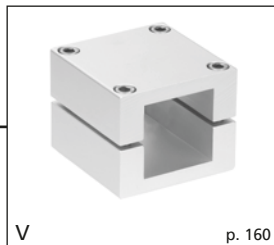
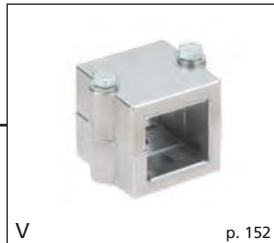
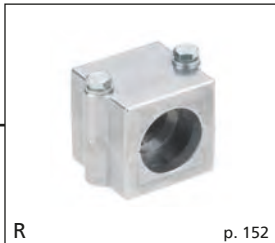

Solid Clamps

Flange clamps

Order instruction:

- Standard equipment premounted zinc plated screws
- Clamping levers have to be ordered separately Delivery unassembled See table last column and page 244

On request:

- Stainless steel screws
- Ball-polished
- Colour



FK 30-4 - 80
(4 drills, 20-60 with slotted hole)



FK 12-30
(2 central holes)

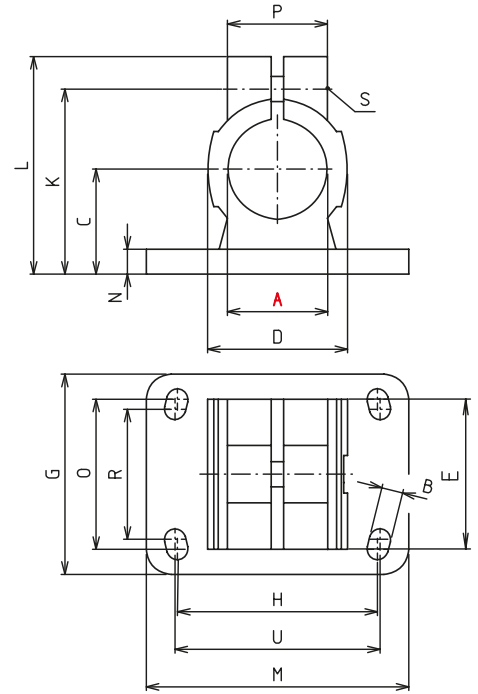

FK - Industrial design

Code No.	Type	A	B	C	D	E	G	H**	K	L	M	N	O*	P	R	U	m [g]	Clamping lever S Code No.		
12120000020	FK 12	12,1	6	18	25	35	35	38	32,5	41	50	5	-	23	-	40	67	90209		
12140000020	FK 14	14,1															64			
12150000020	FK 15	15,1															62			
12160000020	FK 16	16,1															60			
12180000020	FK 18	18,1															56			
12200000020	FK 20	20,1	7	30	40	40	55	53	53	63	78	7	-	33	-	60	202	9022201		
12200100020	FK 20-4	20,1															40		35	205
12250000020	FK 25	25,1															-		-	184
12250100020	FK 25-4	25,1															40		35	188
	FK 28*	*With adapter sleeve R28, see accessories page 245																		
12300000020	FK 30	30,1	7	30	40	40	55	53	53	63	78	7	-	33	-	60	162	9022201		
12300100020	FK 30-4	30,1															40		35	166
12300200020	FK30(32)	30,1	9	42	56	60	80	80	74	87	105	10	60	40	52	82	489	90250		
12320000020	FK 32	32,17															473			
12350000020	FK 35	35,15															449			
12400000020	FK 40	40,17															404			
12400200020	FK40(42)	40,17	11	50	66	65	90	98	85	98	128	14	62	45	60	100	703	90251		
12420000020	FK 42	42,22															682			
12480000020	FK 48	48,22															610			
12500000020	FK 50	50,22															585			
12600000020	FK 60	60,27	11	60	80	80	110	100	107	123	150	15	80	58	74	118	1048	9025301		
12800000020	FK 80	80,35	17,5	80	110	123	164,7	140	140	162,5	180	20	120	82	-	-	2930	9027001		

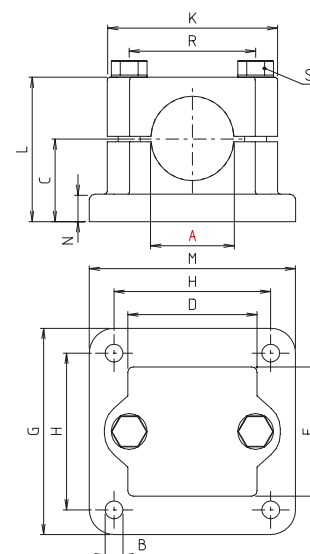

FKV - Industrial design

Code No.	Type	[mm]													m [g]	Clamping lever S Code No.
		A	B	C	D	E	G	H	K	L	M	N	R			
12200003020	FKR 20	20,2	7	30	45	45	75	57	62	52,5	75	10	46	314	9022601	
12250003020	FKR 25	25,2												301		
12300003020	FKR 30	30,2												285		
12350003020	FKR 35	35,2	9	40	60	60	100	76	75	70	100	10	57	569	9022901	
12400003020	FKR 40	40,2												545		

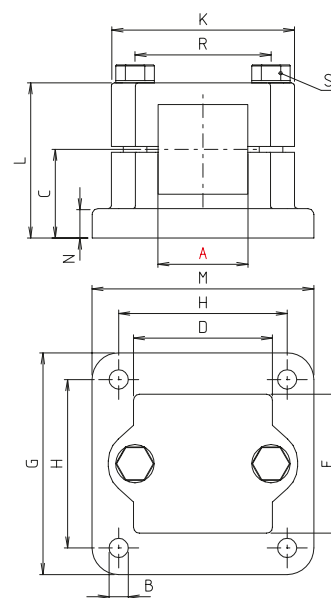
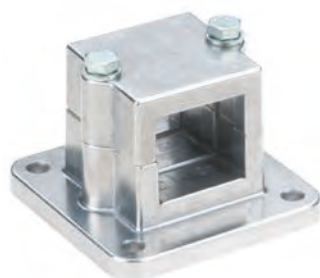

FKV - Industrial design

Code No.	Type	[mm]													m [g]	Clamping lever S Code No.
		A	B	C	D	E	G	H	K	L	M	N	R			
12200005020	FKV 20	20,2	7	30	45	45	75	57	62	52,5	75	10	46	302	9022601	
12250005020	FKV 25	25,3												292		
12300005020	FKV 30	30,3												273		
12350005020	FKV 35	35,4	9	40	60	60	100	76	75	70	100	10	57	555	9022901	
12400005020	FKV 40	40,4												530		

Solid Clamps

Flange clamps

Order instruction:

- Standard equipment premounted zinc plated screws
- Clamping levers have to be ordered separately Delivery unassembled See table last column and page 244

On request:

- Stainless steel screws
- Ball-polished
- Colour

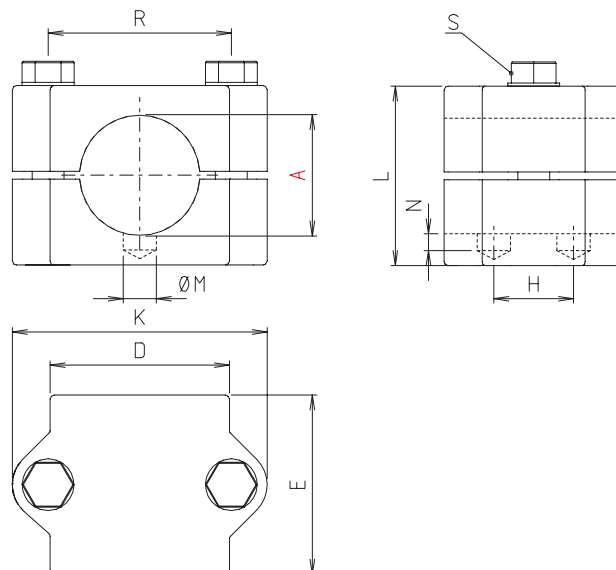

R - Industrial design

[mm]

Code No.	Type	A	D	E	H	K	L	M	N	R	m [g]	Clamping lever S Code No.
12200007020	R 20	20,1	45	45	20	62	45	10	3	46	211	9022501
12250007020	R 25	25,2									210	
12300007020	R 30	30,2									194	
12350007020	R 35	35,2	60	60	26	75	60	14	5,5	57	376	9022801
12400007020	R 40	40,2									360	

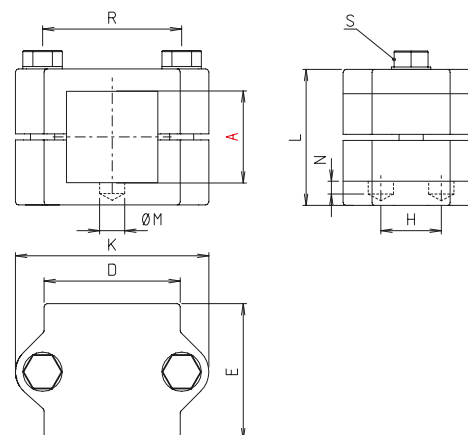

V - Industrial design

[mm]

Code No.	Type	A	D	E	H	K	L	M	N	R	m [g]	Clamping lever S Code No.
12200008020	V 20	20,3	45	45	20	62	45	10	3	46	202	9022501
12250008020	V 25	25,3									197	
12300008020	V 30	30,3									187	
12350008020	V 35	35,4	60	60	26	75	60	14	5,5	57	361	9022801
12400008020	V 40	40,4									334	

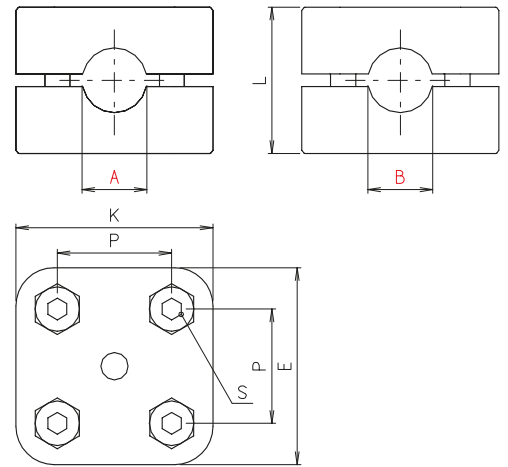

RRW - Block form

[mm]

Code No.	Type	A	B	E	K	L	P	S	m [g]
290800040266	RRW 8*	8	8	31	31	23	18	M4x18	47
291000040266	RRW 10	10	10						46

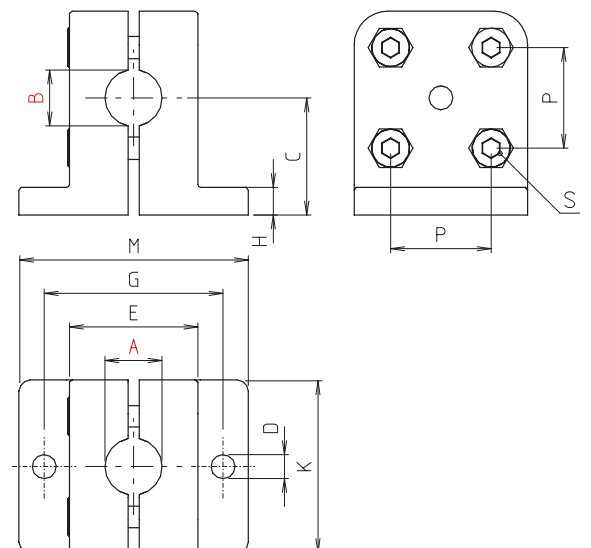

FFKR - Block form

[mm]

Code No.	Type	A	B	C	D	E	G	H	K	L	M	P	S	m [g]
290800020266	FFKR 8*	8	8	21	4	23	32	5	31	36	41	18	M4x18	62
291000020266	FFKR 10	10	10											58

* Ø 8 is achieved by means of a clamping sleeve

Solid Clamps

Flange clamps

Order instruction:

- Standard equipment premounted zinc plated screws
- Clamping levers have to be ordered separately Delivery unassembled See table last column and page 244

On request:

- Stainless steel screws
- Ball-polished
- Colour

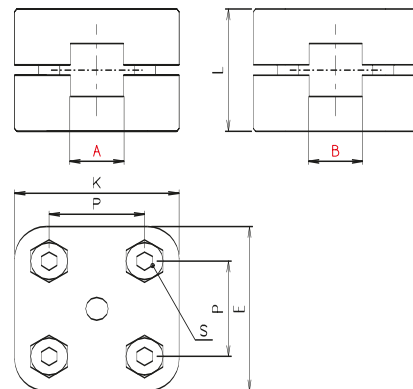

VVW - Block form

Code No.	Type	A	B	E	K	L	P	S	m [g]
291000050266	VVW 10	10	10	31	31	23	18	M4x18	42

[mm]

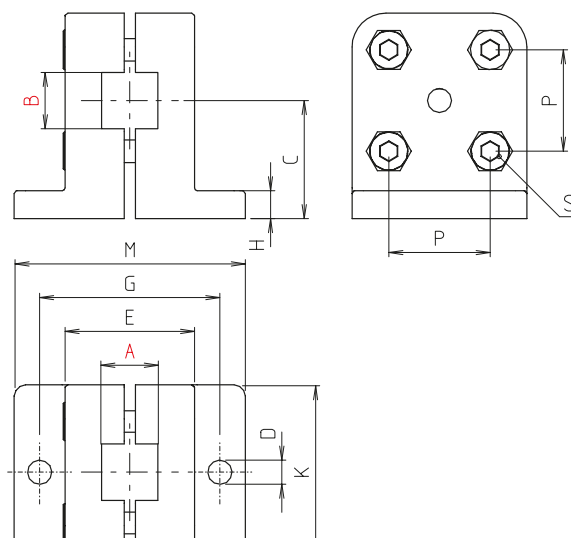

FFKV - Block form

Code No.	Type	A	B	C	D	E	G	H	K	L	M	P	S	m [g]
291000030266	FFKV 10	10	10	21	4	23	32	5	31	36	41	18	M4x18	60

[mm]

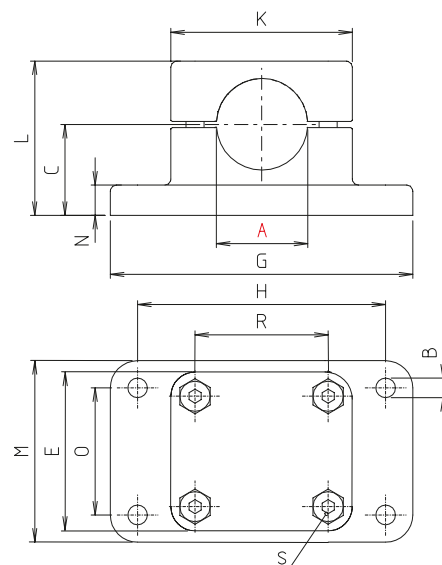

FKR - Block form

Code No.	Type	A	B	C	E	G	H	K	L	M	N	O	R	m [g]	Clamping lever S Code No.
22300003026	FKR 30	30,2	7	30	60	100	82	60	54	60	10	42	44	349	9021501
22350003026	FKR 35	35,4	7	40	70	110	92	70	73	71	12	52	53	552	
22400003026	FKR 40	40,2		80	90	100	88	78	76	74	14	54	55	521	
22480003026	FKR 48	48,3	9	50	86	125	98	86	90	125	12	98	65	1191	9023001
22500003026	FKR 50	50,3		90	100	110	100	90	90	125	12	98	65	1190	
22600003026	FKR 60	60,4	9	60	100	144	122	100	105	100	16	78	78	1489	9023101
22800003026	FKR 80	80,5	11	80	130	200	170	130	141	130	20	100	100	4050	9024601

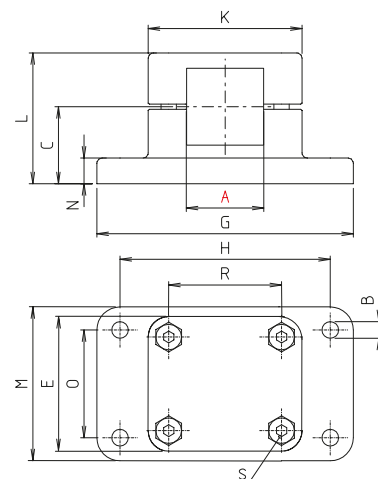

FKV - Block form

Code No.	Type	A	B	C	E	G	H	K	L	M	N	O	R	m [g]	Clamping lever S Code No.
22300005026	FKV 30	30,3	7	30	60	100	82	60	54	60	10	42	44	341	9021501
22400005026	FKV 40	40,4	7	42	70	110	92	70	73	70	12	52	53	511	9021701
22500005026	FKV 50	50,5	9	50	86	125	98	86	90	125	12	98	65	1124	9023001
22600005026	FKV 60	60,6	9	60	100	144	122	100	105	100	16	78	78	1428	9023101
22800005026	FKV 80	80,7	11	80	130	200	170	130	141	130	20	100	100	3878	9024601

Solid Clamps

Flange clamps

Order instruction:

- Standard equipment premounted zinc plated screws
- Clamping levers have to be ordered separately Delivery unassembled See table last column and page 244

On request:

- Stainless steel screws
- Ball-polished
- Colour

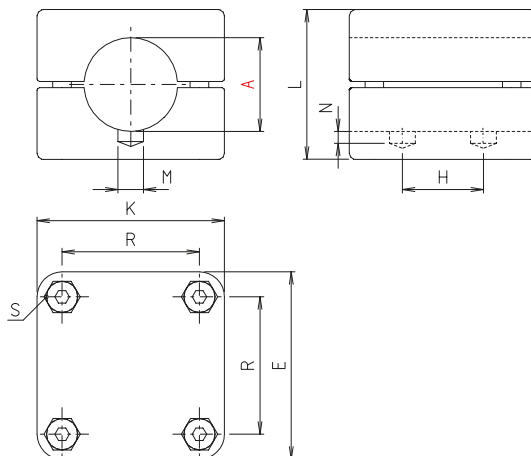

R - Block form

[mm]

Code No.	Type	A	E	H	K	L	M	N	R	m [g]	Clamping lever S Code No.
22300007026	R 30	30,1	60	26	60	48	11	5,5	44	256	9021401
22320007026	R 32	32,2	70	26	70	62	14	6	53	420	9021601
22350007026	R 35	35,2								410	
22400007026	R 40	40,2								395	
22420007026	R 42	42,3	86	50	86	79	14	8,5	65	914	9022901
22450007026	R 45	45,3								870	
22480007026	R 48	48,3								878	
22500007026	R 50	50,3								873	
22600007026	R 60	60,4	100	50	100	90	14	9	78	1136	9023001
22800007026	R 80	80,5	130	70	130	122	8,5	5,5	100	2560	9024601

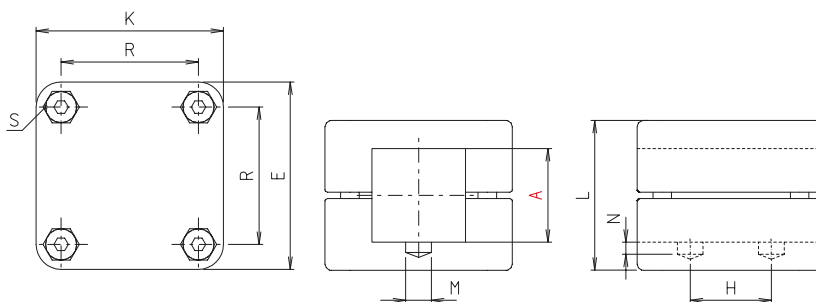

V - Block form

[mm]

Code No.	Type	A	E	H	K	L	M	N	R	m [g]	Clamping lever S Code No.
22300008026	V 30	30,3	60	26	60	48	11	5,5	44	249	9021401
22350008026	V 35	35,4	70	26	70	62	14	6	53	390	9021601
22400008026	V 40	40,4								404	
22500008026	V 50	50,5	86	50	86	79	14	8,5	65	811	9022901
22600008026	V 60	60,6	100	50	100	90	14	9	78	1064	9023001
22800008026	V 80	80,7	130	70	130	122	8,5	5,5	100	2380	9024601



RH - Block form

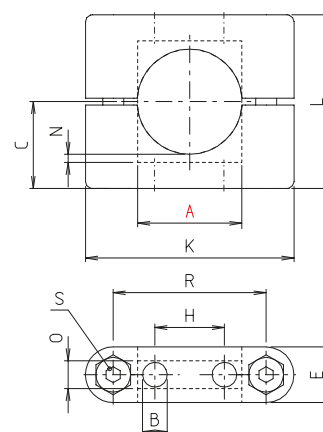

[mm]

Code No.	Type	A	B	C	E	H	K	L	N	O	R	m [g]	Clamping lever S Code No.
22200002026	RH 20	20,1	6	25	16	20	60	50	5	8,1	44	92	9021401
22250002026	RH 25	25,1										84	
22300002026	RH 30	30,1										72	
22350002026	RH 35	35,2	7	34	20	26	75	68	7	10,1	55	198	9022801
22400002026	RH 40	40,2										192	
22420002026	RH 42	42,3		40	20	26	86	79	7,5	10,1	65	256	9022901
22450002026	RH 45	45,3										242	
22480002026	RH 48	48,3										239	
22500002026	RH 50	50,3		45	22	26	100	90	6	10,1	78	236	9022301
22600002026	RH 60	60,4										318	
22800002026	RH 80	80,5	9	61	30	50	130	122	11	13,1	100	775	9024601



VH - Block form

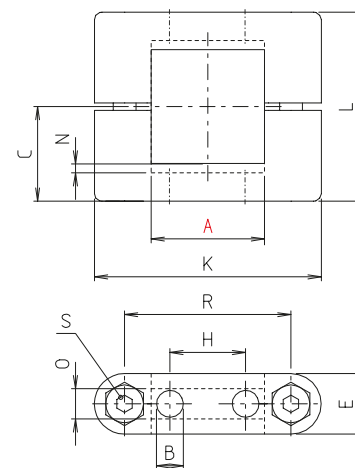

[mm]

Code No.	Type	A	B	C	E	H	K	L	N	O	R	m [g]	Clamping lever S Code No.							
22250004026	VH 25	25,3	6	25	16	20	60	50	5	8,1	44	85	9021401							
22300004026	VH 30	30,3										72								
22350004026	VH 35	35,4	7	34	20	26	75	68	7	10,1	55	184	9022801							
22400004026	VH 40	40,4										172								
22500004026	VH 50	50,5		40	20	26	86	79	7,5	10,1	65	217	9022901							
22600004026	VH 60	60,6										45		22	100	90	6	78	286	9023001
22800004026	VH 80	80,9																	9	

Solid Clamps

Flange clamps

Order instruction:

- Quad® with stainless steel screws
- Clamping levers have to be ordered separately Delivery unassembled See table last column and page

On request quad®:

- Black anodized

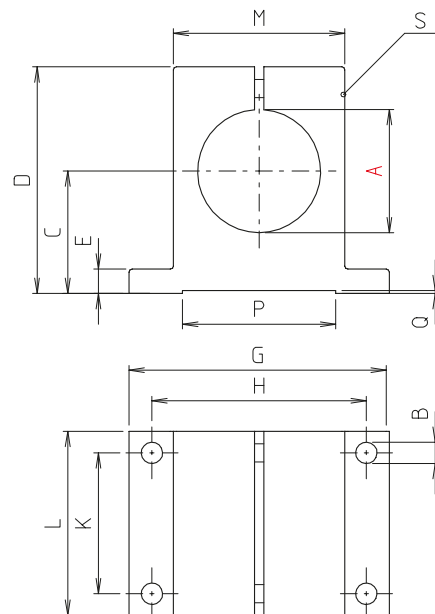

FK - quad®

[mm]

Code No.	Type	A	B	C	D	E	G	H	K	L	M	P	Q	m [g]	Clamping lever S Code No.
52300000030	FK 30	30,1	7	30	58	6	70	56	36	50	42	35	1	246	9300101
52400000030	FK 40	40,1	7	40	74	8	85	70	46	60	56	50	1	490	9301401
52500000030	FK 50	50,2	9	50	92	10	110	90	50	77	70	60	1	911	9300401

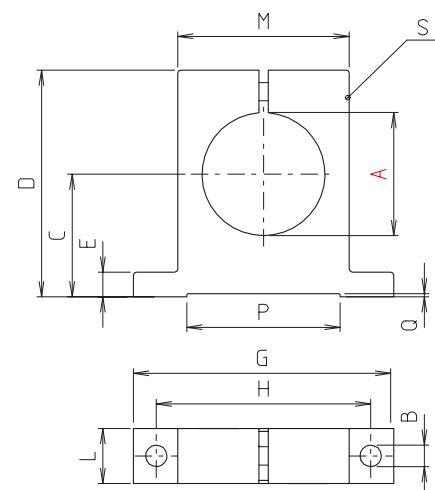

FKH - quad®

[mm]

Code No.	Type	A	B	C	D	E	G	H	L	M	P	Q	m [g]	Clamping lever S Code No.
52300011030	FKH 30	30,1	7	30	58	6	70	56	16	42	35	1	80	9300101
52400011030	FKH 40	40,1	7	40	74	8	85	70	18	56	50	1	147	9301401
52500011030	FKH 50	50,2	9	50	92	10	110	90	20	70	60	1	262	9300401

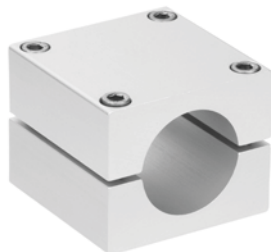

R - quad®

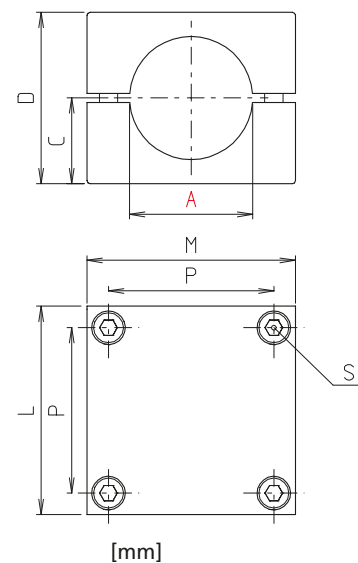

[mm]

Code No.	Type	A	C	D	L	M	P	m [g]	Clamping lever S Code No.
52300007030	R 30	30,1	21	42	56	56	42	252	9300101
52400007030	R 40	40,2	28	56	68	68	54	459	9301401
52500007030	R 50	50,3	35	70	85	85	67	927	9300401
52600007030	R 60	60,3	48,5	97	105	105	85	2083	9022801
52800007030	R 80	80,6	56	112	126	126	100	3000	9300801



RH - quad®

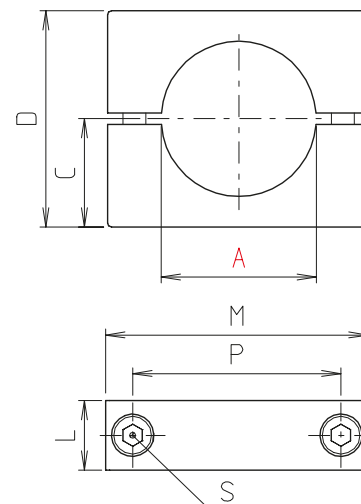

[mm]

Code No.	Type	A	C	D	L	M	P	m [g]	Clamping lever S Code No.
52300002030	RH 30	30,1	21	42	16	56	42	74	9300101
52400002030	RH 40	40,2	28	56	18	68	54	122	9301401
52500002030	RH 50	50,3	35	70	20	85	67	229	9300401
52600002030	RH 60	60,3	48,5	97	22	105	85	455	9022801
52800002030	RH 80	80,6	56	112	24	126	100	608	9300801

Solid Clamps

Flange clamps

Order instruction:

- Quad® with stainless steel screws
- Clamping levers have to be ordered separately Delivery unassembled See table last column and page

On request quad®:

- Black anodized

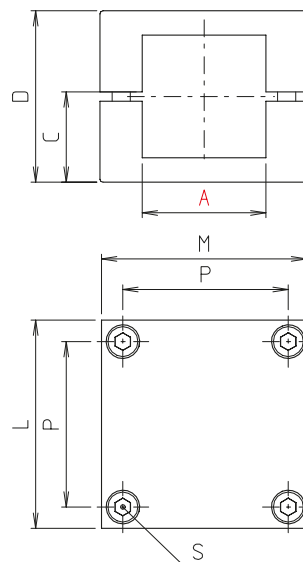

V - quad®

[mm]

Code No.	Type	A	C	D	L	M	P	m [g]	Clamping lever S Code No.
52300008030	V 30	30,2	21	42	56	56	42	220	9300101
52400008030	V 40	40,3	28	56	68	68	54	401	9301401
52500008030	V 50	50,4	35	70	85	85	67	785	9300401
52600008030	V 60	60,3	48,5	97	105	105	85	1851	9022801
52800008030	V 80	80,4	56	112	126	126	100	2540	9300801

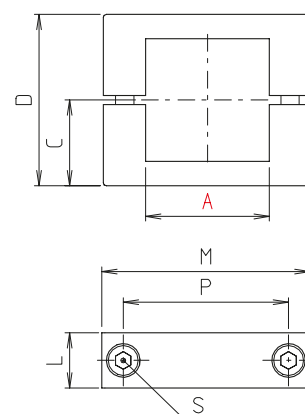

VH - quad®

[mm]

Code No.	Type	A	C	D	L	M	P	m [g]	Clamping lever S Code No.
52300004030	VH 30	30,2	21	42	16	56	42	65	9300101
52400004030	VH 40	40,3	28	56	18	68	54	109	9301401
52500004030	VH 50	50,4	35	70	20	85	67	197	9300401
52600004030	VH 60	60,4	48,5	97	22	105	85	406	9022801
52800004030	VH 80	80,4	56	112	24	126	100	522	9300801

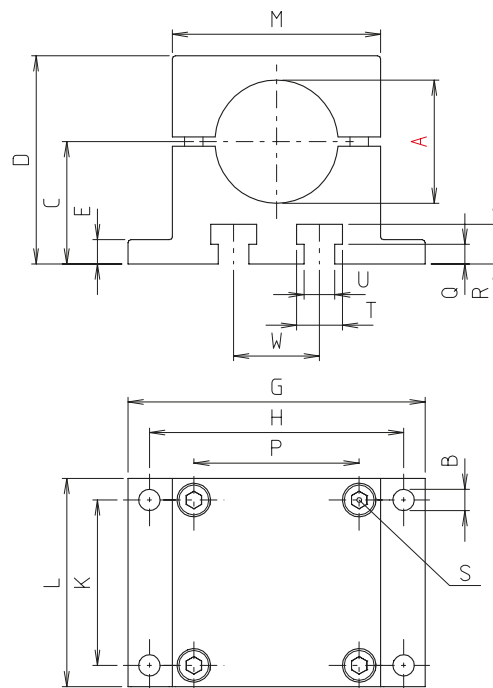
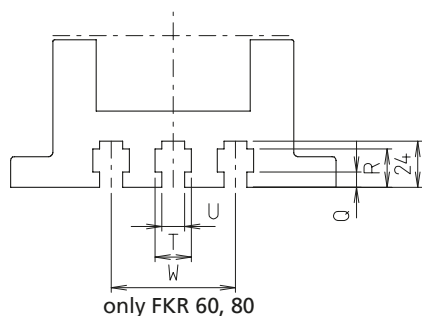

FKR - quad®

[mm]

Code No.	Type	A	B	C	D	E	G	H	K	L	M	P	Q	R	T	U	W	m [g]	Clamping lever S Code No.
52300003030	FKR 30	30,1	7	30	51	6	84	70	42	56	56	42	4,5	9	10	6	20	329	9300101
52400003030	FKR 40	40,2	7	40	68	8	97	83	54	68	68	54	6,5	13	15	10	28	586	9301401
52500003030	FKR 50	50,3	9	50	85	10	125	105	65	85	85	65	7	14	20	10	30	1204	9300401
52600003030	FKR 60	60,3	9	62,5	111	12	145	120	80	105	105	80	7	14	20	10	65	2456	9022801
52800003030	FKR 80	80,4	11	80	136	16	170	148	100	126	126	100	8	20	19	12	65	3876	9300801

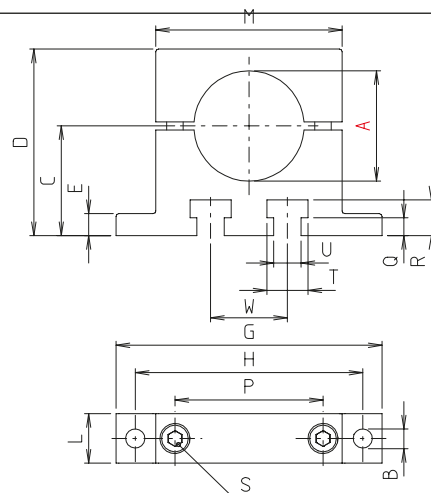
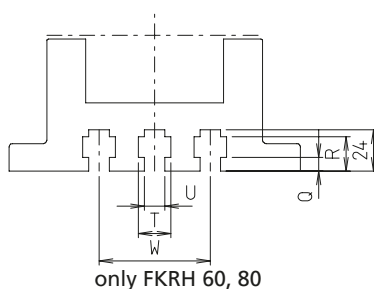

FKRH - quad®

[mm]

Code No.	Type	A	B	C	D	E	G	H	L	M	P	Q	R	T	U	W	m [g]	Clamping lever S Code No.
52300009030	FKRH 30	30,1	7	30	51	6	84	70	16	56	42	4,5	9	10	6	20	96	9300101
52400009030	FKRH 40	40,2	7	40	68	8	97	83	18	68	54	6,5	13	15	10	28	158	9301401
52500009030	FKRH 50	50,3	9	50	85	10	125	105	20	85	65	7	14	20	10	30	293	9300401
52600009030	FKRH 60	60,3	9	62,5	111	12	145	120	22	105	80	7	14	20	10	65	532	9022801
52800009030	FKRH 80	80,4	11	80	136	16	170	148	24	126	100	8	20	19	12	65	783	9300801

Solid Clamps

Flange clamps

Order instruction:

- Quad® with stainless steel screws
- Clamping levers have to be ordered separately Delivery unassembled See table last column and page

On request quad®:

- Black anodized

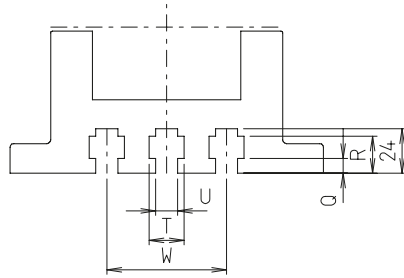

only FKV 60, 80

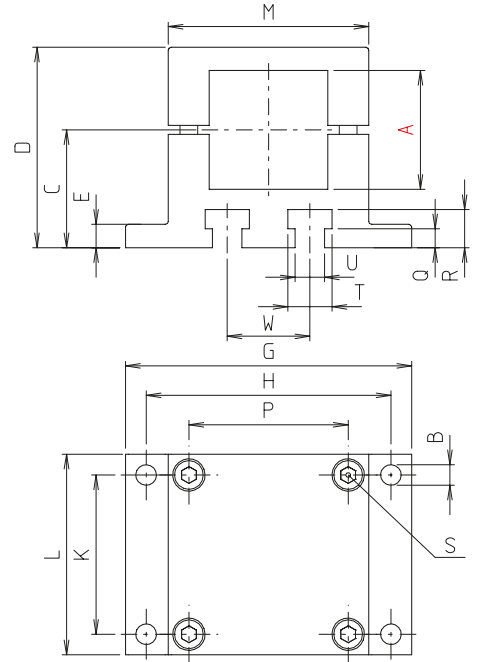

FKV - quad®

[mm]

Code No.	Type	A	B	C	D	E	G	H	K	L	M	P	Q	R	T	U	W	m [g]	Clamping lever S Code No.
52300005030	FKV 30	30,2	7	30	51	6	84	70	42	56	56	42	4,5	9	10	6	20	303	9300101
52400005030	FKV 40	40,3	7	40	68	8	97	83	54	68	68	54	6,5	13	15	10	28	525	9301401
52500005030	FKV 50	50,4	9	50	85	10	125	105	65	85	85	65	7	14	20	10	30	1065	9300401
52600005030	FKV 60	60,3	9	62,5	111	12	145	120	80	105	105	80	7	14	20	10	65	2224	9022801
52800005030	FKV 80	80,4	11	80	136	16	170	148	100	126	126	100	8	20	19	12	65	3440	9300801

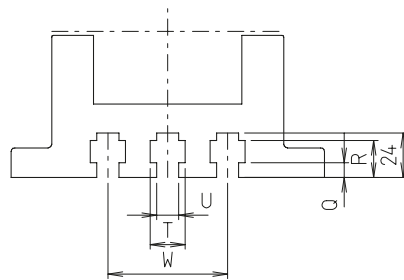

only FKVH 60, 80

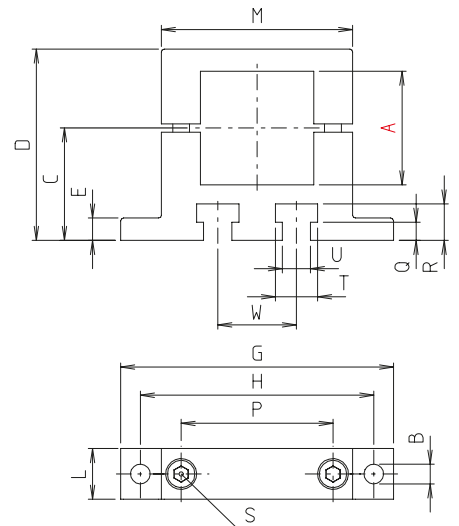

FKVH - quad®

[mm]

Code No.	Type	A	B	C	D	E	G	H	L	M	P	Q	R	T	U	W	m [g]	Clamping lever S Code No.
52300010030	FKVH 30	30,2	7	30	51	6	84	70	16	56	42	4,5	9	10	6	20	86	9300101
52400010030	FKVH 40	40,3	7	40	68	8	97	83	18	68	54	6,5	13	15	10	28	141	9301401
52500010030	FKVH 50	50,4	9	50	85	10	125	105	20	85	65	7	14	20	10	30	259	9300401
52600010030	FKVH 60	60,4	9	62,5	111	12	145	120	22	105	80	7	14	20	10	65	484	9022801
52800010030	FKVH 80	80,4	11	80	136	16	170	148	24	126	100	8	20	19	12	65	690	9300801

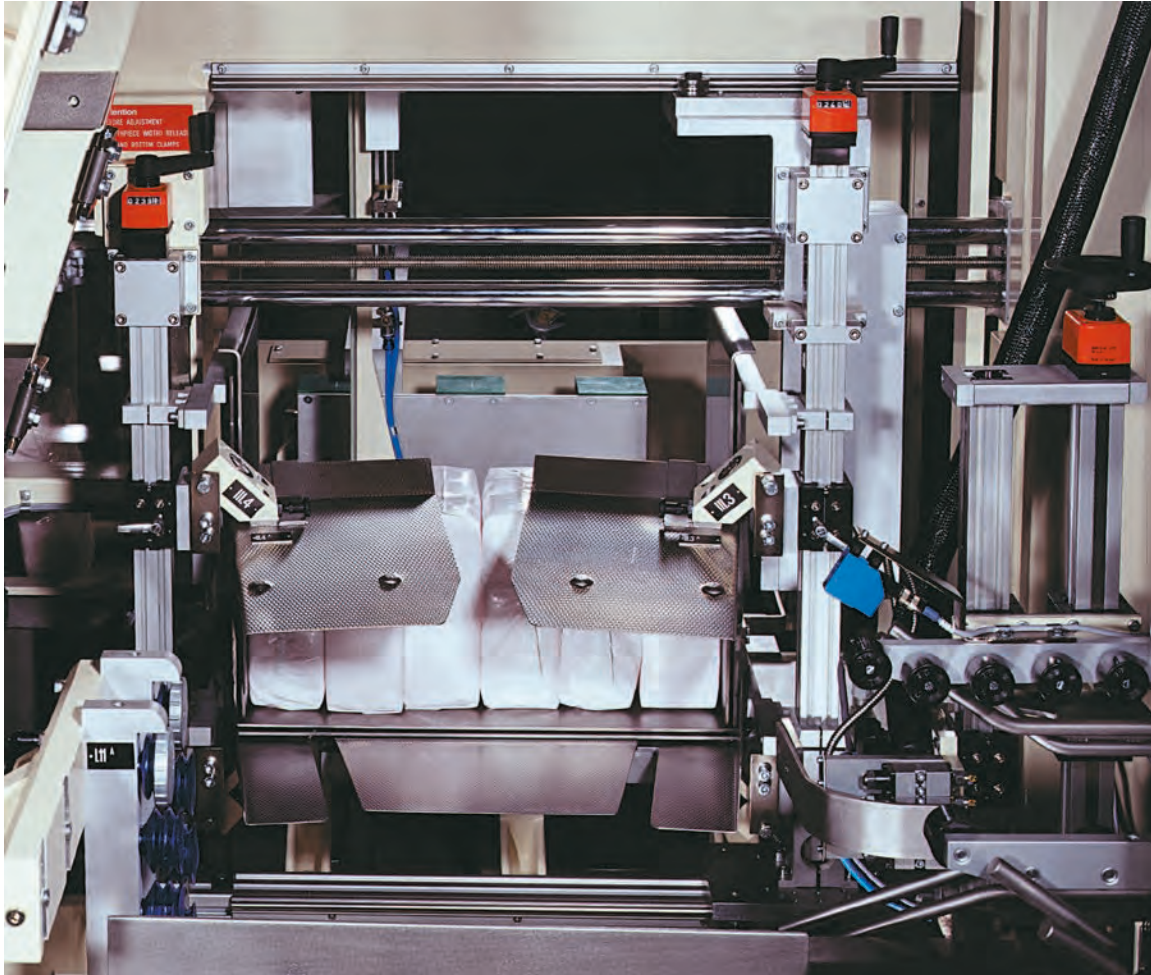

Simple fixation of linear units (for format adjustment) on a packaging machine.

Solid Clamps

Strap clamps

Version:

- Strap clamps

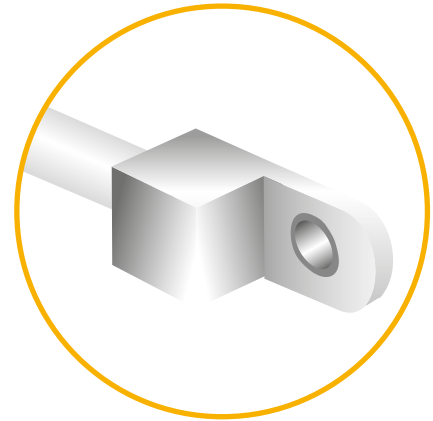

Single-piece elements

- For the quick and inexpensive installation



Industrial design

- Cast aluminium
- Great variety
- Single-piece elements



Multi-piece elements

- Also suitable for subsequent assembly and expansion



Block form

- Cast aluminium
- Higher torque loads
- Plain surface
- Multi-piece elements

Loads strap clamps

Attention!

The data in the chart do not ensure a guarantee of quality or a warrant characteristic of our products. These are nonbinding standard values which might be not reached in individual cases due to the temperature or surface finish of the clamping profile.

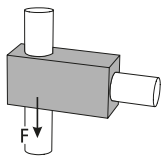

Adhesion force F [KN]

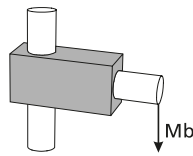

Bending moment Mb [Nm]

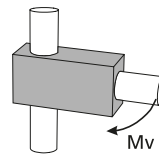

Twisting moment Mv [Nm]

Tightening torque of clamping screws:

M6: 10 Nm

M8: 25 Nm

M10: 50 Nm

Size	10			18			30			40			50			60		
	F	Mb	Mv	F	Mb	Mv	F	Mb	Mv	F	Mb	Mv	F	Mb	Mv	F	Mb	Mv
Industrial design																		
LW				2,7	38	15	6	133	85	5,8	264	138	12	274	358			
LP				3,6	28	9	4,9	91	94	6	267	181	12,1	332	387			
LQ				2,7	28	15	4,9	83	94	5,8	231	138	12,1	346	133			
LF					40	50		110	101		562	635		349	377			

Size	10			18			30			40			50			60		
	F	Mb	Mv	F	Mb	Mv	F	Mb	Mv	F	Mb	Mv	F	Mb	Mv	F	Mb	Mv
Block form																		
LWR										7,1	397	107						
LWV										3,2	333	287						
LPR										7,1	598	107						
LPV										3,2	405	438						
LQR										7,1	593	107						
LQV										3,2	738	653						
LF																		

Strap clamps

Hinge tube connector

Industrial design



Block form



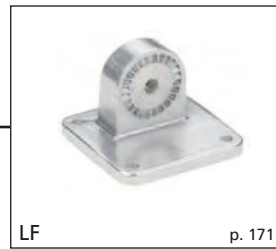

Solid Clamps

Strap clamps

Order instruction:

- Standard equipment premounted zinc plated screws
- Clamping levers have to be ordered separately Delivery unassembled See table last column and page 244

On request:

- Stainless steel screws
- Ball-polished
- Colour

serration: possibility of fixation by means of straight pins

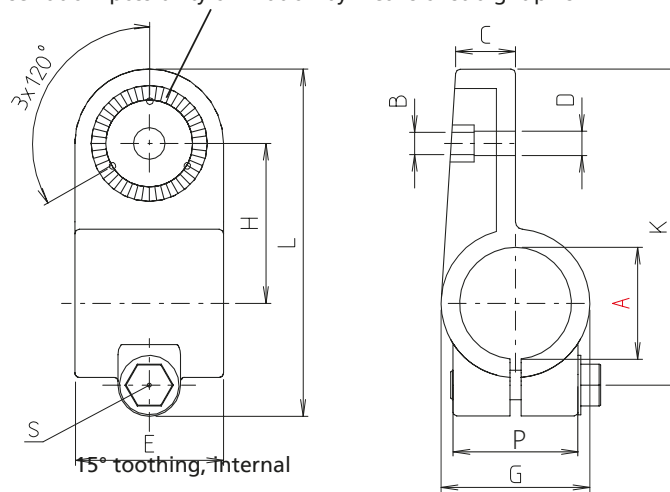

Type LW 12-18



Type LW 20-60

LW - Industrial design

[mm]

Code No.	Type	A	B	C	D	E	G	H	K	L	P	m [g]	Clamping lever S Code No.
17120000020	LW 12	12,1	M6	10,5	7,5	30	26	27	51,5	64,5	21	62	90210
17140000020	LW 14	14,1										59	
17160000020	LW 16	16,1										56	
17180000020	LW 18	18,1										52	
17200000020	LW 20	20	M8	16	9	40	40	43	85	93	33	169	9022401
17250000020	LW 25	25,1										150	
17300000020	LW 30	30,1										131	
17320000020	LW 32	32,2	M10	22	11	56	56	60	116	128	48	428	9024301
17400000020	LW 40	40,2										366	
17420000020	LW 42	42,2	M10	25	11	66	66	70	136	148	58	586	9024401
17450000020	LW 45	45,2										547	
17480000020	LW 48	48,2										519	
17500000020	LW 50	50,2										488	
17600000020	LW 60	60,2	M12	30	13,5	80	80	85	165	178	68	820	9024401

serration: possibility of fixation by means of straight pins

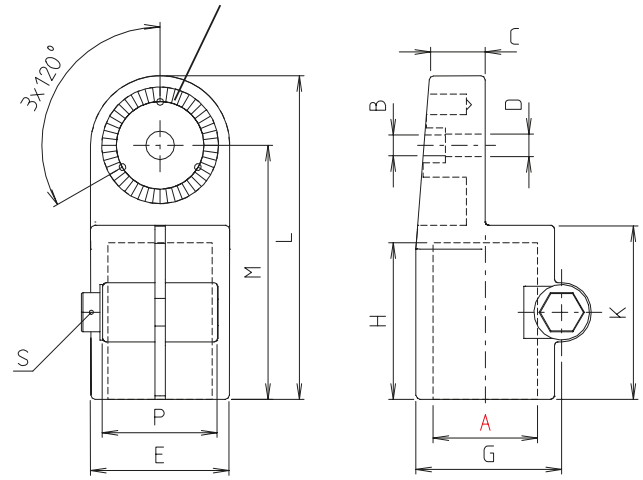

15° toothing internal



Type LP 12–18



Type LP 20–60

LP - Industrial design

[mm]

Code No.	Type	A	B	C	D	E	G	H	K	L	M	P	m [g]	Clamping lever S Code No.
17120001020	LP 12	12,1	M6	10,5	7,5	26	29,4	25	30	57	44	21	62	90210
17140001020	LP 14	14,1											59	
17160001020	LP 16	16,1											56	
17180001020	LP 18	18,1											52	
17200001020	LP 20	20	M8	16	9	40	40	45	50	93	73	33	198	9022401
17250001020	LP 25	25,1											179	
17300001020	LP 30	30,1											150	
17320001020	LP 32	32,2	M10	22	11	56	56	60	68	128	100	48	498	9024301
17350001020	LP 35	35,2											460	
17400001020	LP 40	40,2											410	
17420001020	LP 42	42,2	M10	25	11	66	66	70	78	148	115	58	690	9024401
17450001020	LP 45	45,2											653	
17480001020	LP 48	48,2											609	
17500001020	LP 50	50,2											586	
17600001020	LP 60	60,2	M12	30	13,5	80	80	78	90	174	135	68	940	9024401

Solid Clamps

Strap clamps

Order instruction:

- Standard equipment premounted zinc plated screws
- Clamping levers have to be ordered separately Delivery unassembled See table last column and page 244

On request:

- Stainless steel screws
- Ball-polished
- Colour

serration: possibility of fixation by means of straight pins

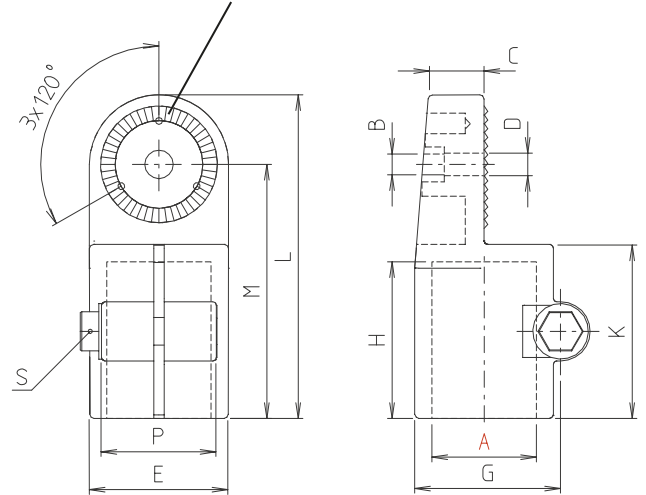

15° toothing external



Type LPZ 12-18



Type LPZ 20-60

LPZ - Industrial design

Code No.	Type	A	B	C	D	E	G	H	K	L	M	P	m[g]	Clamping lever S Code No.
17120010020	LPZ 12	12,1	M6	10,5	7,5	26	29,4	25	30	57	44	21	62	90210
17140010020	LPZ 14	14,1											59	
17160010020	LPZ 16	16,1											56	
17180010020	LPZ 18	18,1											52	
17200010020	LPZ 20	20	M8	16	9	40	40	45	50	93	73	33	198	9022401
17250010020	LPZ 25	25,1											179	
17300010020	LPZ 30	30,1											150	
17320010020	LPZ 32	32,2	M10	22	11	56	56	60	68	128	100	48	498	9024301
17350010020	LPZ 35	35,2											460	
17400010020	LPZ 40	40,2											410	
17420010020	LPZ 42	42,2	M10	25	11	66	66	70	78	148	115	58	690	9024401
17450010020	LPZ 45	45,2											653	
17480010020	LPZ 48	48,2											609	
17500010020	LPZ 50	50,2											586	
17600010020	LPZ 60	60,2	M12	30	13,5	80	80	78	90	174	135	68	940	9024401



Type LQ 20-50

serration: possibility of fixation by means of straight pins

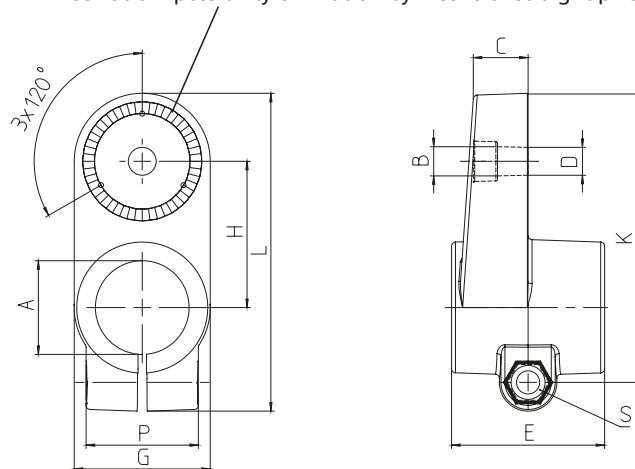

15° toothing internal

LQ - Industrial design

[mm]

Code No.	Type	A	B	C	D	E	G	H	K	L	P	m [g]	Clamping lever S Code No.	
17200003020	LQ 20	20	M8	16	9	45	40	43	85	93	33	102	9022401	
17250003020	LQ 25	25										120		
17300003020	LQ 30	30,1										145		
17320003020	LQ 32	32,2	M10	22	11	60	56	60	116	128	48	470		9024301
17350003020	LQ 35	35,2										421		
17400003020	LQ 40	40,2										375		



Type LF 18



Type LF 18-50

serration: possibility of fixation by means of straight pins

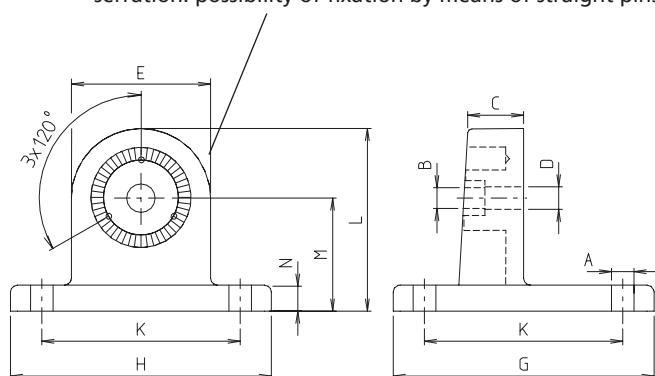

15° toothing internal

LF - Industrial design

[mm]

Code No.	Type	A	B	C	D	E	G	H	K	L	M	N	m [g]
1718000202	LF 18	5,3	M6	13	7	25	50	35	38-40	32,5	20	5	38
1730000202	LF 30	6,5	M8	16	9	40	75	75	57	52,5	33	7,5	151
1740000202	LF 40	8,5	M10	22	11	56	100	100	76	72	44	10	375
1750000202	LF 50	8,5		25		66	125	125	98	85	52	12	582

Solid Clamps

Strap clamps

Order instruction:

- Standard equipment premounted zinc plated screws
- Clamping levers have to be ordered separately Delivery unassembled See table last column and page 244

On request:

- Stainless steel screws
- Ball-polished
- Colour

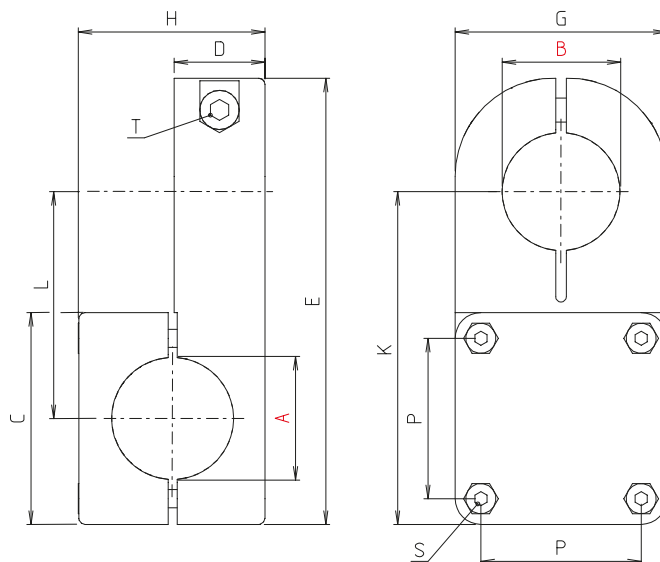

LWR - Block form

[mm]

Code No.	Type	A	B	C	D	E	G	H	K	L	P	m [g]	S	T
													Clamping lever Code No.	
274000040266	LWR 40	40,2	40,2	70	30	146	70	62	110	75	55	654	9021601	9022601

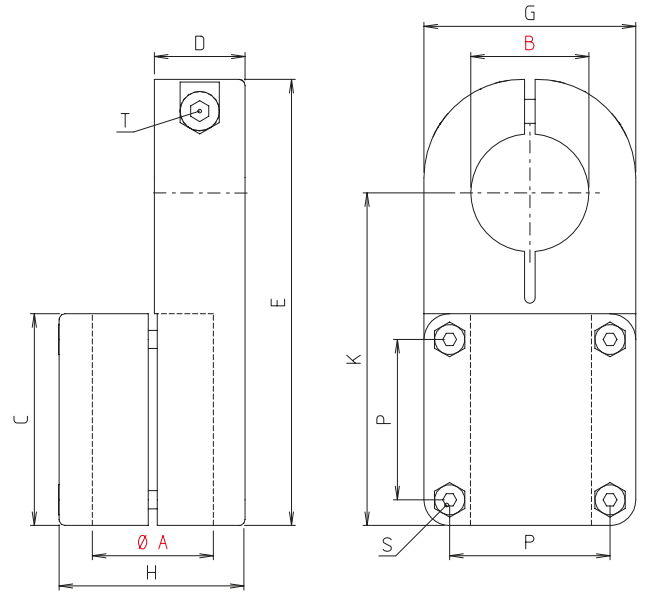

LPR - Block form

[mm]

Code No.	Type	A	B	C	D	E	G	H	K	P	m [g]	S	T
												Clamping lever Code No.	
274000050266	LPR 40	40,2	40,2	70	30	146	70	62	110	53	551	9021601	9022601

Solid Clamps

Strap clamps

Order instruction:

- Standard equipment premounted zinc plated screws
- Clamping levers have to be ordered separately Delivery unassembled See table last column and page 244

On request:

- Stainless steel screws
- Ball-polished
- Colour

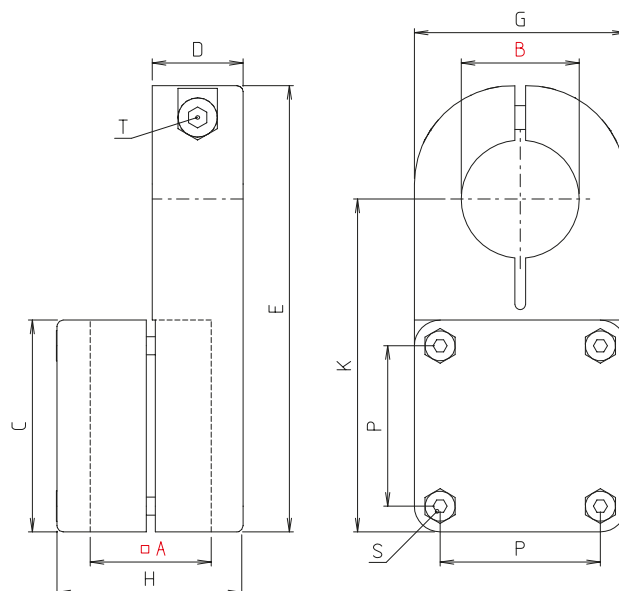

LPV - Block form

[mm]

Code No.	Type	A	B	C	D	E	G	H	K	P	T	m [g]	Clamping lever S Code No.
274000080266	LPV 40	40,4	40,2	70	30	146	70	62	110	53	M8x30	632	9021601

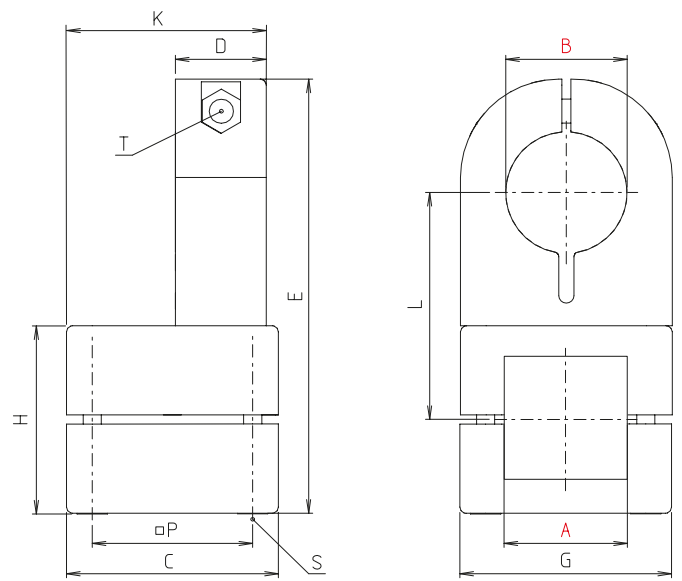

LQV - Block form

[mm]

Code No.	Type	A	B	C	D	E	G	H	K	L	P	T	m [g]	Clamping lever S Code No.
274000090266	LQV 40	40,4	40,2	70	30	142	70	62	66	75	53	M8x30	668	9021601

Solid Clamps

Hinge clamps

Version :

- Hinge clamps

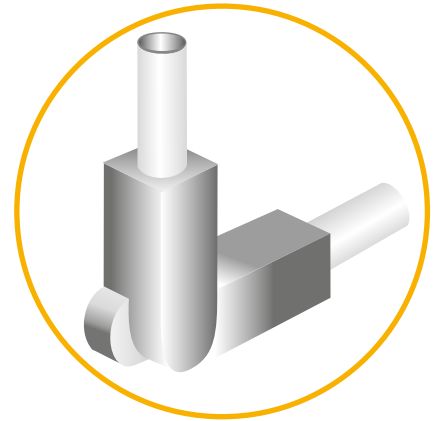

Single-piece elements

- For the quick and inexpensive installation



Industrial design

- Cast aluminium
- Great variety
- Single-piece elements



Multi-piece elements

- Also suitable for subsequent assembly and expansion



Block form

- Cast aluminium
- Higher torque loads
- Plain surface
- Multi-piece elements



Loads hinge clamps

Attention!

The data in the chart do not ensure a guarantee of quality or a warrant characteristic of our products. These are nonbinding standard values which might be not reached in individual cases due to the temperature or surface finish of the clamping profile.

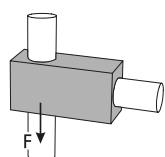

Adhesion force F [KN]

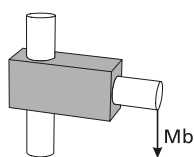

Bending moment Mb [Nm]

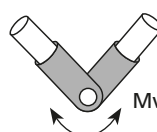

Twisting moment Mv [Nm]

Tightening torque of clamping screws:

- M6: 10 Nm
- M8: 25 Nm
- M10: 50 Nm

Material data sheet available upon request.

Size Type	10			18			30			40			50			60		
	F	Mb	Mv	F	Mb	Mv	F	Mb	Mv	F	Mb	Mv	F	Mb	Mv	F	Mb	Mv
Industrial design																		
GW				2,2	25	7	5,8	85	15	6	233	38	11,9	244	143			
GP				1,1	25	7	4,8	85	15	6	233	38	12	244	143			
GQ				2,2	25	7	4,8	85	15	6	233	38	12	244	143			
GF				2,2	25	7	4,8	85	15	6	233	100	12	244	143			
GWZ				2,2	27	16	5,8	85	148	6	223	376	11,9	317	695			
GPZ				1,1	27	16	4,8	85	148	6	300	300	12	260	400			
GQZ				2,2	27	16	4,8	85	148	6	223	376	12	317	695			
GFZ				2,2	27	16	5,8	69	82	7,4	240	470	7,8	363	695			

Size Type	10			18			30			40			50			60		
	F	Mb	Mv	F	Mb	Mv	F	Mb	Mv	F	Mb	Mv	F	Mb	Mv	F	Mb	Mv
Block form																		
GKR										5,7	253	43	9,3	563	60			
GKRZ										5,7	343	619	9,3	444	548			
GWR										5,7	306	75						
GPR										5,7	306	75						
GPV										2,9	306	75						
GFV										2,9	306	75						

Hinge clamps

Hinge tube connector



Industrial design

Block form



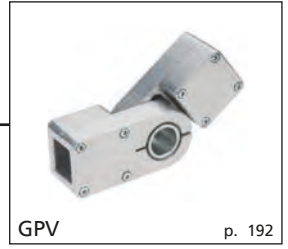
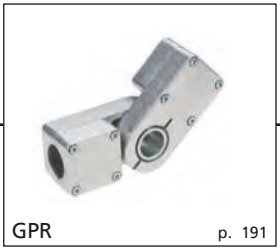
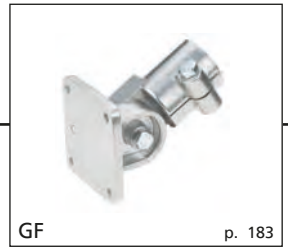

Solid Clamps

Hinge clamps

Order instruction:

- Standard equipment premounted zinc plated screws
- Clamping levers have to be ordered separately Delivery unassembled See table last column and page 244

On request:

- Stainless steel screws
- Ball-polished
- Colour

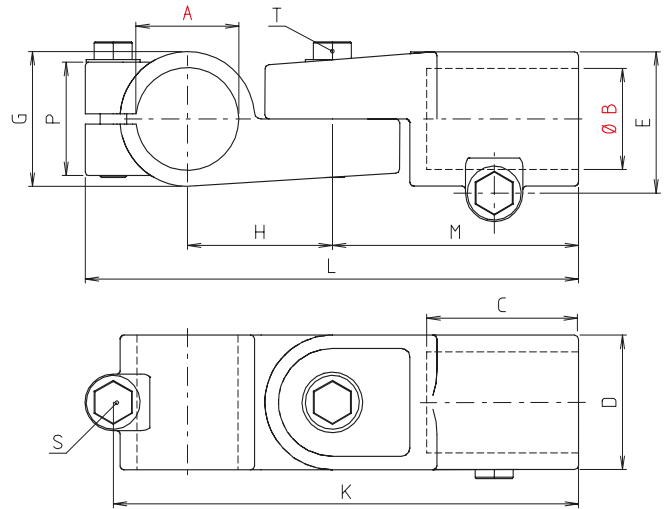

Without tothing- 180° infinitely



Type GW 12-18



Type GW 20-60

GW - Industrial design

[mm]

Code No.	Type	A	B	C	D	E	G	H	K	L	M	P	m [g]	S	T
														Clamping lever Code No.	
181200010200	GW 12	12,1	12,1	25	26	29,4	26	27	87	95,5	44	21	135	90210	90210
181400010200	GW 14	14,1	14,1												
181600010200	GW 16	16,1	16,1												
181800010200	GW 18	18,1	18,1												
182000010200	GW 20	20,1	20,1	45	40	42	40	43	138	147	73	33	387	9022401	9022401
182500010200	GW 25	25,1	25,1												
183000010200	GW 30	30,1	30,1												
183200010200	GW 32	32,2	32,2	60	56	57	56	60	188	200	100	48	961	9024301	-
183500010200	GW 35	35,2	35,2												
184000010200	GW 40	40,2	40,2												
184200010200	GW 42	42,2	42,2												
184500010200	GW 45	45,2	45,2	70	66	66	66	70	218	230	115	58	1335	9024401	-
184800010200	GW 48	48,2	48,2												
185000010200	GW 50	50,2	50,2												
186000010200	GW 60	60,3	60,3												

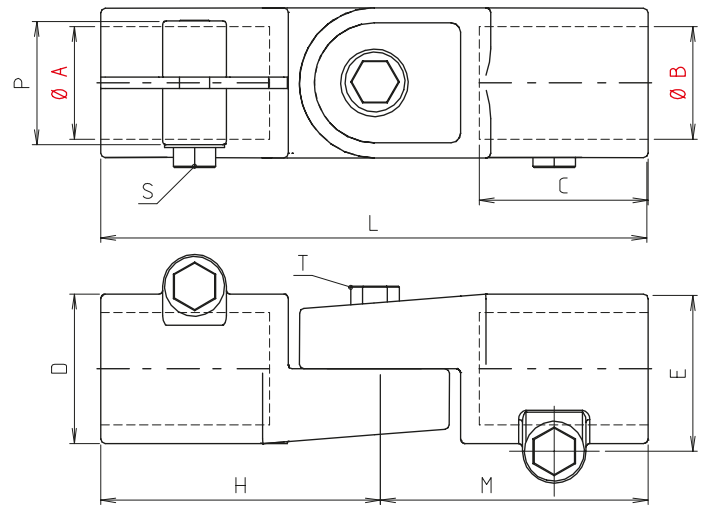

Without toothings- 180° infinitely



Type GP 12-18



Type GP 20-60

GP - Industrial design

Code No.	Type	A	B	C	D	E	H	L	M	P	m [g]	Clamping lever S Code No.
181200000200	GP 12	12,1	12,1	25	26	29,4	44	88	44	21	135	90210
181400000200	GP 14	14,1	14,1								129	
181600000200	GP 16	16,1	16,1								123	
181800000200	GP 18	18,1	18,1								115	
182000000200	GP 20	20,1	20,1	45	40	40	73	146	73	33	419	9022401
182500000200	GP 25	25,1	25,1								374	
183000000200	GP 30	30,1	30,1								328	
183200000200	GP 32	32,15	32,15	60	56	56	100	200	100	48	1028	9024301
183500000200	GP 35	35,15	35,15								972	
184000000200	GP 40	40,15	40,15								871	
184200000200	GP 42	42,2	42,2	70	66	66	115	230	115	58	1440	9024401
184500000200	GP 45	45,2	45,2								1355	
184800000200	GP 48	48,2	48,2								1279	
185000000200	GP 50	50,2	50,2								1213	
186000000200	GP 60	60,25	60,25	80	80	80	135	270	135	68	2200	9024401

Solid Clamps

Hinge clamps

Order instruction:

- Standard equipment premounted zinc plated screws
- Clamping levers have to be ordered separately Delivery unassembled See table last column and page 244

On request:

- Stainless steel screws
- Ball-polished
- Colour

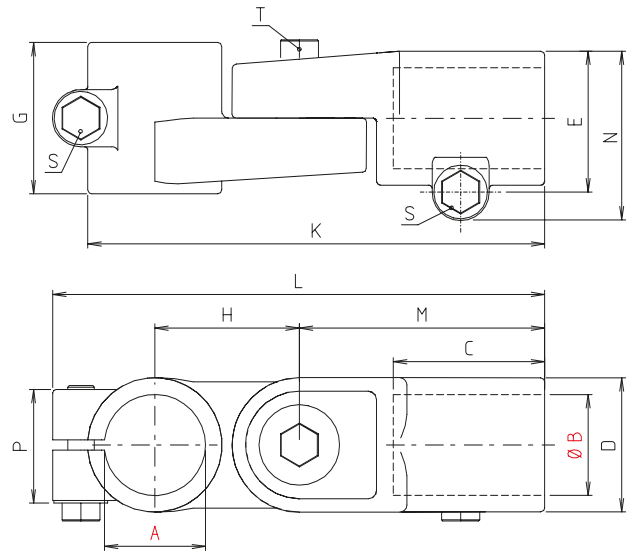

Without tothing 180° infinitely



GQ - Industrial design

Code No.	Type	A	B	C	D	E	G	H	K	L	M	N	P	m [g]	[mm]	
															S	T
															Clamping lever Code No.	
182000030200	GQ 20	20,1	20,1	45	40	40	45	43	136	146	73	50	33	409	9022401	9022401
182500030200	GQ 25	25,1	25,1											369		-
183000030200	GQ 30	30,1	30,1											318		-
183200030200	GQ 32	32,2	32,2	60	56	56	60	60	188	200	100	68	48	1005	9024301	9024301
183500030200	GQ 35	35,2	35,2											922		
184000030200	GQ 40	40,2	40,2											822		

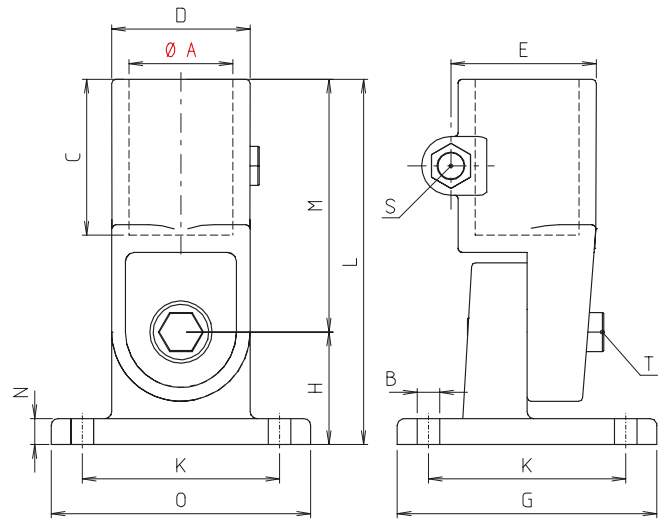

Without tothing 180° infinitely



Type GF 12–18



Type GF 20–50

GF - Industrial design

Code No.	Type	A	B	C	D	E	G	H	K	L	M	N	O	m [g]	Clamping lever S Code No.
18120002020	GF 12	12,1	6	25	26	29,4	50	20	38-40	64	44	5	35	106	90210
18140002020	GF 14	14,1												103	
18160002020	GF 16	16,1												100	
18180002020	GF 18	18,1												96	
18200002020	GF 20	20,1	7	45	40	42	75	33	57	106	73	7	75	371	9022401
18250002020	GF 25	25,1												374	
18300002020	GF 30	30,1												325	
18320002020	GF 32	32,2	9	60	56	57	100	44	76	144	100	10	100	963	9024301
18350002020	GF 35	35,2												880	
18400002020	GF 40	40,2												827	
18420002020	GF 42	42,2	9	70	66	66	125	52	98	167	115	12	125	1378	9024401
18450002020	GF 45	45,2												1287	
18480002020	GF 48	48,2												1233	
18500002020	GF 50	50,2												1213	

Solid Clamps

Hinge clamps

Order instruction:

- Standard equipment premounted zinc plated screws
- Clamping levers have to be ordered separately Delivery unassembled See table last column and page 244

On request:

- Stainless steel screws
- Ball-polished
- Colour

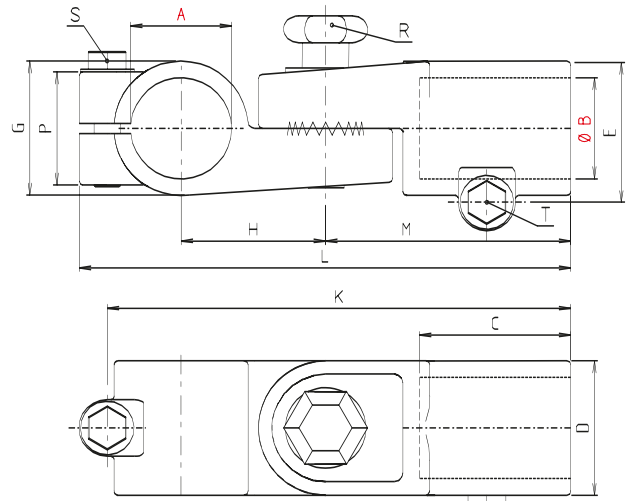

With toothing - rotation of 180°, engaging at 15° intervals



Type GWZ 12-18



Type GWZ 20-60

GWZ - Industrial design

Code No.	Type	A	B	C	D	E	G	H	K	L	M	P	R	T	m [g]	Clamping lever S Code No.
181200040200	GWZ 12	12,1	12,1	25	26	29,4	26	27	84	95,5	44	21	M6x26	M6x16	135	90210
181400040200	GWZ 14	14,1	14,1												129	
181600040200	GWZ 16	16,1	16,1												123	
181800040200	GWZ 18	18,1	18,1												115	
182000040200	GWZ 20	20,1	20,1	45	40	40	40	43	136	146	73	33	M8x40	M8x35	428	9022401
182500040200	GWZ 25	25,1	25,1												391	
183000040200	GWZ 30	30,1	30,1												344	
183200040200	GWZ 32	32,2	32,2	60	56	56	56	60	188	200	100	48	M10x50	M10x50	999	9024301
183500040200	GWZ 35	35,2	35,2												943	
184000040200	GWZ 40	40,2	40,2												861	
184200040200	GWZ 42	42,2	42,2												1361	
184500040200	GWZ 45	45,2	45,2	70	66	66	66	70	218	230	115	58	M10x50	M10x60	1287	9024401
184800040200	GWZ 48	48,2	48,2												1211	
185000040200	GWZ 50	50,2	50,2												1166	
186000040200	GWZ 60	60,3	60,3												2050	
				80	80	80	85	85	260	273	135	68	M12x50	M10x60	2050	9024401

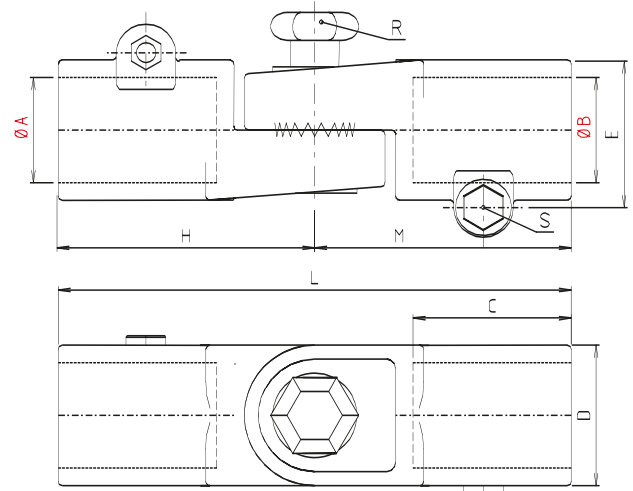

With toothing - rotation of 180°, engaging at 15° intervals



Type GPZ 12-18



Type GPZ 20-60

GPZ - Industrial design

Code No.	Type	A	B	C	D	E	H	L	M	R	T	m [g]	Clamping lever S Code No.
181200050200	GPZ 12	12,1	12,1	25	26	29,4	44	88	44	M6x26	M6x16	135	90210
181400050200	GPZ 14	14,1	14,1									129	
181600050200	GPZ 16	16,1	16,1									123	
181800050200	GPZ 18	18,1	18,1									115	
182000050200	GPZ 20	20,1	20,1	45	40	40	73	146	73	M8x50	M8x35	460	9022401
182500050200	GPZ 25	25,1	25,1									414	
183000050200	GPZ 30	30,1	30,1									370	
183200050200	GPZ 32	32,2	32,2	60	56	56	100	200	100	M10x50	M10x50	1069	9024301
183500050200	GPZ 35	35,2	35,2									1012	
184000050200	GPZ 40	40,2	40,2									916	
184200050200	GPZ 42	42,2	42,2									1482	
184500050200	GPZ 45	45,2	45,2	70	66	66	115	230	115	M10x60	M10x60	1393	9024401
184800050200	GPZ 48	48,2	48,2									1316	
185000050200	GPZ 50	50,2	50,2									1261	
186000050200	GPZ 60	60,3	60,3									2200	

Solid Clamps

Hinge clamps

Order instruction:

- Standard equipment premounted zinc plated screws
- Clamping levers have to be ordered separately Delivery unassembled See table last column and page 244

On request:

- Stainless steel screws
- Ball-polished
- Colour

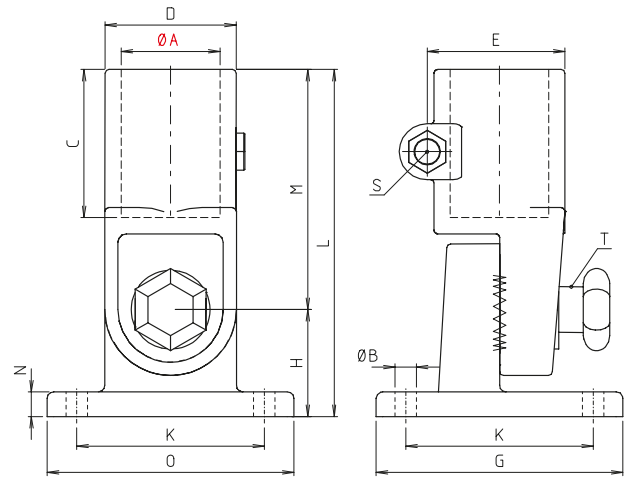

With tothing - rotation of 180°, engaging at 15° intervals



TYPE GFZ 12-18



TYPE GFZ 20-50

GFZ - Industrial design

Code No.	Type	A	B	C	D	E	G	H	K	L	M	N	O	T	m [g]	Clamping lever S code No.
18120007020	GFZ 12	12,1	5,3	25	26	29,4	50	27	40	64	44	5	35	M6x26	106	90210
18140007020	GFZ 14	14,1													103	
18160007020	GFZ 16	16,1													100	
18180007020	GFZ 18	18,1													96	
18200007020	GFZ 20	20,1	7	45	40	40	75	32,5	57	105,5	73	7	75	M8x50	409	9022401
18250007020	GFZ 25	25,1													398	
18300007020	GFZ 30	30,1													368	
18320007020	GFZ 32	32,2	9	60	56	56	100	44	76	144	100	10	100	M10x52	949	9024301
18350007020	GFZ 35	35,2													923	
18400007020	GFZ 40	40,2													866	
18420007020	GFZ 42	42,2	9	70	66	66	125	52	98	167	115	12	125	M10x60	1365	9024401
18450007020	GFZ 45	45,2													1318	
18480007020	GFZ 48	48,2													1279	
18500007020	GFZ 50	50,2													1287	

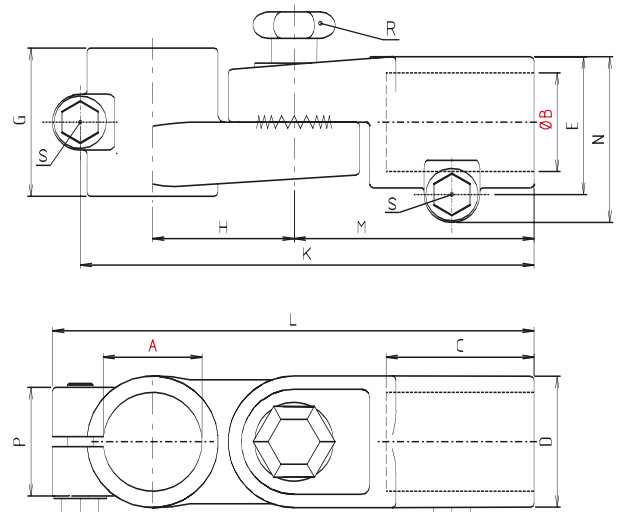

With toothing - rotation of 180°, engaging at 15° intervals



GQZ - Industrial design

Code No.	Type	A	B	C	D	E	G	H	K	L	M	N	P	R	[mm]	
															m [g]	Clamping lever S Code No.
182000060200	GQZ 20	20,1	20,1	45	40	40	45	43	136	146	73	50	33	M8x40	450	9022401
182500060200	GQZ 25	25,1	25,1												412	
183000060200	GQZ 30	30,1	30,1												358	
183200060200	GQZ 32	32,2	32,2	60	56	56	60	60	188	200	100	68	48	M10x52	1045	9024301
183500060200	GQZ 35	35,2	35,2												990	
184000060200	GQZ 40	40,2	40,2												870	

Solid Clamps

Hinge clamps

Order instruction:

- Standard equipment premounted zinc plated screws
- Clamping levers have to be ordered separately Delivery unassembled See table last column and page 244

On request:

- Stainless steel screws
- Ball-polished
- Colour

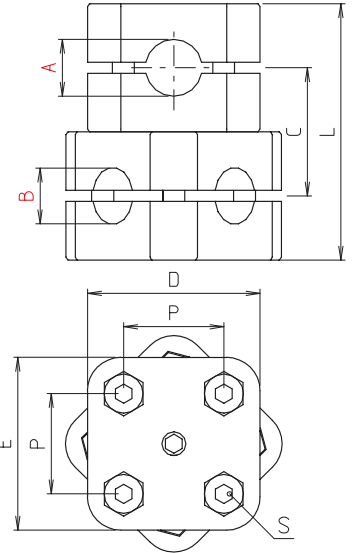

Without tothing 360° infinitely

GKPR - Block form

[mm]

Code No.	Type	A	B	C	D	E	L	P	S	m [g]
290800080266	GKPR 8	8	8	23	31	31	46	18	M4x18	96
291000080266	GKPR 10	10	10							92

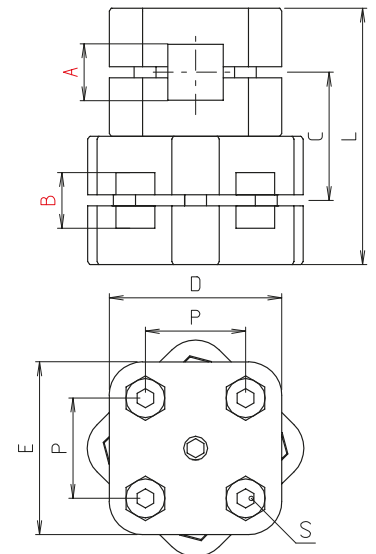

Without tothing 360° infinitely

GKPV - Block form

[mm]

Code No.	Type	A	B	C	D	E	L	P	S	m [g]
291000090266	GKPV 10	10	10	23	31	31	46	18	M4x18	88

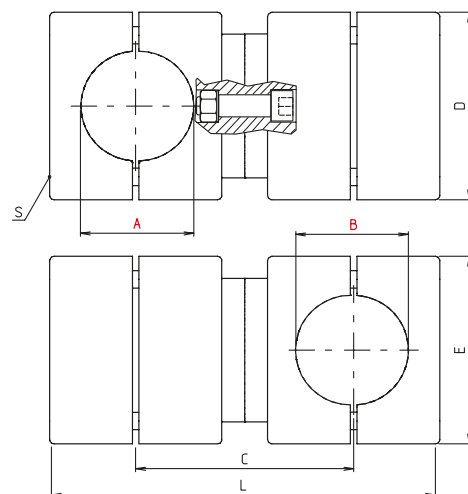

Without tothing 360° infinitely

GKR - Block form

								[mm]		
Code No.	Type	A	B	C	D	E	L	m [g]	Clamping lever S Code No.	
284000080266	GKR 40	40,2	40,2	75	70	70	137	899	9021601	
284800080266	GKR 48	48,3	48,3	100	88	88	179	1946	9022901	
285000080266	GKR 50	50,3	50,3					1903		

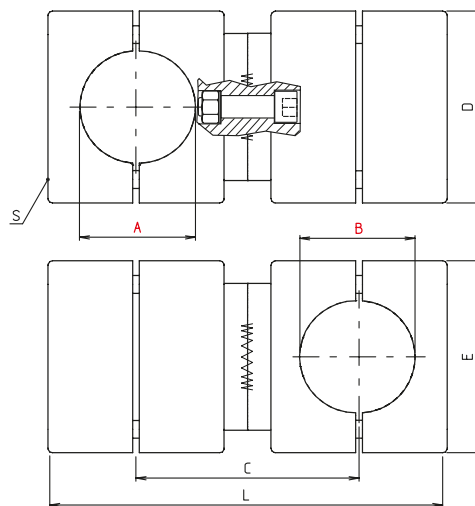

With tothing - rotation of 360°, engaging at 15° intervals

GKRZ - Block form

								[mm]		
Code No.	Type	A	B	C	D	E	L	m [g]	Clamping lever S Code No.	
284000090266	GKRZ 40	40,2	40,2	75	70	70	137	910	9021601	
284800090266	GKRZ 48	48,3	48,3	100	88	88	179	1933	9022901	
285000090266	GKRZ 50	50,3	50,3					1914		

Solid Clamps

Hinge clamps

Order instruction:

- Standard equipment premounted zinc plated screws
- Clamping levers have to be ordered separately Delivery unassembled See table last column and page 244

On request:

- Stainless steel screws
- Ball-polished
- Colour

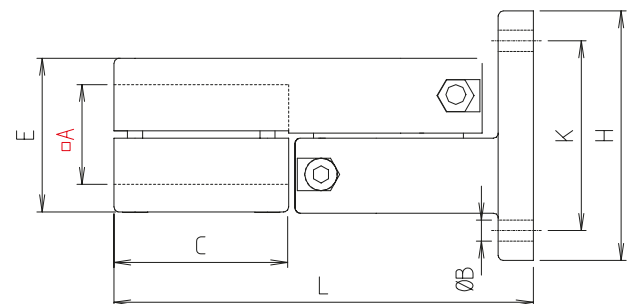
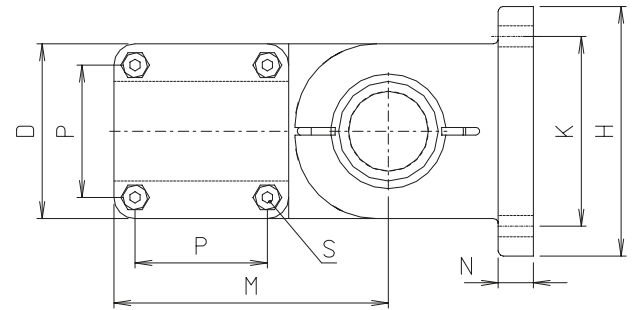

Rotation of 180°, infinitely

GFV - Block form

[mm]

Code No.	Type	A	B	C	D	E	H	K	L	M	N	P	m [g]	Clamping lever S Code No.
28400022026	GFV 40	40,4	8,5	70	70	62	100	76	168	110	14	53	1413	9021601

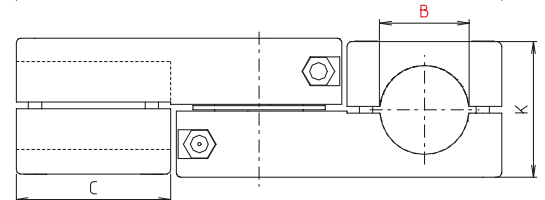
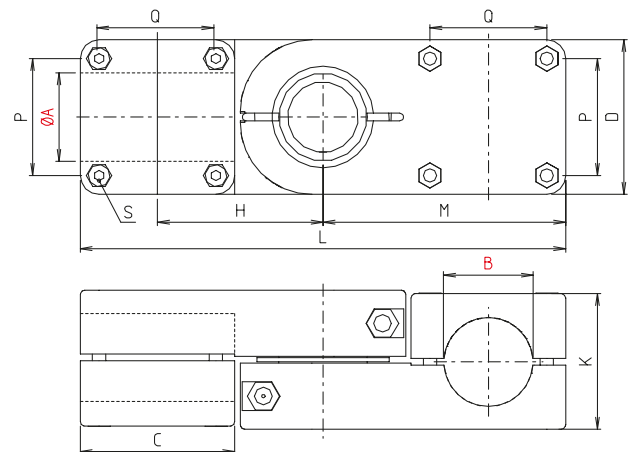

Rotation of 180°, infinitely

GWR - Block form

[mm]

Code No.	Type	A	B	C	D	H	K	L	M	P	Q	m [g]	Clamping lever S Code No.
284000160266	GWR 40	40,2	40,2	70	70	75	62	220	110	53	53	1561	9021601

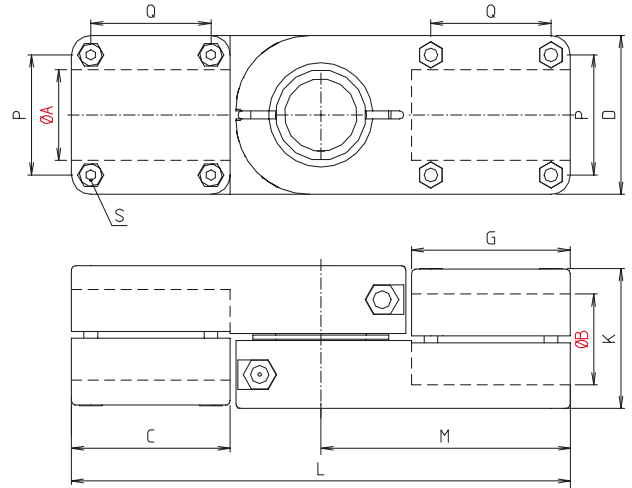

Rotation of 180°, infinitely

GPR - Block form

[mm]

Code No.	Type	A	B	C	D	G	K	L	M	P	Q	m [g]	Clamping lever S Code No.
284000170266	GPR 40	40,2	40,2	70	70	70	62	220	110	53	53	1533	9021601

Solid Clamps

Hinge clamps

Order instruction:

- Standard equipment premounted zinc plated screws
- Clamping levers have to be ordered separately Delivery unassembled See table last column and page 244

On request:

- Stainless steel screws
- Ball-polished
- Colour

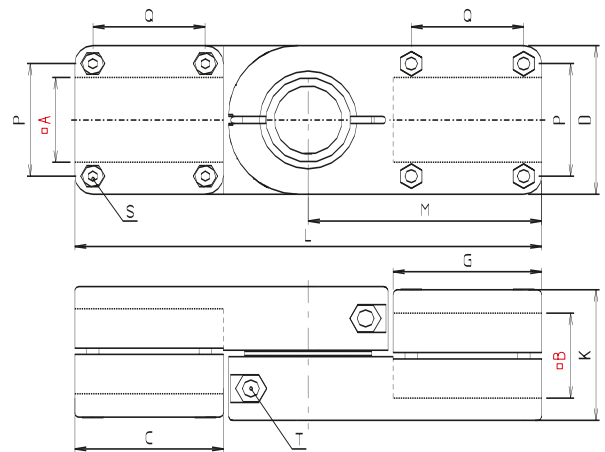

Rotation of 180°, infinitely

GPV - Block form

[mm]

Code No.	Type	A	B	C	D	G	K	L	M	P	Q	R	m [g]	Clamping lever S Code No.
284000210266	GPV 40	40,4	40,4	70	70	70	62	220	110	53	53	M6x55	1486	9021601



Sectional views

**Industrial design without
toothing**
Pivot connected with screw

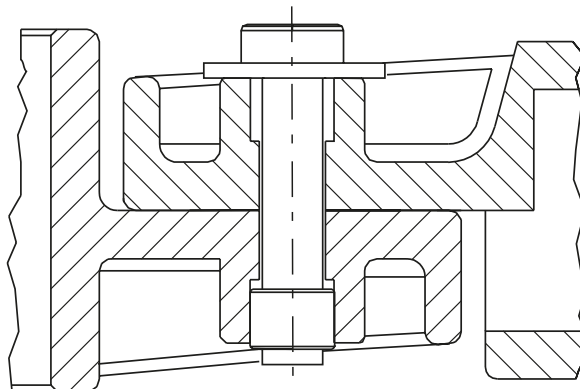

Industrial design with toothing
Pivot connected with star grip screw

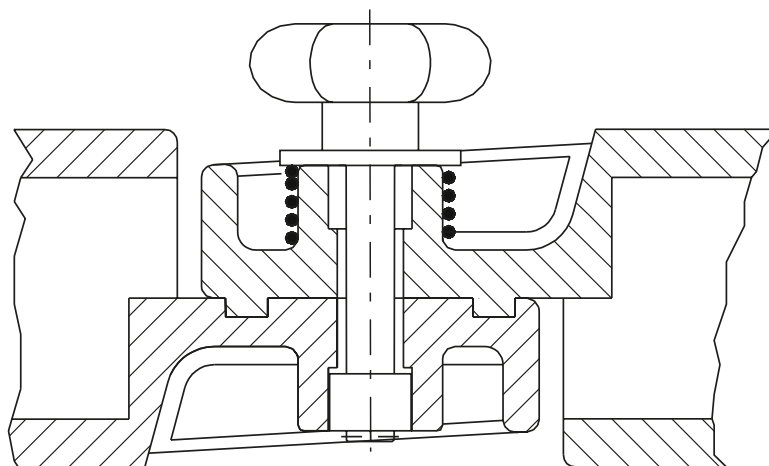

Block form - tube connector
Pivot connected with tube
jointing sleeve and sliding disk

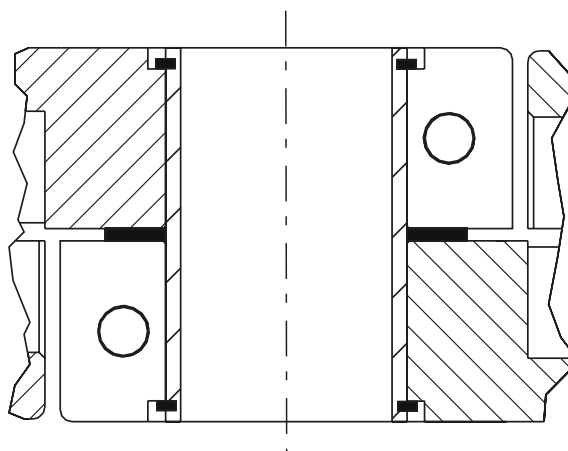

On request, all size combinations of the rated diameters A and B are available within a series.

Solid Clamps

Hinge clamps

Order instruction:

- Standard equipment premounted zinc plated screws
- Clamping levers have to be ordered separately Delivery unassembled See table last column and page 244

On request:

- Stainless steel screws
- Ball-polished
- Colour

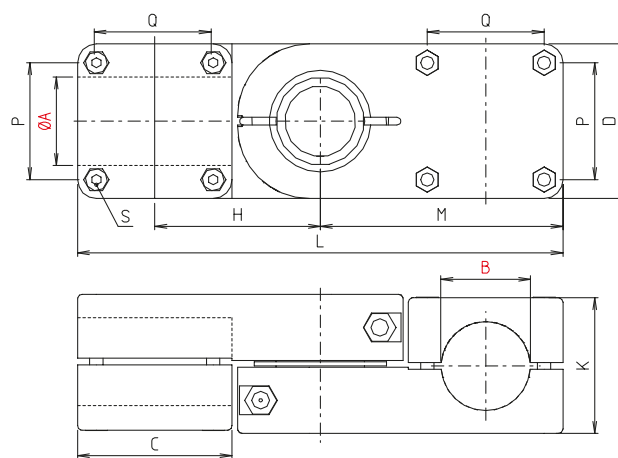
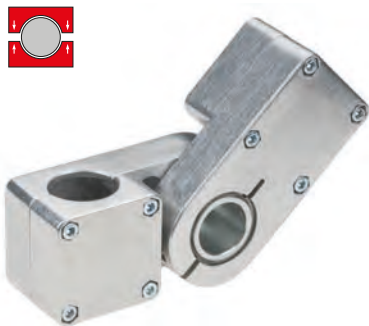

Rotation of 180°, infinitely

GWR - Block form

[mm]

Code No.	Type	A	B	C	D	H	K	L	M	P	Q	m [g]	Clamping lever S Code No.
284000160266	GWR 40	40,2	40,2	70	70	75	62	220	110	53	53	1561	9021601

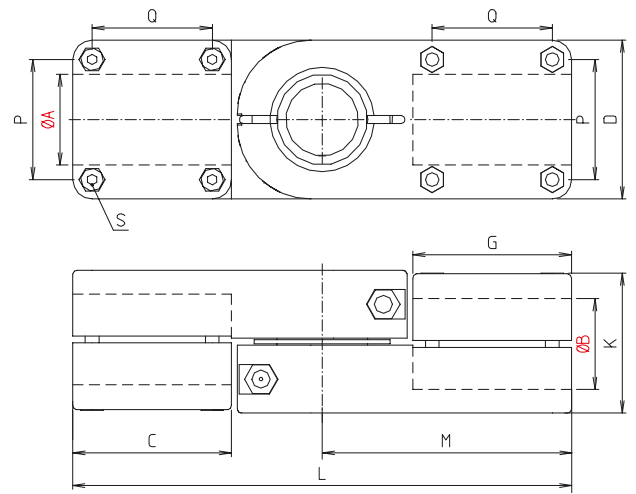

Rotation of 180°, infinitely

GPR - Block form

[mm]

Code No.	Type	A	B	C	D	G	K	L	M	P	Q	m [g]	Clamping lever S Code No.
284000170266	GPR 40	40,2	40,2	70	70	70	62	220	110	53	53	1533	9021601

Solid Clamps

Hinge clamps

Order instruction:

- Standard equipment premounted zinc plated screws
- Clamping levers have to be ordered separately Delivery unassembled See table last column and page 244

On request:

- Stainless steel screws
- Ball-polished
- Colour

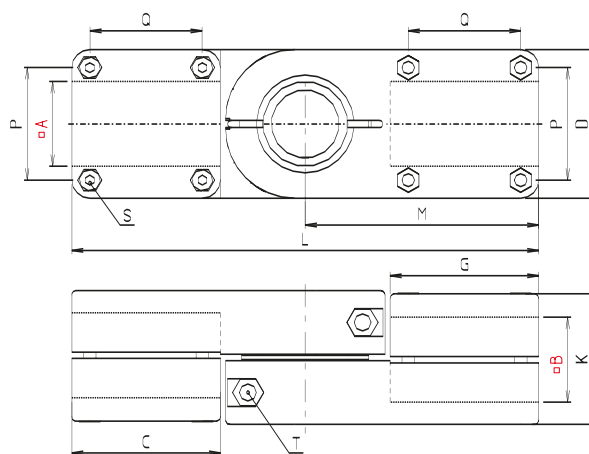
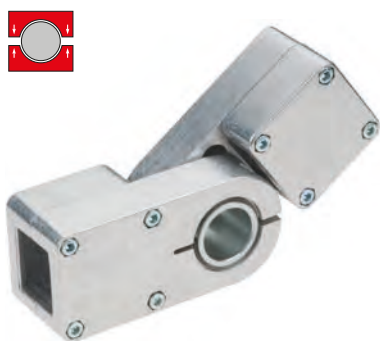

Rotation of 180°, infinitely

GPV - Block form

Code No.	Type	[mm]											m [g]	Clamping lever S Code No.
		A	B	C	D	G	K	L	M	P	Q	R		
284000210266	GPV 40	40,4	40,4	70	70	70	62	220	110	53	53	M6x55	1486	9021601



Sectional views

**Industrial design without
toothing**
Pivot connected with screw

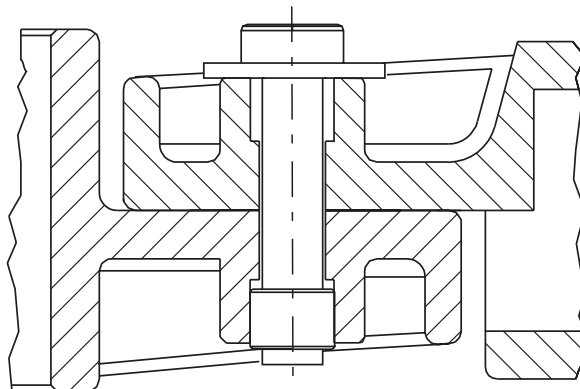

Industrial design with toothing
Pivot connected with star grip screw

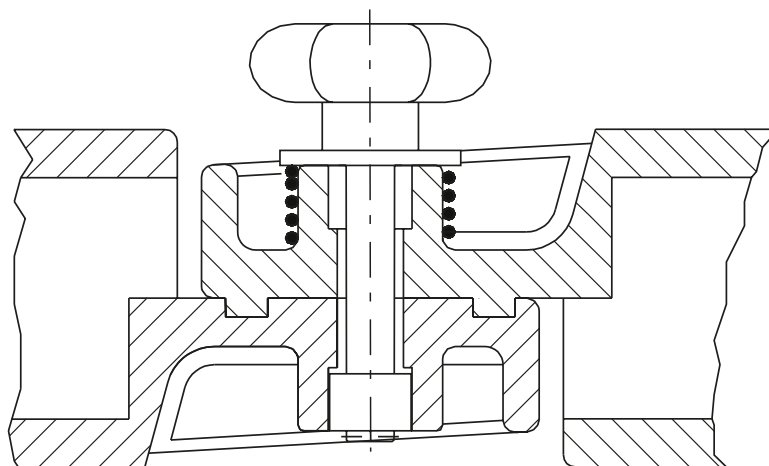

Block form - tube connector
Pivot connected with tube
jointing sleeve and sliding disk

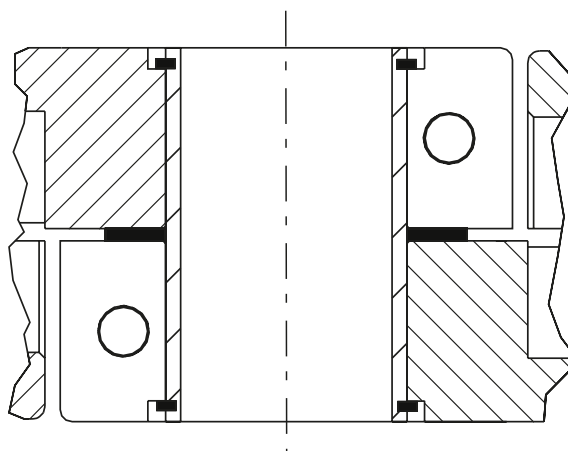

On request, all size combinations of the rated diameters A and B are available within a series.

Solid Clamps

Ball joint

Version:

delivery
from stock



Single-piece elements

- For the quick and inexpensive installation

- Ball joint

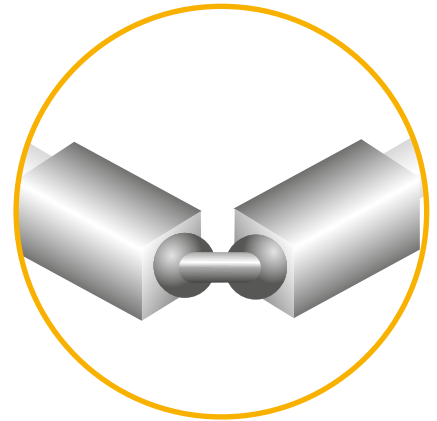

Industrial design

- Cast aluminium
- Great variety
- Single-piece elements

- Features:
- 60° free swivelling / can be turned through 360°
- combinable with tube connectors size 18/30
- The clamps feature a universal connecting plate for flexible integration
- high-strength clamping due to special surfaces

Loads ball joint

Attention!

The data in the chart do not ensure a guarantee of quality or a warrant characteristic of our products. These are nonbinding standard values which might be not reached in individual cases due to the temperature or surface finish of the clamping profile.

Load data

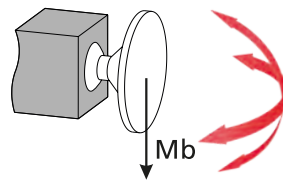

Bending moment Mb [Nm]

Size	18	30
Solid Clamps (aluminium)		
KGW	9	-
KGFS-2	9	-
KGFS	-	40
KGM	-	40
KGMM	-	40
KGGPZ	9	40

Tightening torque of clamping screws:

M6: 10 Nm
M8: 25 Nm

Material data sheet available upon request.

Overview

Ball joint tube connectors

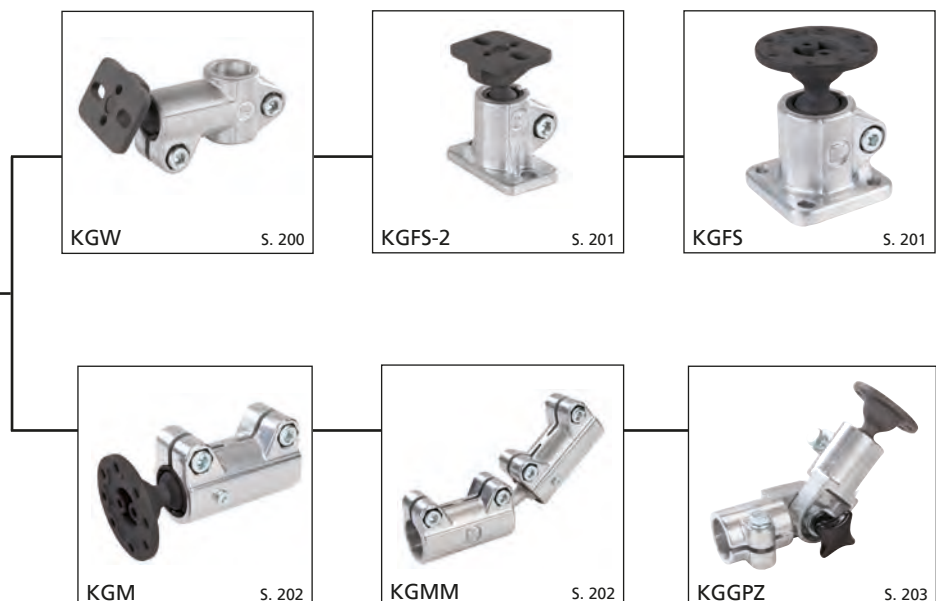

Solid Clamps

Ball joint

Order instruction:

- Standard equipment premounted zinc plated screws

On request:

- Stainless steel screws
- Ball-polished
- Colour

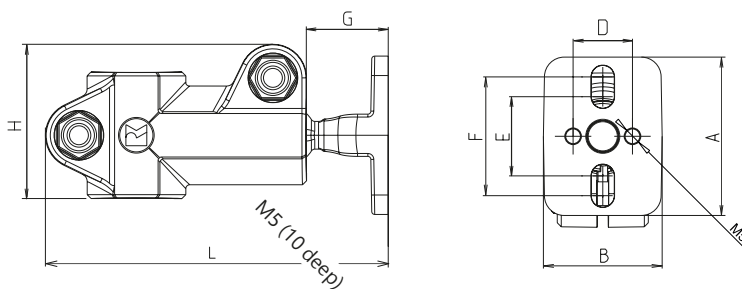

KGW 18 - Industrial design

Code No.	Type	A	D	F	G	H	K	L	M	Q	V	m [g]
111800350260	KGW 18	18,1	15	32	40	20	30	87	30	5,5	21	97

[mm]

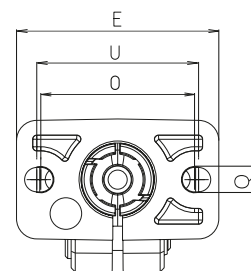
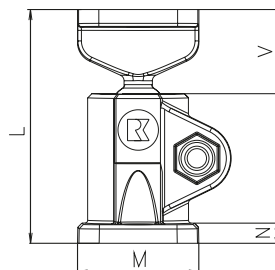
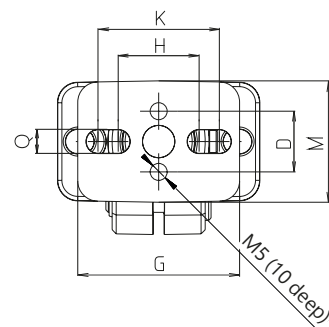

KGFS-2 18 - Industrial design

[mm]

Code No.	Type	D	E	G	H	K	L	M	N	O	Q	U	V	m [g]
131800350260	KGFS-2 18	15	50	40	20	30	58	30	5	38	5,5	40	21	76

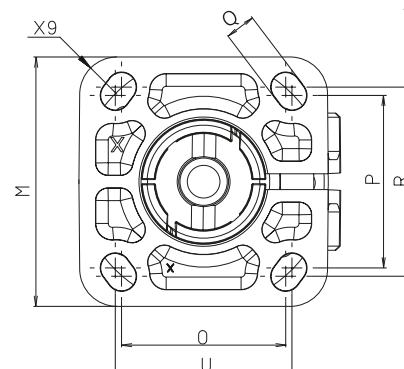
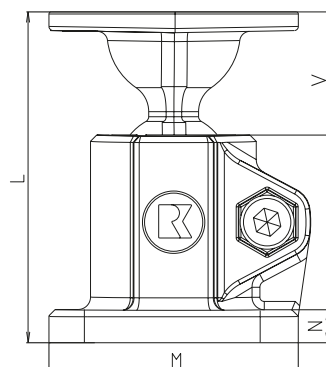
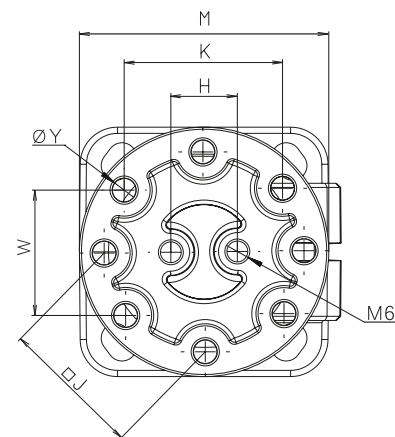

KGFS 30 - Industrial design

[mm]

Code No.	Type	H	J	K	L	M	N	O	P	Q	R	U	V	W	Y	m [g]
133000350260	KGFS 30	16	34	38,1	80	60	8	39,5	41,5	7	45,5	42,5	30	30,2	5,8	227

Solid Clamps

Ball joint

Order instruction:

- Standard equipment premounted zinc plated screws

On request:

- Stainless steel screws
- Ball-polished
- Colour

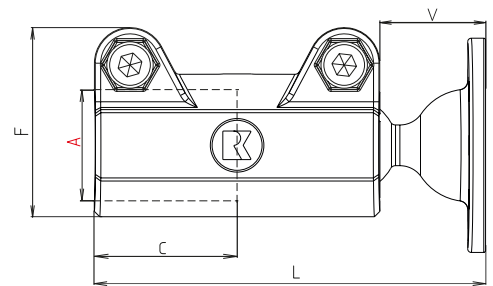
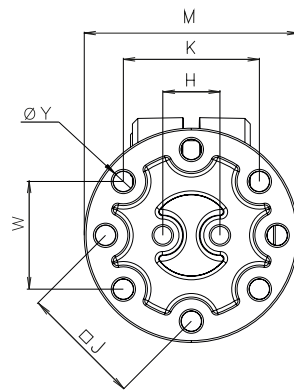
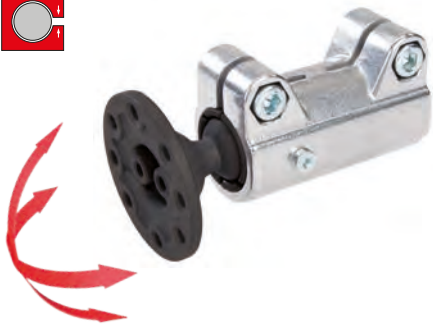

KGMM 30 - Industrial design

[mm]

Code No.	Type	A	C	F	H	J	K	L	M	V	W	Y	m [g]
143000350260	KGMM 30	30,1	40	53	16	34	38,1	110	60	30	30,2	5,8	258



Type KGMM 30

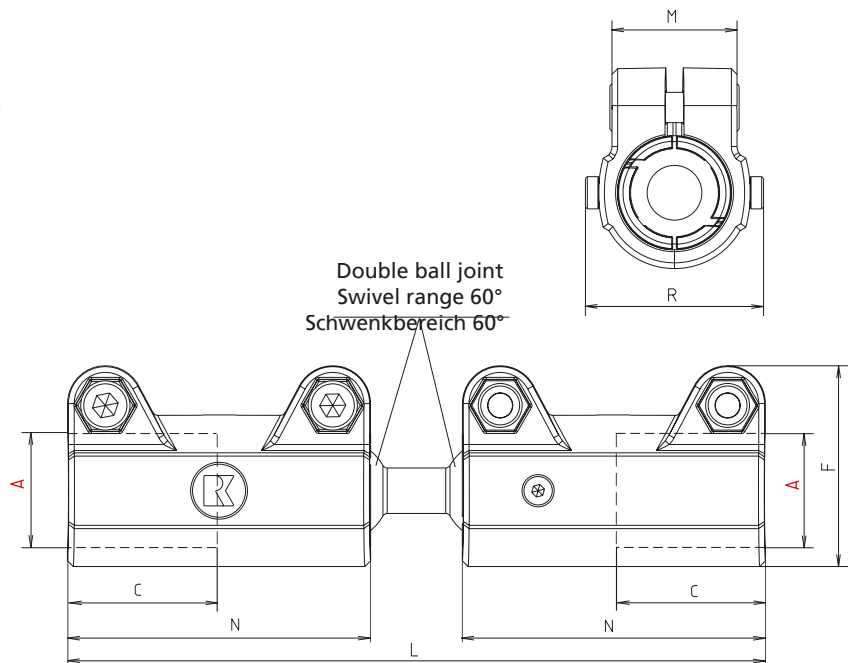

KGMM 30 - Industrial design

[mm]

Code No.	Type	A	C	F	L	M	N	R	m [g]
143000360260	KGMM 30	30,1	40	53	184	33	80	47	445

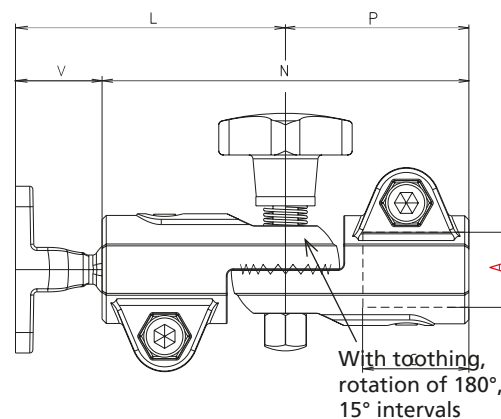
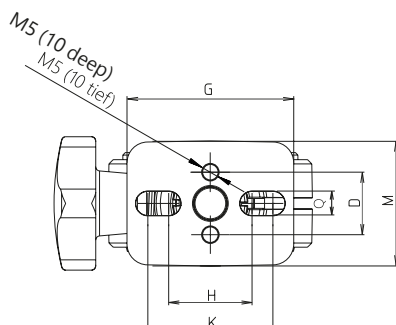
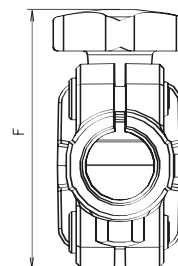

KGGPZ 18 - Industrial design

[mm]

Code No.	Type	A	C	D	F	G	H	K	L	M	N	P	Q	V	m [g]
181800350260	KGGPZ 18	18,1	25	15	62	40	20	30	65	30	88	44	5,5	21	151

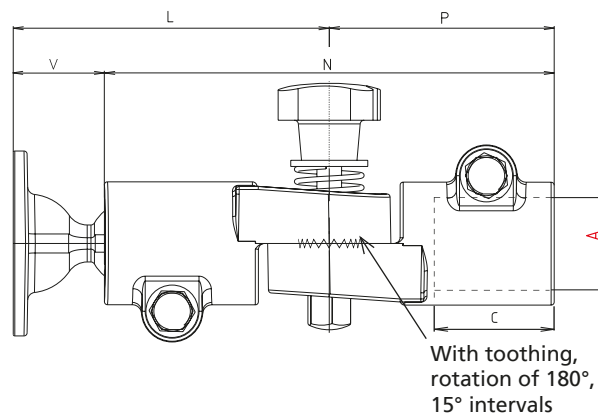
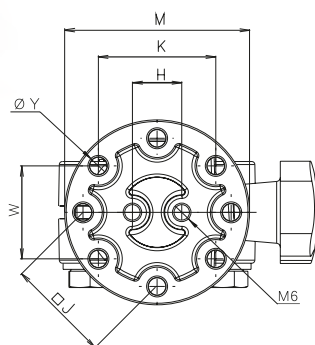
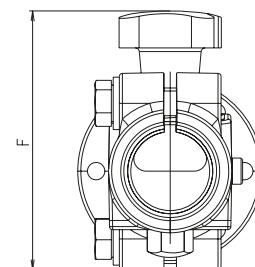
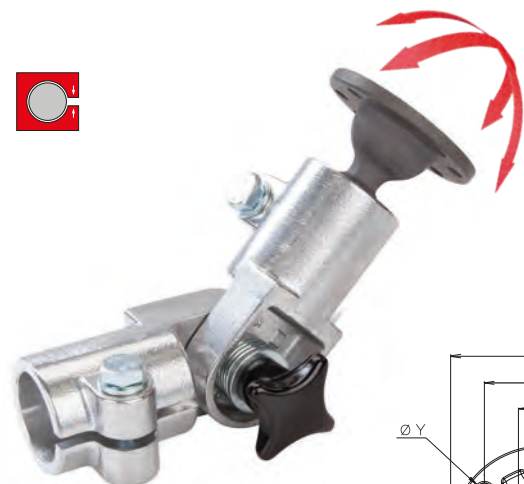

KGGPZ 30 - Industrial design

[mm]

Code No.	Type	A	C	F	H	J	K	L	M	N	P	V	W	Y	m [g]
183000350260	KGGPZ 30	30,1	45	84	16	34	38,1	103	60	146	73	30	30,2	5,8	436

Solid Clamps
Ball joint



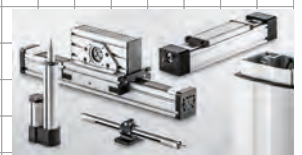
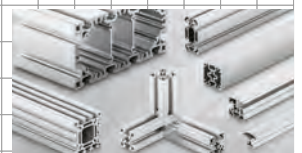
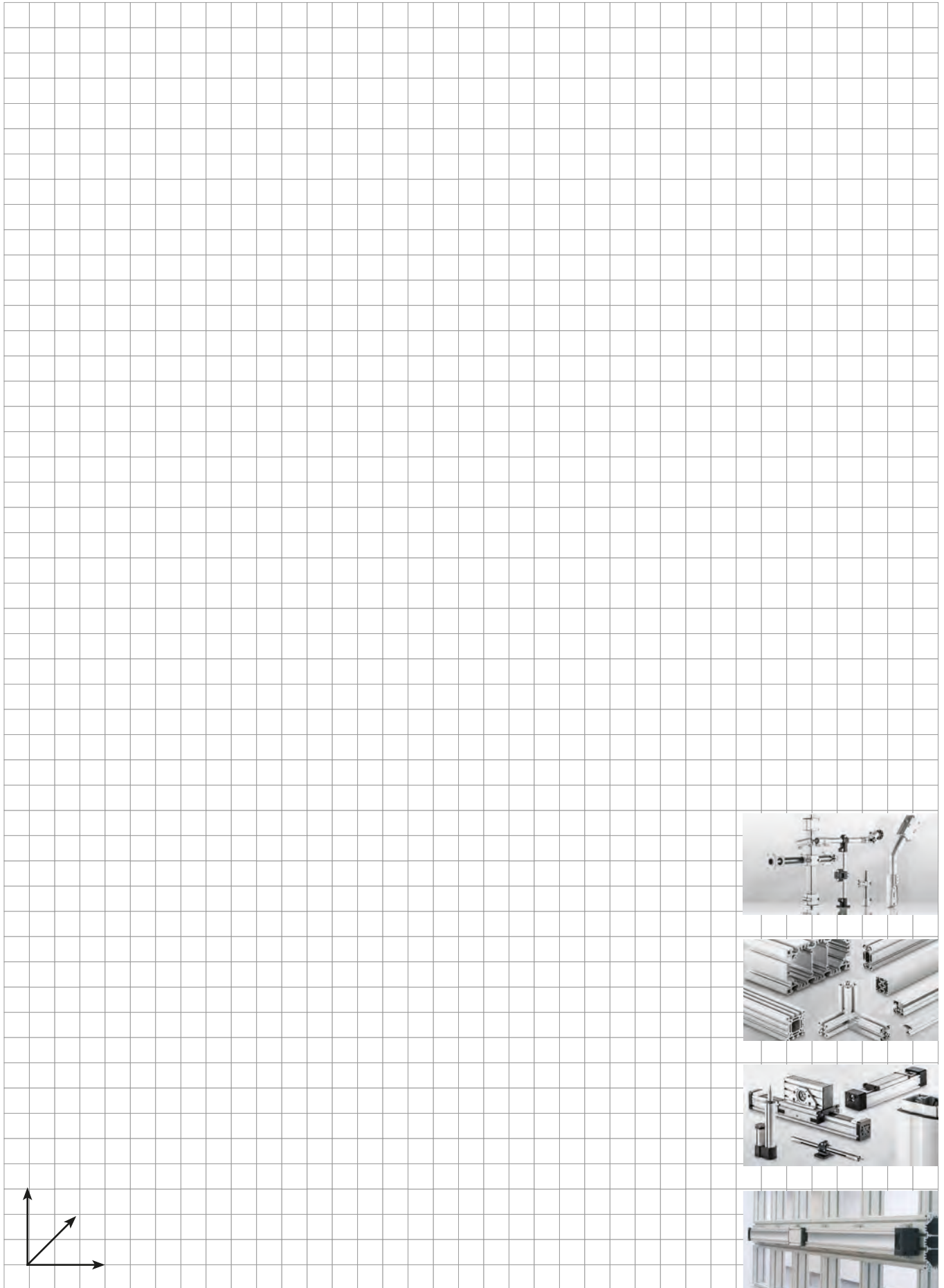

Robust Clamps

Shock-proof load range

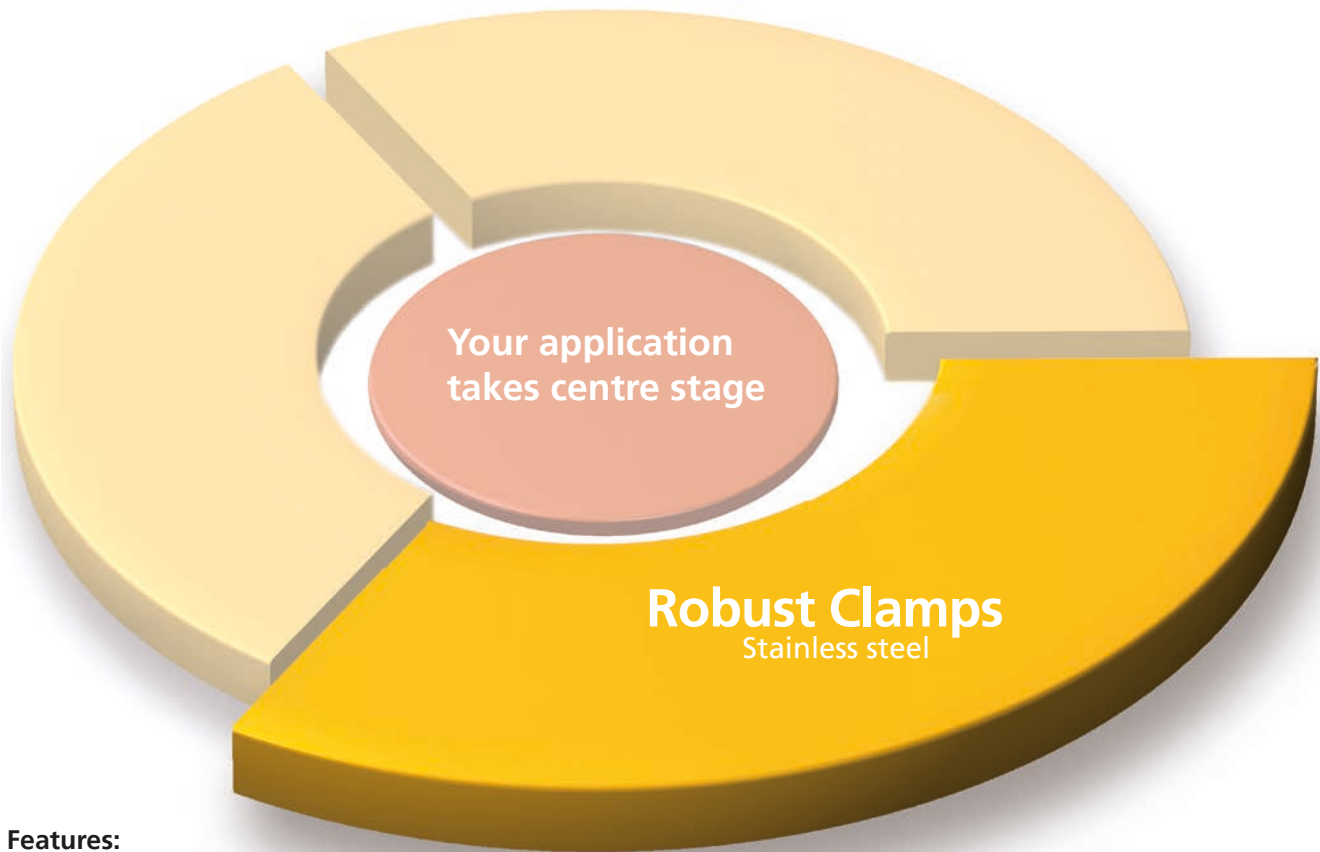

Features:

- Extremely strong
- Vibration proof
- Impact and shock load

... specific demands require specific solutions.



Shock-proof load range

Loads..... page 211

Right angle tube connector..... page 214

Axially parallel tube connector..... page 217

Robust Clamps

Shock-proof load range

... specific demands require specific solutionp.

- Right angle tube connector

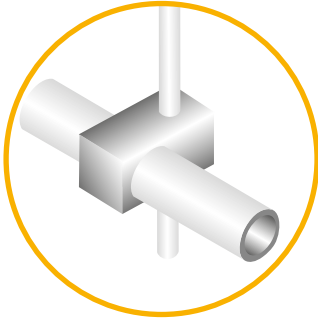

Cross clamps

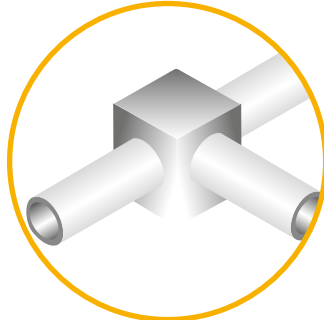

Angle clamps

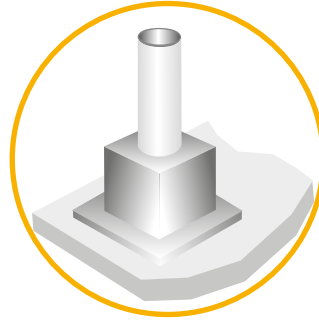

Base clamps

- Axially parallel tube connector

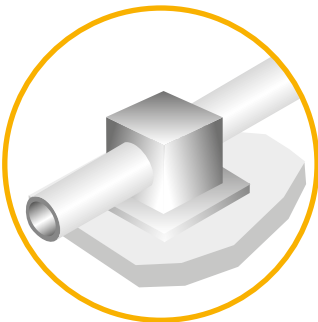

Flange clamps

Table of contents

Right angle tube connector (Single-piece and multi-piece elements)

Cross clamps.....	p. 214
Angle clamps.....	p. 215
Base clamps.....	p. 216

Axially parallel tube connector (Single-piece and multi-piece elements)

Flange clamps	p. 217
---------------------	--------

Accessories

Accessories.....	from p. 230
------------------	-------------

Robust Clamps

Shock-proof load range

Verion:

- Robust Clamps

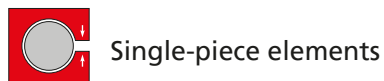

Single-piece elements

- For the quick and inexpensive installation



Cross clamps



Angle clamps



Base clamps



Flange clamps

Stainless steel:

- Impact and shock load
- High temperature resistance
- Corrosion resistance
- Stainless steel precision casting

Loads robust clamps

Attention!

The data in the chart do not ensure a guarantee of quality or a warrant characteristic of our products. These are nonbinding standard values which might be not reached in individual cases due to the temperature or surface finish of the clamping profile.

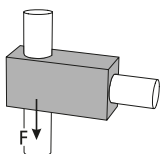

Adhesion force F [KN]

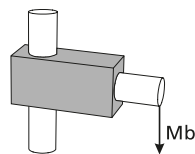

Bending moment M_b [Nm]

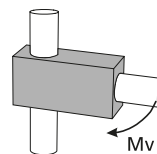

Twisting moment M_v [Nm]

Tightening torque of clamping screws:

M6: 10 Nm
M8: 25 Nm
M10: 50 Nm

Material data sheet available upon request.

Size Type	Ø12 - 18			Ø 30			Ø 40			Ø 50		
	F	M _b	M _v	F	M _b	M _v	F	M _b	M _v	F	M _b	M _v
Cross clamps												
K-VA	7,3	328	37	8,6	975	104	15,5	1780	355	15,5	4140	417
Angle clamps												
W-VA	4,4	449	31	5,8	1570	30	10,1	3360	183	9,4	5560	272
Base clamps												
FS-VA	5,5	175	30	7,2	1420	82	7,9	2790	150	10,3	6350	217
Flange clamps												
FK-VA	6,3	236	44	8,4	740	115	15,2	2580	236	15,5	4250	430

Robust Clamps

Overview

Right angle tube connector



Axially parallel tube connector





Simple probe fixation in an aggressive environment
RK ROSE+KRIEGER Connecting Technology - Robust Clamps 213

Robust Clamps

Cross-/Angle clamps

Order instruction:

- Standard equipment premounted stainless steel screws
- Clamping levers have to be ordered separately
Delivery unassembled
See table last column and page 244



K-VA 12-14



K-VA 16-20

Cross clamps K-VA

Code No.	Type	A	B	C	m [g]	Clamping lever S Code No.
101200003800	K-VA 12	12,1	12,1	20	198	93031
101400003800	K-VA 14	14,1	14,1	20	183	
101600003800	K-VA 16	16,1	16,1	20	165	
101800003800	K-VA 18	18,1	18,1	20	144	
102000003800	K-VA 20	20,1	20,1	21	106	

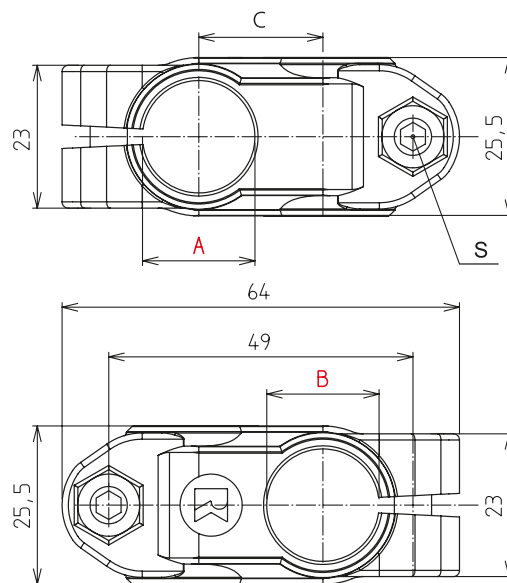

K-VA 30, 40, 50

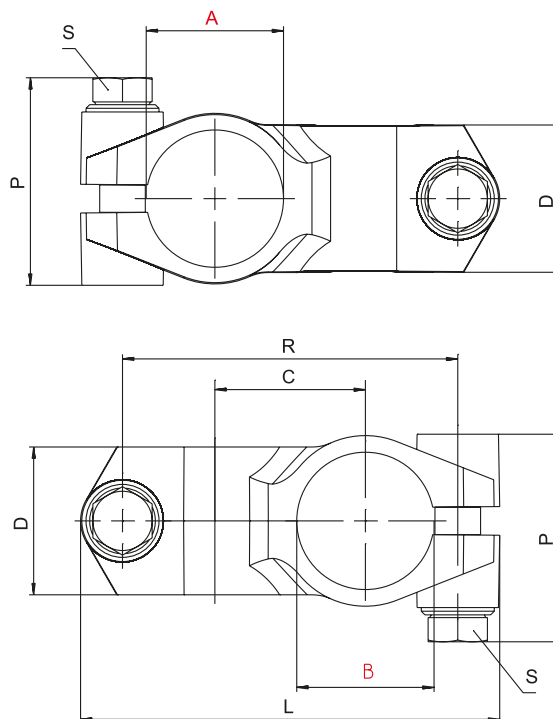

Code No.	Type	A	B	C	D	L	P	R	m[g]	Clamping lever S Code No.
103000003900	K-VA 30	30,1	30,1	33	32,4	92	45,5	73,5	348	9300201
104000003900	K-VA 40	40,17	40,17	42	40,4	118	54	95,5	647	93023
105000003900	K-VA 50	50,22	50,22	54	55	150	56,5	128	1166	93023

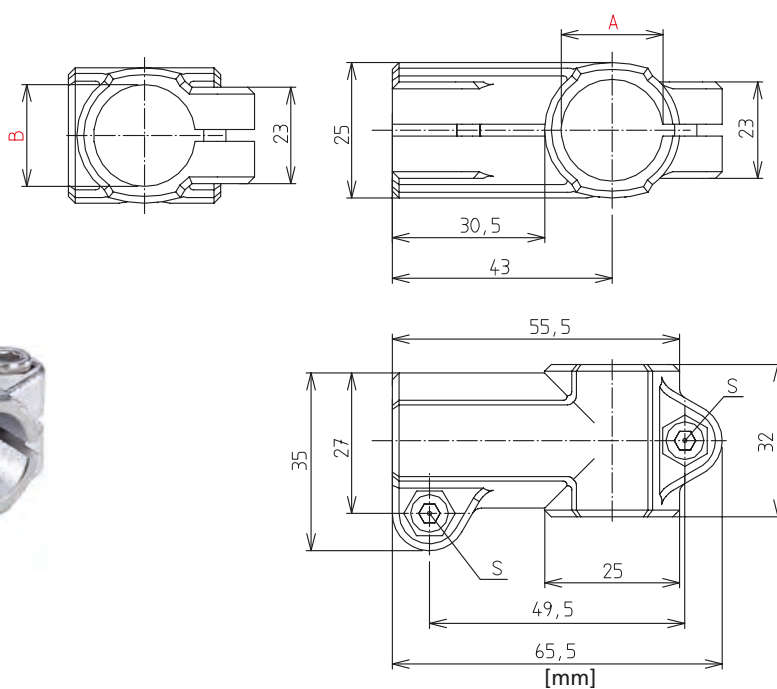

W-VA 12-14



W-VA 16-20

Angle clamps W-VA

Code No.	Type	A	B	m [g]	Clamping lever S Code No.
111200003800	W-VA 12	12,1	12,1	235	93031
111400003800	W-VA 14	14,1	14,1	216	
111600003800	W-VA 16	16,1	16,1	194	
111800003800	W-VA 18	18,1	18,1	169	
112000003800	W-VA 20	20,1	20,1	123	



W-VA 30, 40, 50

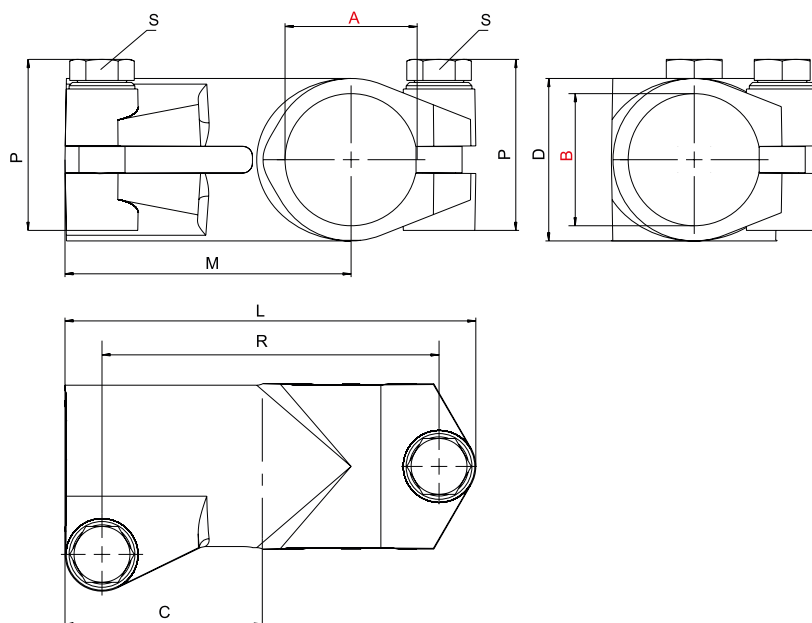

[mm]

Code No.	Type	A	B	C	D	L	M	P	R	m[g]	Clamping lever S Code No.
113000003900	W-VA 30	30,1	30,1	40	38,4	87	58	45,5	69	403	9300201
114000003900	W-VA 40	40,17	40,17	60	50,4	124,9	87	54	102,5	875	93023
115000003900	W-VA 50	50,22	50,22	61,5	60	142		56,5	120	1149	93023

Robust Clamps

Base-/Flange clamps

Order instruction:

- Standard equipment premounted stainless steel screws
- Clamping levers have to be ordered separately
Delivery unassembled
See table last column and page 244



FS-VA 12-14



FS-VA 16-20

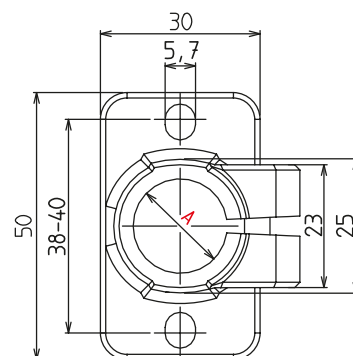
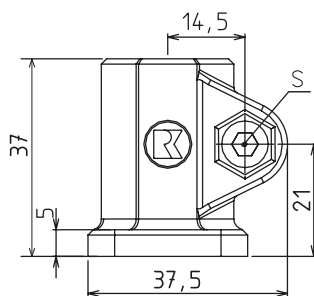

Base clamps FS-VA

Code No.	Type	A	m [g]	Clamping lever S Code No.
13120000380	FS-VA 12	12,1	163	93031
13140000380	FS-VA 14	14,1	151	
13160000380	FS-VA 16	16,1	138	
13180000380	FS-VA 18	18,1	124	
13200000380	FS-VA 20	20,1	99	

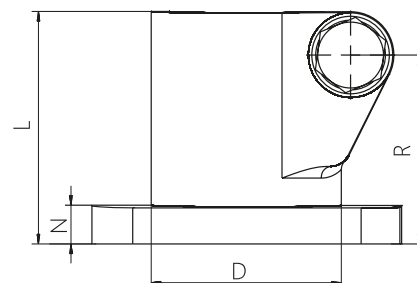

FS-VA 30, 40



FS-VA 50

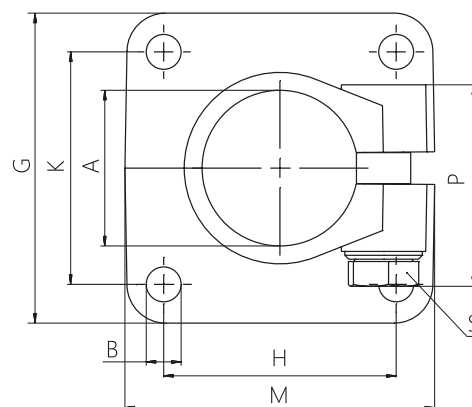

[mm]

Code No.	Type	A	B	D	G	H	K	L	M	N	P	R	m[g]	Clamping lever S Code No.
13300000390	FS-VA 30	30,1	7	37,4	60	40	40	50	60	7	45,5	41	316	9300201
13400000390	FS-VA 40	40,17	9	49,4	80	60	60	60	80	10	54	90	629	93023
13500000390	FS-VA 50	50,22	11	64,5	105	80	80	80	105	14	56,5	54	1163	93023



FK-VA 12-14



FK-VA 16-20

Flange clamps FK-VA

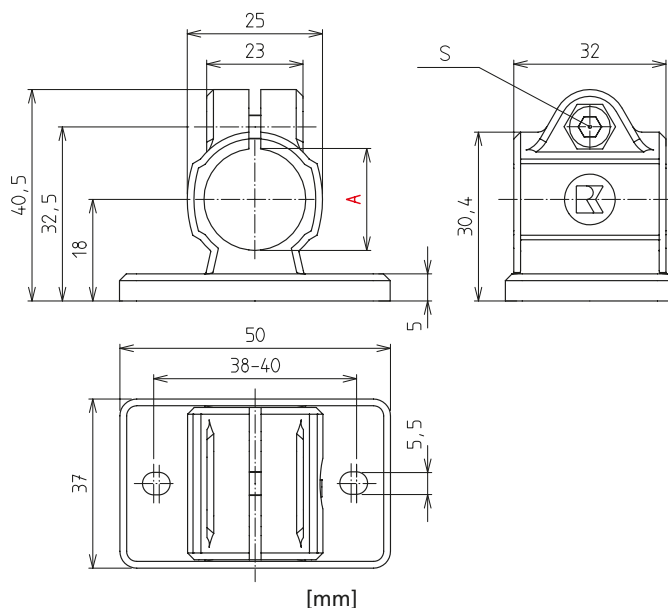

Code No.	Type	A	m [g]	Clamping lever S Code No.
12120000380	FK-VA 12	12,1	178	93031
12140000380	FK-VA 14	14,1	167	
12160000380	FK-VA 16	16,1	156	
12180000380	FK-VA 18	18,1	143	
12200000380	FK-VA 20	20,1	120	

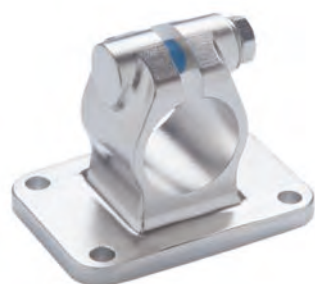

FK-VA 30, 40

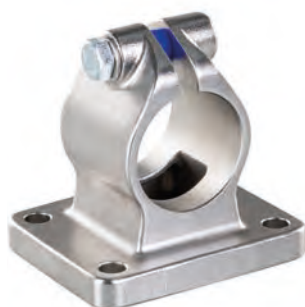

FK-VA 50

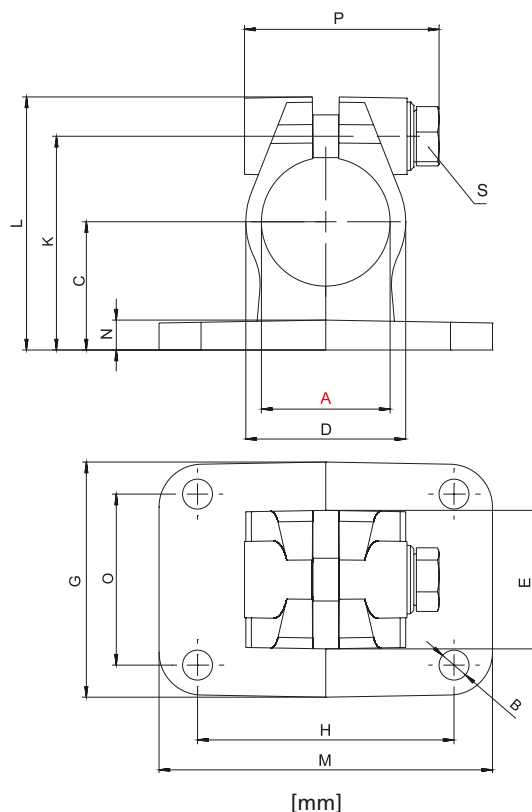

Code No.	Type	A	B	C	D	E	G	H	K	L	M	N	O	P	m[g]	Clamping lever S Code No.
12300000390	FK-VA 30	30,1	7	30	37,4	32,4	55	60	50	59,2	78	7	40	45,5	370	9300201
12400000390	FK-VA 40	40,17	9	42	49,4	46,4	80	60	69	80	80	10	60	54	849	93023
12500000390	FK-VA 50	50,22	11	53	61	55	85	80	90	101	105	14	60	56,5	1022	93023

EMS – stainless steel mounting system

EMS - stainless steel mounting system

Technical data..... p. 221

EMS round tube connectors..... p. 222

EMS square tube connectors..... p. 226



EMS – stainless steel mounting system

A fresh approach to stainless steel connection technology

Smart stainless steel mounting system (EMS) for frame structures in the food industry and in clean rooms

Stainless steel is the material standard for installations in clean rooms, for filling, packaging and conveying systems in the food industry and for all areas which are at risk from corrosion. As a specialist for niche products for these fields, we have now developed stainless steel connection elements which can be used in conjunction with special clamping technology to assemble and disassemble frame structures made from square or round tubing in the common size 40 quickly, reliably and without the need for specialist knowledge.



Video
EMS How it works



Product benefits:

- Straightforward** – assembly without the need for specialist knowledge, using just one tool
- Quick** – considerable time savings thanks to assembly of pre-fabricated modules without reworking
- Flexible** – easy to assemble/disassemble and reusable
- Stable** – high-strength internal clamping mechanism
- Versatile** – available for round tubing and square tubing
- Available** – all components in stock and available for delivery
- With corrosion protection** – all individual parts made of stainless steel
- Sustainable** – suitable for mono-material recycling

Functional illustration

Stainless steel mounting system round:

By screwing in the threaded pins, the inner clamping mechanism is moved in parallel and a friction-locked tube connection is created, which is distributed over four contact points.

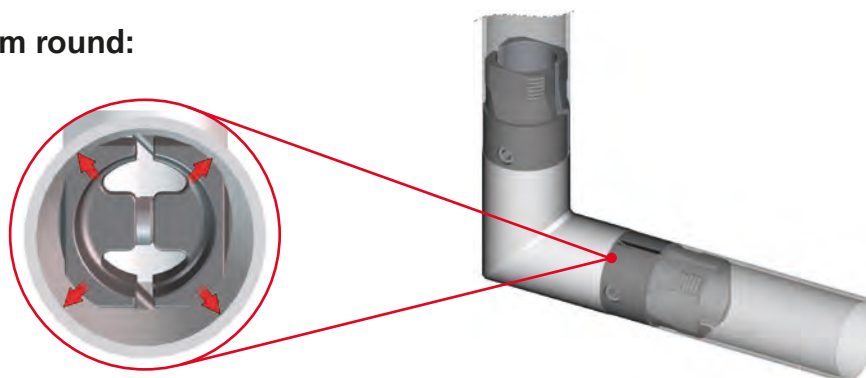

Stainless steel mounting system square:

By screwing in the grub screws, the internal mechanism is moved diagonally across an inclined plane, creating a friction-locked. The tube connection is distributed over four contact surfaces.

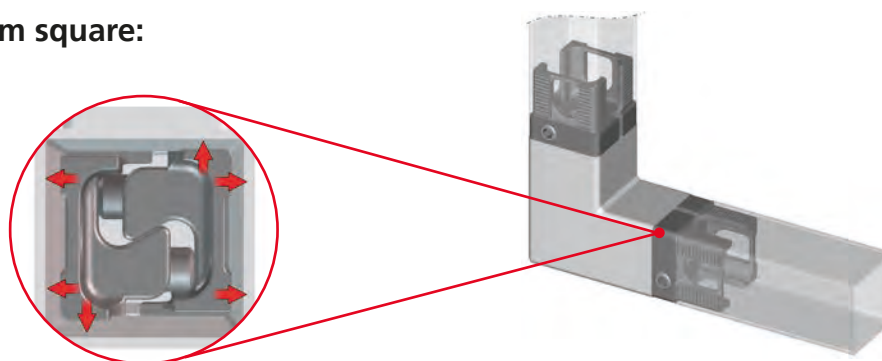

Technical data

Basic information / mechanical properties

- Stainless steel Elements EMS 1.4301 / 1.4308

Loads

Attention!

The data in the chart do not ensure a guarantee of quality or a warrant characteristic of our products. These are nonbinding standard values which might be not reached in individual cases due to the temperature or surface finish of the clamping profile.

Adh. force [N]: static pull

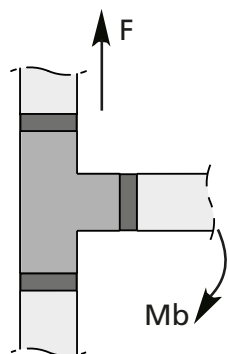

Bending moment Mb [Nm]

Version	Including static safety factor $\nu = 2$		Tightening torque of the clamping screws
	F [N]	Mb [Nm]	Nm
round	1568	77	15
square	1097	63	15

EMS – stainless steel mounting system

Overview

EMS round tube connectors



EMS WIT R 40



EMS WI R 40



EMS WIE R 40



EMS KI R 40



EMS FI R 40

Note:
The adjustable foot is not included
and must be ordered separately.



EMS WIT R 40

Code No.	Type	m [g]
11403653305	WIT R 40	1145

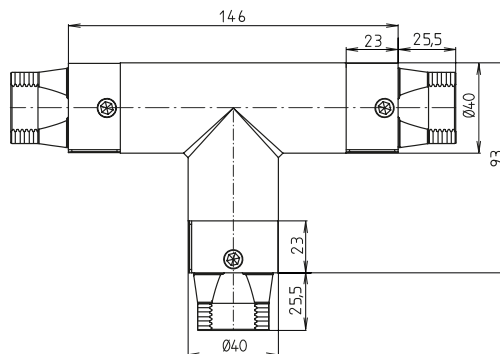

EMS WI R 40

Code No.	Type	m [g]
11403651305	WI R 40	780

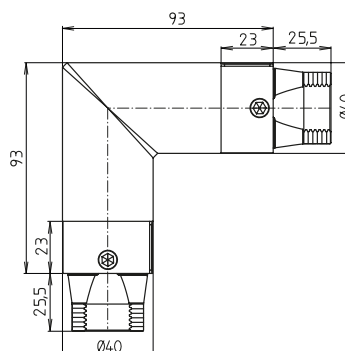

EMS WIE R 40

Code No.	Type	m [g]
11403652305	WIE R 40	1120

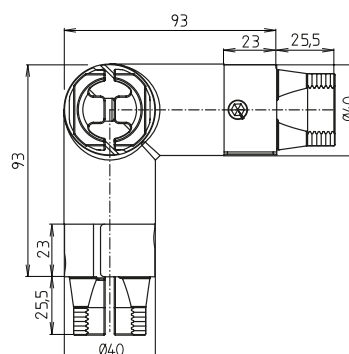

EMS – stainless steel mounting system

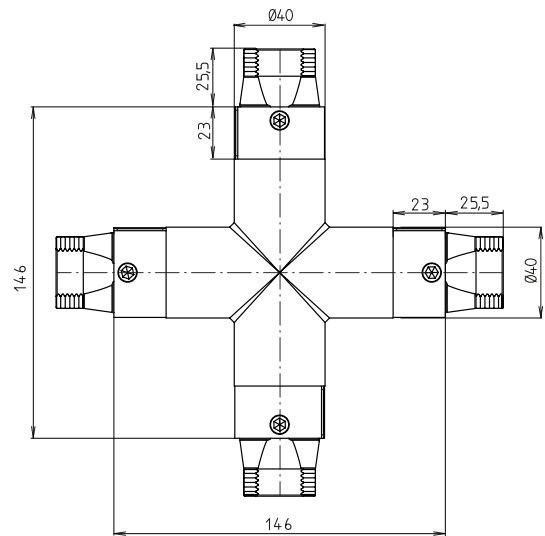

EMS KI R 40

Code No.	Type	m [g]
10403650305	KI R 40	1500

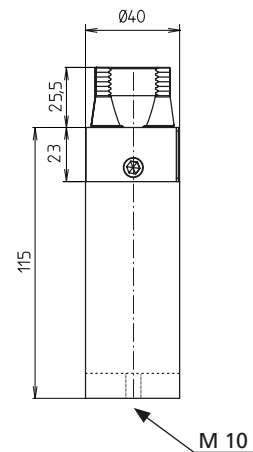

EMS FI R 40

Code No.	Type	m [g]
10403655305	FI R 40	548

Note:
The adjustable foot is not included
and must be ordered separately.



Accessories

EMS round tube connectors

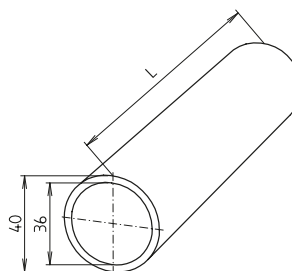

Stainless steel tube

Code No.	Type	m [g/m]
8040022	40x2	1870

every length is possible
max. 6000 mm

Notice:

Due to the manufacturing process, there may be differences in the gloss level of the tubes.



Screw-in adjustable foot stainless steel with vibration damper

Code No.	Type	m [g]
90603	M 10	152

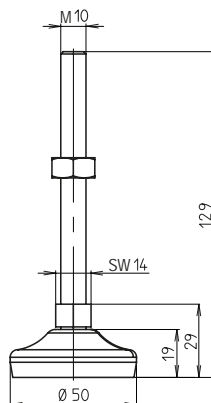

EMS connector R 40

Code No.	Type	m [g]
13403656305	Verb R 40	298

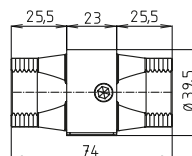

EMS cover R 40

Code No.	Type	m [g]
90721	Ø 40	8

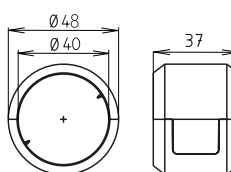

EMS – stainless steel mounting system

Overview

EMS square tube connectors



EMS WIT V 40



EMS WI V 40



EMS WIE V 40



EMS KI V 40



EMS FI V 40

Note:
The adjustable foot is not included
and must be ordered separately.



EMS WIT V 40

Code No.	Type	m [g]
11403643305	WIT V 40	1002

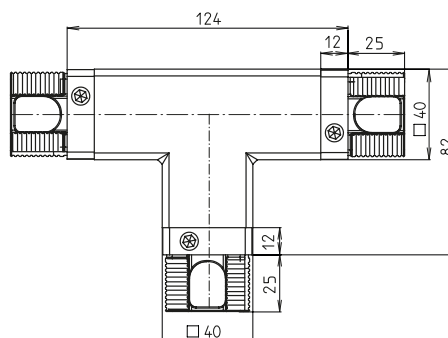

EMS WI V 40

Code No.	Type	m [g]
11403641305	WI V 40	695

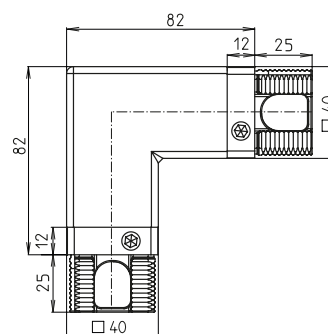

EMS WIE V 40

Code No.	Type	m [g]
11403642305	WIE V 40	1002

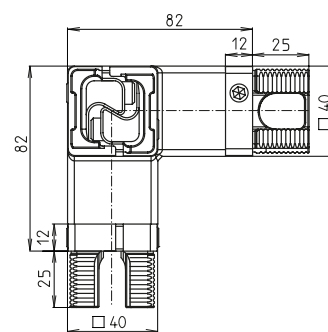

EMS – stainless steel mounting system



EMS KI V 40

Code No.	Type	m [g]
10403640305	KI V 40	1308

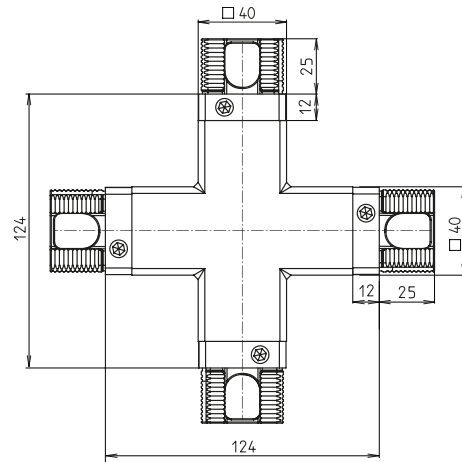

EMS FI V 40

Code No.	Type	m [g]
10403645305	FI V 40	545

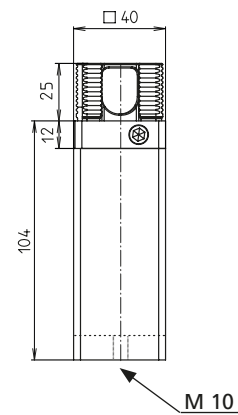

Note:
The adjustable foot is not included
and must be ordered separately.



Accessories

EMS square tube connectors



Stainless steel

Code No.	Type	m [g/m]
8140022	40x2	2330

 every length is possible
max. 5950 mm

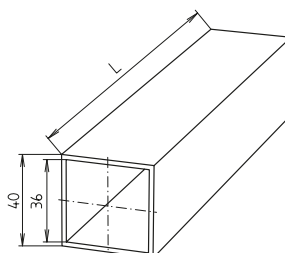

Screw-in adjustable foot stainless steel with vibration damper

Code No.	Type	m [g]
90603	M 10	152

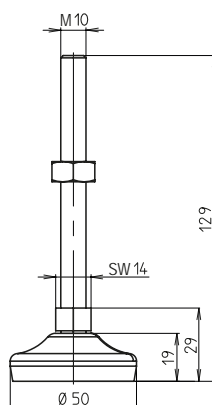

EMS connector V 40

Code No.	Type	m [g]
13403646305	V 40	236

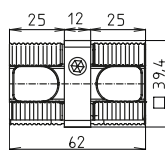

EMS cover V 40

Code No.	Type	m [g]
90720	□ 40	6

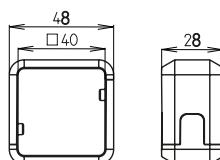

Light-, Solid- & Robust Clamps

Accessoires





Light-, Solid- & Robust Clamps

Accessories from p. 231

Light-, Solid- & Robust Clamps

Accessoires

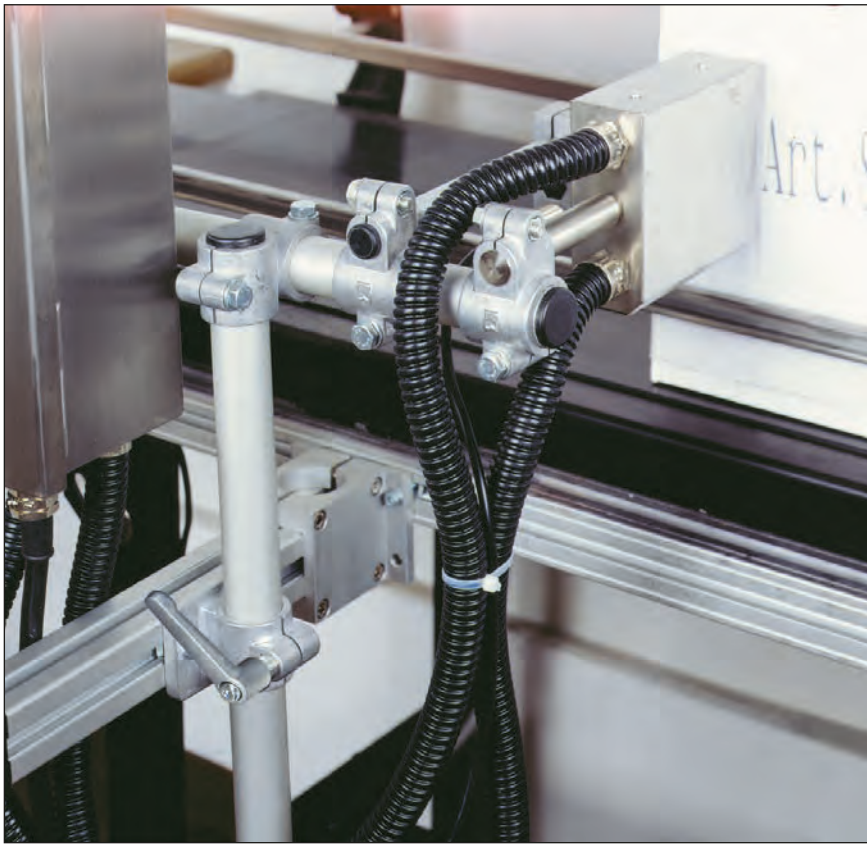

Print head holder on a packaging machine – can be moved as required.

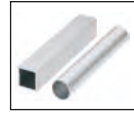

Steel-, Stainless steel-, Aluminium tubes p. 234

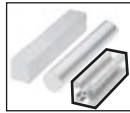

Aluminium bars /-profiles p. 237



Threaded stopper p. 239



Tube stopper p. 240



Special tube fittings p. 241



Adjustable feet p. 242



Castors p. 243



Clamping levers / Insert nuts from p. 244



Adapter sleeve R28 p. 245

Light-, Solid- & Robust Clamps

Accessoires

Order instruction:

- Cut-to-length or standard lengths

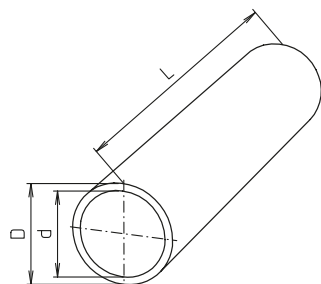

Steel-, Stainless steel tubes / round

[mm]

Code No.	Type	D tol. zinc-plated	L max. zinc-plated	D tol. stainless steel	L max. stainless steel	d
801215_ _ _ _ _	12x1,5	12 ± 0,1	5000	12 ± 0,12	3000	9
801415_ _ _ _ _	14x1,5	14 ± 0,1		14 ± 0,14		11
801515_ _ _ _ _	15x1,5	15 ± 0,1		15 ± 0,15		12
801615_ _ _ _ _	16 x1,5	16 ± 0,1		16 ± 0,16		13
801815_ _ _ _ _	18x1,5	18 ± 0,1		18 ± 0,12	15	
802020_ _ _ _ _	20x2	20 ± 0,1		20 ± 0,12	3000	16
802520_ _ _ _ _	25x2	25 ± 0,1		25 ± 0,25		21
803020_ _ _ _ _	30x2	30 ± 0,1		30 ± 0,10		26
803230_ _ _ _ _	32x3	32 ± 0,15		32 ± 0,15		26
803530* _ _ _ _ _	35x3	35 ± 0,15		-	-	29
804040_ _ _ _ _	40x4	40 + 0,15		40 + 0,12	3000	32
804240* _ _ _ _ _	42x4	42 ± 0,2		-	-	34
804840* _ _ _ _ _	48x4	48 ± 0,2		-	-	40
805040_ _ _ _ _	50x4	50 + 0,2		50 + 0,15	3000	42
806050_ _ _ _ _	60x5	60 + 0,25		60 + 0,20	3000	50
808050* _ _ _ _ _	80x5	80 ± 0,35		-	-	70

Length:
every length is possible
standard lengths:**
0500, 1000, 2000,
3000 und 4000 mm

* Not available in stainless steel
** **standard lengths** only for galvanized zinc-plated

Version:
0 = mill finish St 37-2
1 = galvanized zinc-plated St 37-2 (outer surface only)
2 = stainless steel VA 1.4301

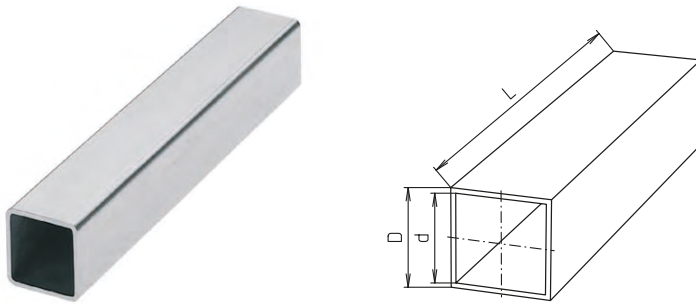

Steel / square

[mm]

Code No.	Type	D tol.	L max. zinc-plated
812010_ _ _ _	20x1	20 ± 0,2	5000
812515_ _ _ _	25x1,5	25 ± 0,25	
813020_ _ _ _	30x2	30 ± 0,25	
814030_ _ _ _	40x3	40 ± 0,3	
815030_ _ _ _	50x3	50 ± 0,3	
816040_ _ _ _	60x4	60 ± 0,35	
818050_ _ _ _	80x5	80 ± 0,5	

Length:
 every length is possible
standard lengths
 0500, 1000, 2000, 3000 und 4000 mm

Version:
 0 = mill finish St 37-2 (20x1 is not possible)
 1 = galvanized zinc-plated St 37-2 (outer surface only)

Stainless steel tubes / square

Standard tube has no tolerance limit

[mm]

Code No.	Type	D tol.	L max.
8120102_ _ _ _	20x1,5	-	6000
8125152_ _ _ _	25x1,5	-	
8130202_ _ _ _	30x2	-	
8140302_ _ _ _	40x3	-	
8150302_ _ _ _	50x3	-	
8160402_ _ _ _	60x4	-	
8180502_ _ _ _	80x5	-	

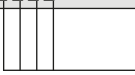
Length:
 every length is possible

Accessoires

Order instruction:

- Cut-to-length or standard lengths

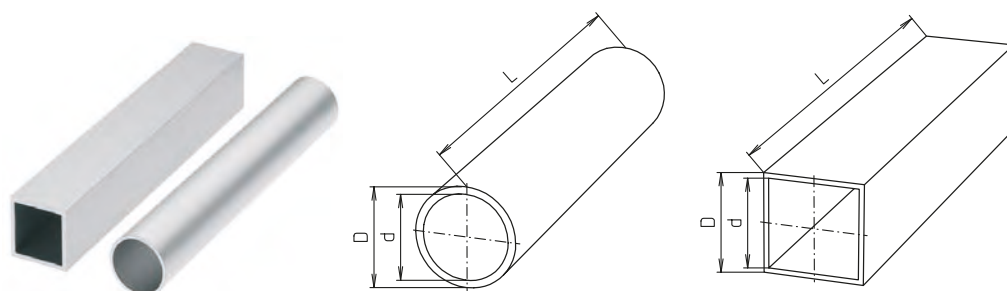

Aluminium tubes

[mm]

Code No.	Type	D tol.	d	L max.
round				
822030_____	20x3	20 ± 0,1	14	6000
823020_____	30x2	30 ± 0,1	26	
824030_____	40x3	40 ± 0,15	34	
825030_____	50x3	50 ± 0,2	44	
826030_____	60x3	60 ± 0,2	54	
square				
832015_____	20x1,5	20 ± 0,2	17	6000
833020_____	30x2	30 ± 0,3	26	
834040_____	40x4	40 ± 0,3	32	
835040_____	50x4	50 ± 0,4	42	
836040_____	60x4	60 ± 0,4	52	

Length:
 every length is possible

Version:
 1 = natural AlMgSi0,5
 2 = clear anodized AlMgSi0,5

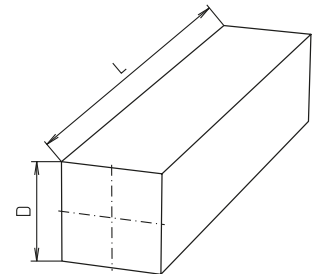
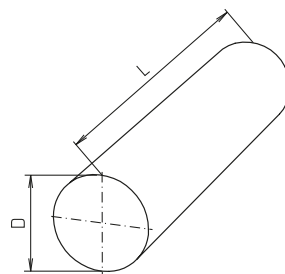

Aluminium bars

[mm]

Code No.	Type	D tol.	L max.
round			
820800_	8	8	6000
821000_	10	10	6000
square			
831000_	10	10	6000

Length:
every length is possible

Version:
1 = natural AlMgSi0,5
2 = clear anodized AlMgSi0,5

Light-, Solid- & Robust Clamps

Accessoires

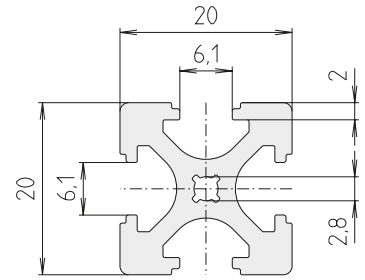

Aluminium profile F-20x20

[mm]

Code No.	Version	Anodized
E01000BBC	bar	natural
E01000BBA	cut	natural
E01000BCC	bar	black
E01000BCA	cut	black

max. 3000 mm

Length:

Standard lengths (clear and black anodized)

500, 1000 und 2000 mm

On request every cut is possible

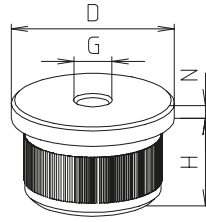

Round tube threaded stopper

[mm]

Code No.	Type	D	G	H	N
Aluminium					
9032101	50x4	50	M10	25	6
9032201			M16		
90323	60x5	60	M10	30	6
90324			M16		

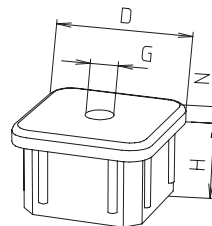

Square tube threaded stopper

[mm]

Code No.	Type	D	G	H	N
Aluminium					
90421	50x3	50x50	M10	25	6
90422			M16		
90427	60x4	60x60	M10	25	8
90425			M16		
90426			M20		

Light-, Solid- & Robust Clamps

Accessoires

Order instruction:

- Purchase only in lot sizes and a multiple of that, see product table below

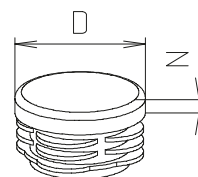

Round tube stopper

[mm]

Code No.	Type	lot sizes	Ø D	N
Black polyethylene				
903011	18x1,5	10, 20, 30... pcs	18	5
903021	20x2	10, 20, 30... pcs	20	5
903031	25x2	10, 20, 30... pcs	25	5
903041	30x2	10, 20, 30... pcs	30	5
90305	32x3	10, 20, 30... pcs	32	5
90312	35x3	10, 20, 30... pcs	35	5
90306	40x3	10, 20, 30... pcs	40	5
90307	40x4	10, 20, 30... pcs		5
90308	45x4	10, 20, 30... pcs	45	5
90309	48x4	10, 20, 30... pcs	48	
90310	50x3 / 50x4	10, 20, 30... pcs	50	5
90311	60x5	10, 20, 30... pcs	60	
Aluminium				
90331	50x4	-	50	6
90332	60x5		60	

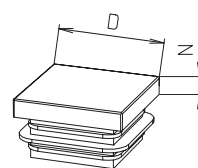
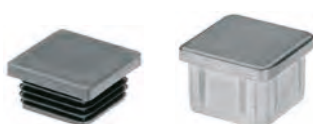

Square tube stopper

[mm]

Code No.	Type	lot sizes	□ D	N
Black polyethylene				
90400C	20x1	10, 20, 30... pcs	20x20	5
90401	25x1,5	10, 20, 30... pcs	25x25	5
90402	30x2	10, 20, 30... pcs	30x30	
90403	35x2,5	10, 20, 30... pcs	35x35	
90404	40x3	10, 20, 30... pcs	40x40	5
	40x4			
90405	50x3	10, 20, 30... pcs	50x50	5
90406	60x4	10, 20, 30... pcs	60x60	
90407	80x5	10, 20, 30... pcs	80x80	
Aluminium				
90411	50x3	-	50x50	6

- Order instruction Steel parts galvanized zinc-plated
- Clamping element for \varnothing and \square tubes
- Clamping capacity for \varnothing 21–40,5 mm
- Clamping capacity for \square 16,5–32 mm

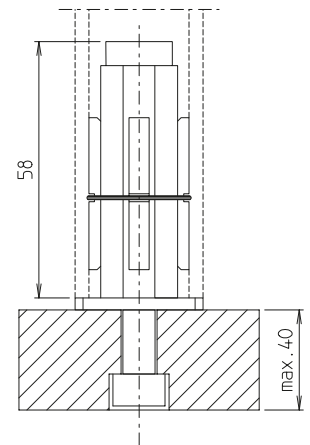

Special tube fittings

[mm]

Code No. ISO 4762	Code No. ISO 10642	\varnothing Type	\square Type
90701	90711	25x2	-
90702	90712	30x2	25x1,5
90702	90712	32x3	-
90702	90712	35x3	-
90705	90715	40x4	30x2
90705	90715	42x4	-
90707	90717	48x4	35x2,5
90708	90718	-	40x3

Light-, Solid- & Robust Clamps

Accessoires

Order instruction:

- Hinge parts PA, black
- Steel parts galvanized zinc-plated

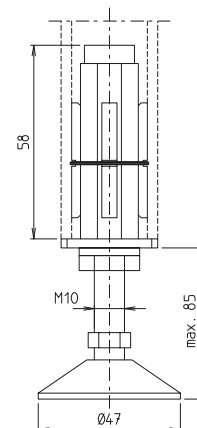

Adjustable feet with special tube fittings

[mm]

Code No.	Ø Type	□ Type
90601	25x2	–
90602	30x2	25x1,5
90602	32x3	–
90602	35x3	–
90605	40x4	30x2
90605	42x4	–
90607	48x4	35x2,5
90608	–	40x3

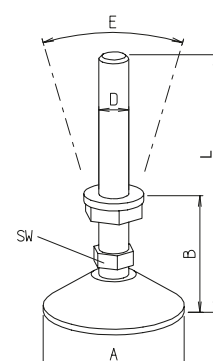

Adjustable feet

[mm]

Code No.	A	B	D	E	L	SW
90611	39	30	M10	30°	118	13
4606301	70	30	M16		130	22
4046301	60	39	M20	30°	185	16
4046311*	60	42			188	16
4046312*	123	70			216	16

* with anti-vibration pad



- Rubber wheel, width 25 mm
- Ball bearing
- polyamide rim
- blue-grey rubber tyre
- thread guard
- load capacity 600 N

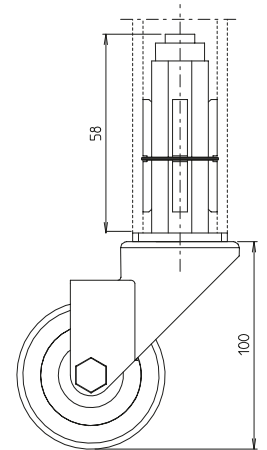

[mm]

Castors with special tube fittings and wheel brake

Code No.	Ø Type	□ Type
90501	25x2	-
90502	30x2	25x1,5
90502	32x3	-
90502	35x3	-
90505	40x4	30x2
90505	42x4	-
90507	48x4	35x2,5
90508	-	40x3

Other versions up on request



- Rubber wheel, width 25 mm
- Ball bearing
- polyamide rim
- blue-grey rubber tyre
- thread guard
- load capacity 600 N

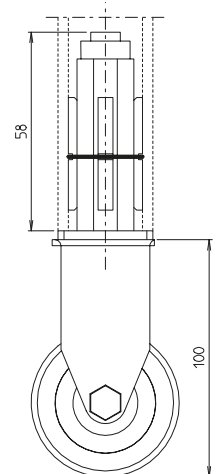

Fixed wheels with special tube fittings

[mm]

Code No.	Ø Type	□ Type
90802	30x2	25x1,5
90802	32x3	-
90802	35x3	-
90805	40x4	30x2
90805	42x4	-
90807	48x4	35x2,5
90808	-	40x

Light-, Solid- & Robust Clamps

Accessoires



(Symbolic representation)

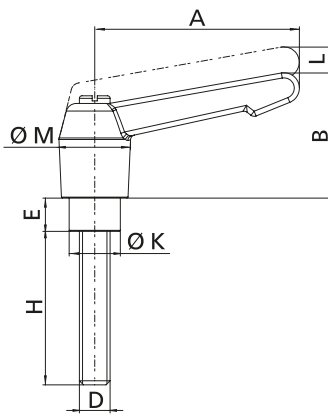

● Instructions:

Regarding its dimensions and adjustability the lever is perfectly adapted to the RK clamp system.

The handle must be lifted high enough to disengage allowing "confined space" tightening or loosening as desired. It relocks by means of spring pressure.

● Materials:

Handle made of zinc pressure casting according to DIN 1743, steel parts quality class 5.8, galvanized.

Clamping lever

Code No.	Type	A	B	D	E	H	K	L	M	m [g]
9020101	HV 5x20	40	27	M5	5,5	20	7,5	3	14	32
90211	HV 6x10	40	27	M6	6,5	10	10	3	14	30
9024901	HV 6x20	40	27	M6	6,5	20	10	3	14	-
90210	HV 6x16	40	27	M6	6,5	16	10	3	14	-
90209	HV 6x18	40	27	M6	6,5	18	10	3	14	-
9021201	HV 6x25	40	27	M6	6,5	25	10	3	14	34
9024701	HV 6x30	40	27	M6	6,5	30	10	3	14	-
9021301	HV 6x35	40	27	M6	6,5	35	10	3	14	38
9021401	HV 6x40	40	27	M6	6,5	40	10	3	14	40
9021501	HV 6x45	40	27	M6	6,5	45	10	3	14	65
9021601	HV 6x55	65	36	M6	6,5	55	10	3	19	75
9021701	HV 6x60	65	36	M6	6,5	60	10	3	19	80
90221	HV 8x15	65	36	M8	8,5	15	13	3	19	68
9022201	HV 8x25	65	36	M8	8,5	25	13	3	19	72
9300201	HV 8x30	65	36	M8	8,5	30	13	3	19	75
9022401	HV 8x35	65	36	M8	8,5	35	13	3	19	80
9022501	HV 8x45	65	36	M8	8,5	45	13	3	19	86
9022601	HV 8x50	65	36	M8	8,5	50	13	3	19	91
9022701	HV 8x55	65	36	M8	8,5	55	13	3	19	100
9022801	HV 8x60	65	36	M8	8,5	60	13	3	19	100
9022901	HV 8x70	80	44,5	M8	8,5	70	13	4	22	120
9023001	HV 8x80	80	44,5	M8	8,5	80	13	4	22	130
9023101	HV 8x90	80	44,5	M8	8,5	90	13	4	22	140
9024101	HV 10x20	80	44,5	M10	10	20	16	4	22	125
90250	HV 10x30	80	44,5	M10	11	30	16	4	22	-
90251	HV 10x35	80	44,5	M10	11	35	16	4	22	-
9024201	HV 10x45	80	44,5	M10	10	45	16	4	22	140
9024301	HV 10x50	80	44,5	M10	10	50	16	4	22	145
9024401	HV 10x60	95	53	M10	10	60	16	4,5	27,5	200
9024501	HV 10x70	95	53	M10	10	70	16	4,5	27,5	200
9024601	HV 10x110	95	53	M10	10	110	16	4,5	27,5	250
9025501	HV 12x40	95	53	M12	10	40	19	4,5	27,5	200
9025301	HV 12x45	95	53	M12	13,5	45	18	4,5	27,5	-
9025601	HV 12x80	80	44,5	M12	10	80	16	4	22	200
9027001	HV 16x72	110	60	M16	12	72	23	5	32,5	-

Upon request:

- Hand levers with plastic handles
- Hand levers with stainless steel threaded fitting

Order instruction:

- Purchase only in lot sizes and a multiple of that, see product table below

- Steel thread insert (exchange pcs)

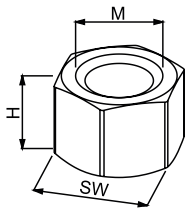

Insert nut

[mm]

Code No.	Materials	Type	lot sizes	H	M	SW
90732	steel	M6SW8	10, 20, 30... pcs	5	6	8
90733	stainless steel	M6SW8	10, 20, 30... pcs			
90734	steel	M6SW10	10, 20, 30... pcs	9	6	10
90736	steel	M8SW11H12	10, 20, 30... pcs	12	8	11
90738	steel	M8SW11H7	10, 20, 30... pcs	7	8	11
90739	stainless steel	M8SW11H7	10, 20, 30... pcs			
90740	steel	M10SW14	10, 20, 30... pcs	10	10	14
90741	stainless steel	M10SW14	10, 20, 30... pcs			

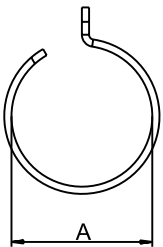

- simple assembly
- axial and rotation locking
- retrofit at existing systems and structures possible

Adapter sleeve R28

[mm]

Code No.	Type	lot sizes	Ø A
913131	Typ 1	5, 10, 15... pcs	28,4 - 28,8
913141	Typ 2	5, 10, 15... pcs	28,0 - 28,3
913151	Typ 3	5, 10, 15... pcs	27,5 - 27,9

Following Solid Clamps / Industrial-Design can be combined with adapter sleeves.

Solid Clamps	Type
Cross clamps	K 30, 30x25, 30x20, KD 30x18, 30x16, 30x15, 30x14, 30x12, KR 30, KVR 30
Angle clamps	W30, WE 30
Base clamps	FS 30
Flange clamps	FK 30, 30-4
Sleeve clamps	M 30, MD 30x25
Insert clamps	S 30

Industrial stairs and working platforms



Platform with staircase on a web offset machine.

The ITAS-system is suitable for many outdoor and indoor applications from the simplest railings to complicated stairs and working platforms.

The easy "socket connection principle" of the internal tension system reduces construction and assembly work to a minimum.

A positive connection is created by tightening the special clamping screws. The smooth contour transitions are pleasant to the touch and ensure enhanced safety.



Industrial stairs and working platforms

General information/
Operation conditions from page 248

Internal tension system from page 252

Quick change system from page 262

Accessories from page 268

ITAS

Industrial stairs and working platforms

...no drilling or welding, no mitre cut – just assemble.



Internal tension system

Principle: The clamping rocker is tilted by screwing in the set screw. The other side of the clamping rocker pushes the pressure piece against the inner side of the tube. Without the need for any mechanical machining, the tube construction is positively and quickly connected by simply tightening a screw.

Clamping set including clamping screw, clamping rocker, thrust pad and screw cap



Quick change system

Working and machining areas which in the past required additional guards can now be made accessible with just a few flicks of the wrist and without the need for any tools thanks to the ITAS quick change system. This makes the complicated removal of entire rail segments a thing of the past.



Features:

- Connect tubes without annoying transitions
- No mechanical treatment required – just cut the material to length and assemble
- Flexible – elements can be dismantled at any time
- Simple and stable system
- Plan and assemble – it's as simple as that!

Options:

- Other surface colours are available on request



Table of contents

Properties/performance data	Technical data p. 250
	Loads / System description p. 250
	Building regulations p. 251
Versions (Dimensions, code numbers)	Internal tension system p. 252
	Quick change system..... p. 266
	Fax request form p. 277
Accessories	Aluminium tube p. 269
	Surface element support p. 269
	Stair railing support TGHF p. 270
	Stair cross beam profile p. 271
	Step profile p. 272
	Side plate p. 273
	Stair joint p. 274
	Stair corner joint p. 275
	Tools/spare parts..... p. 275

Technical data

Basic information / mechanical properties

- ITAS die-cast elements clamping mechanism inside from steel (zinc plated)

Loads

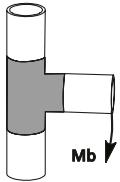

Bending moment Mb [Nm]

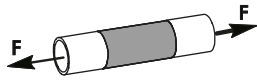

Adh. force: static pull, dynamic pull+pressure

Size Type	Including static safety factor $v = 2,5$		Including dynamic safety factor $v = 1,5$	
	F [N]	Mb [Nm]	F [N]	Mb [Nm]
FI 40	1250	340	1200	160
MI40	1250	340	1200	160
WI40	1250	200	1200	160
WIT40	1250	200	1200	160
WIE40	1250	200	1200	160
WITE40	1250	200	1200	160

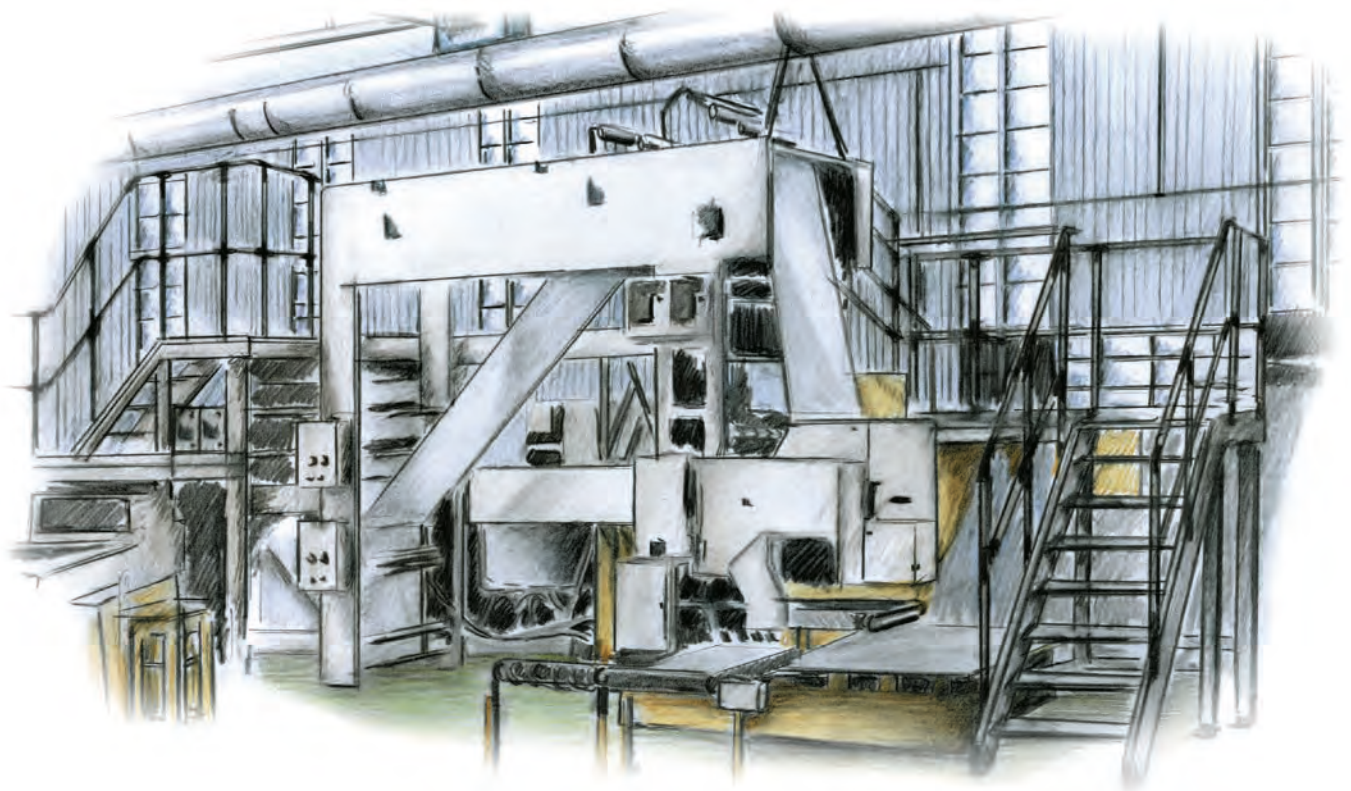

ITAS – Load data

- Load data according to DIN EN 1991-1-1:2010-12
- Maximum permitted load of steps (for a length of 1,2 m) 1500 N
- Maximum permitted load of stairs cross beams (for a 45° angle and a length of 4 m without support) 3500 N
- Maximum permitted load of railing (distance between pillars 0,7 m) 500 Nm
- The maximum permitted load of the platform depends on the base construction. It cannot exceed the maximum permitted load of the base clamps used.
- **Technical safety requirements in accordance with DIN EN ISO 14122 part 1-4**

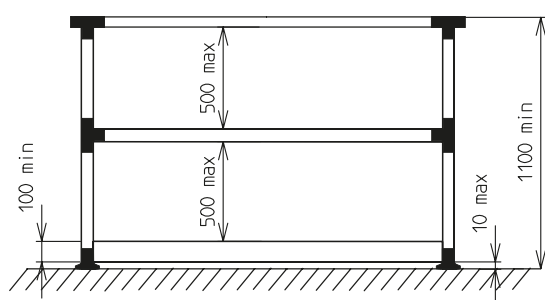

Example for a horizontal railing

- The railing must have at least one knee rail
- Do not exceed a free space between the handrail and knee rail and foot rail of 500 mm
- Fit a foot rail with a minimum height of 100 mm maximum 10 mm above the step level

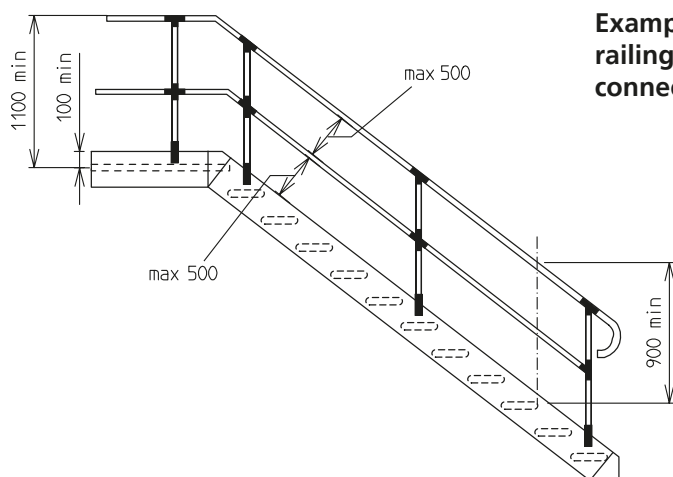

Example for a stair railing - catwalk connector

- A staircase must have at least one handrail
- With a flight width equal to or exceeding 1200 mm two handrails must be provided in the same manner as with all ladder stairs.

Building regulations for railings according to UVV, VBG1 and conforming to DIN EN ISO 14122-3.

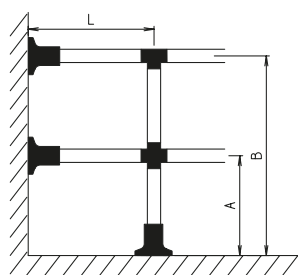

Example 1:
wall and floor fixing

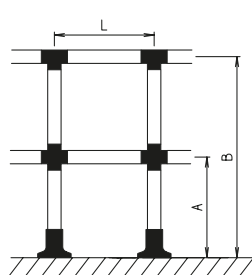

Example 2: self-sup-
porting with floor fixing

[mm]

Example	Dimension max.		
	A	B	L
1	500	1000	1500*
2	500	1000	1500*

* The support spacing "L" must ensure that 340 Nm for base type FI40 is not exceeded.

Internal tension system

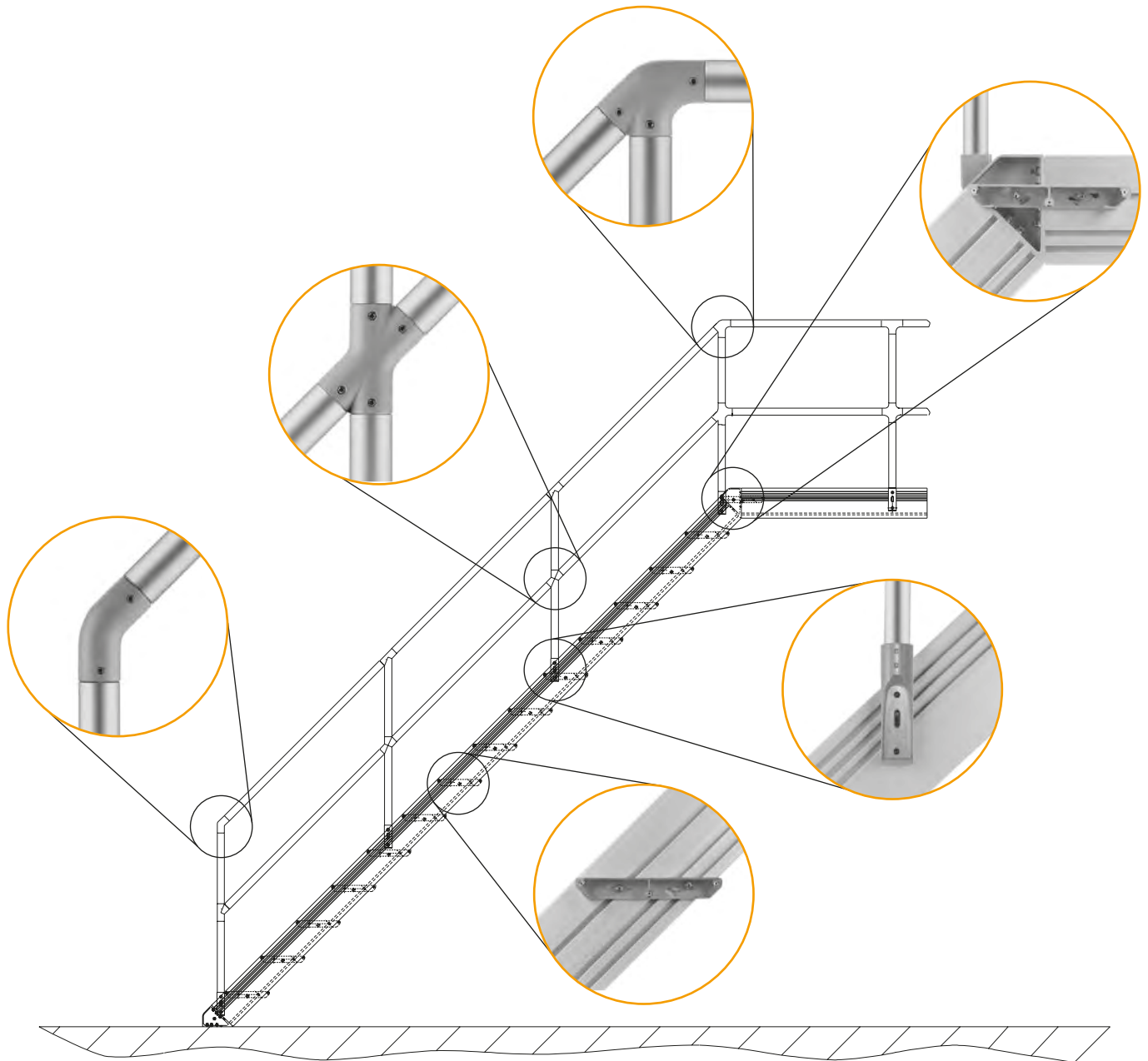

Features:

- Technically optimised solution for the installation of railings, frame structures, boundaries, superstructures, stairs and working platforms of all kinds.
- The smooth transitions between all of the elements used and the connecting tube are kind on the hands
- Positive, quick connection with the simple tightening of a screw – without the need for any mechanical machining



MI 40



KI 40



KI 40H-45°



WIY 40-45°



WI 40



WI 40-45°
30°, 38°, 52°, 60°



WIT 40H-45°R



FIW 40



WIT 40



WIT 40-45°



WIT 40H-45°L



FI 40



WIE 40



WIT 40H-45°



WIV 40H-45°



TSI



WITE 40



KI 40-45°



WIV 40-45°



TSI 40-WI



MIG 40 RR



MIG 40 RZ



MIG 40 ZZ



TGHF

ITAS

Internal tension system

On request:

- ITAS elements in various RAL colours

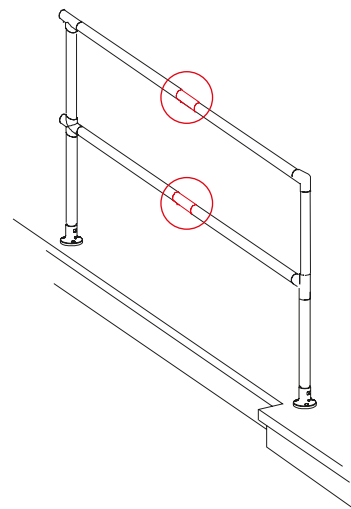
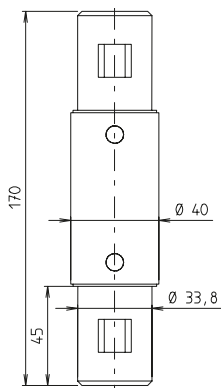

Coupler MI 40

Code No.	Type	m [g]
14403410025	MI 40	453

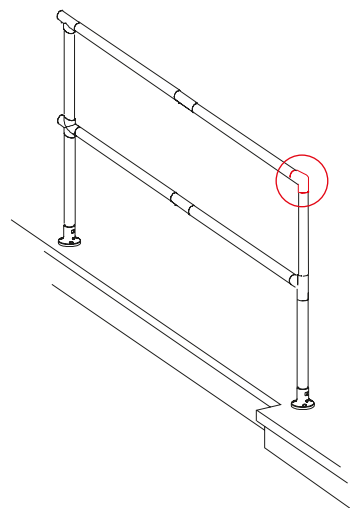
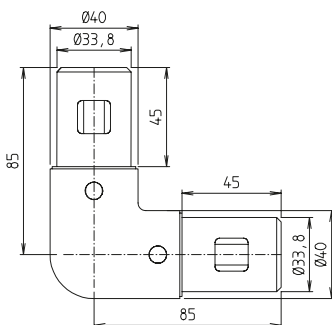

Elbow 90° WI 40

Code No.	Type	m [g]
11403421025	WI 40	455

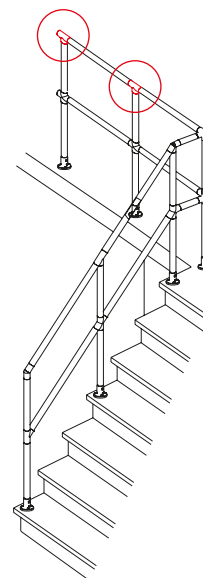
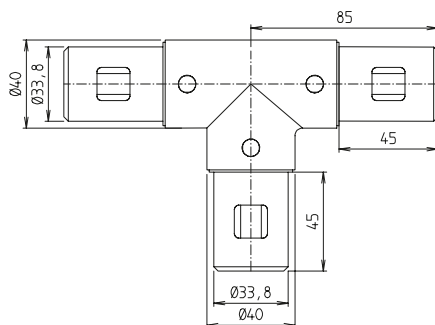

T-joint 90° WIT 40

Code No.	Type	m [g]
11403423025	WIT 40	625

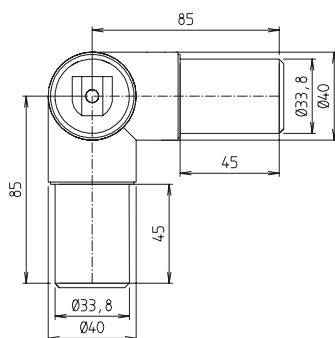

Corner joint WIE 40

Code No.	Type	m [g]
11403422025	WIE 40	624

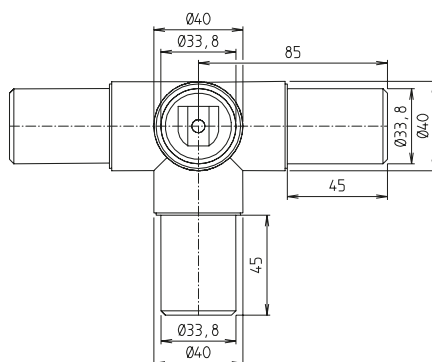
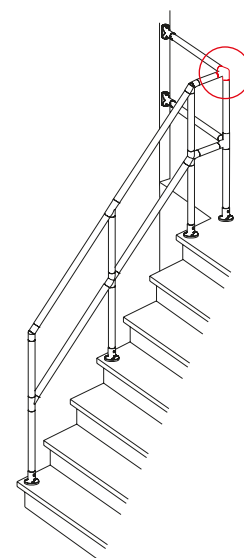

Corner T-joint WITE 40

Code No.	Type	m [g]
11403424025	WITE 40	786

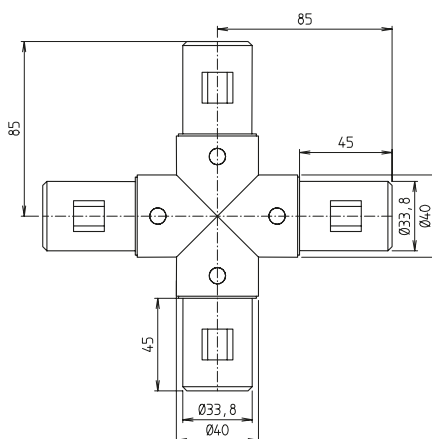
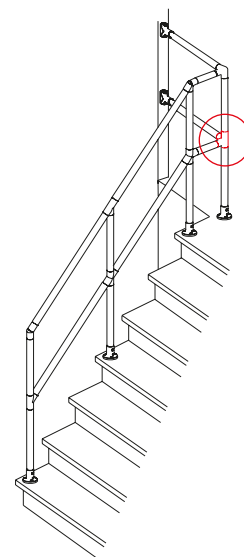

Cross KI 40

Code No.	Type	m [g]
10403410025	KI 40	795

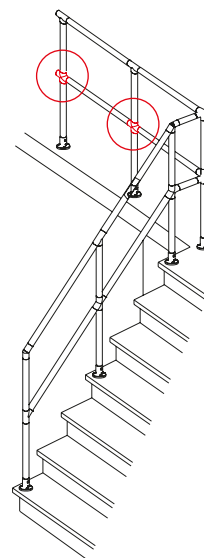

ITAS

Internal tension system

On request:

- ITAS elements in various RAL colours



Elbow WI 40

Code No.	Type	A	B [mm]	m [g]
11404521025	WI 40-45°	135°	95	520
11405021025	WI 40-30°	150°	85	456
11404221025	WI 40-38°	142°	85	456
11402821025	WI 40-52°	128°	85	455
11402021025	WI 40-60°	120°	85	455

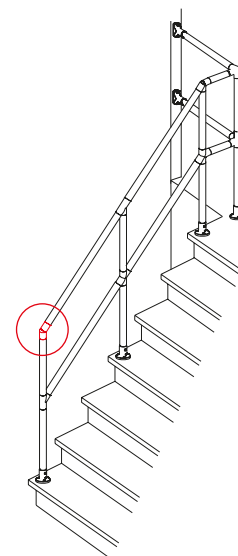
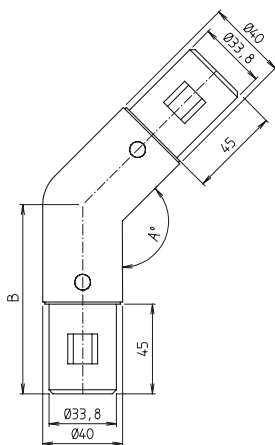

T-joint 45° WIT 40-45°

Code No.	Type	m [g]
11404523025	WIT 40-45°	715

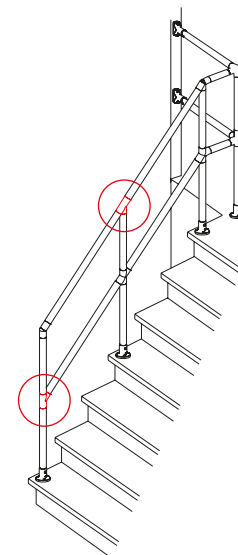
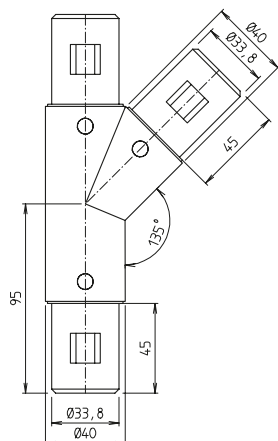

T-joint horizontal 45° WIT 40H-45°

Code No.	Type	m [g]
11404525025	WIT 40 H-45°	715

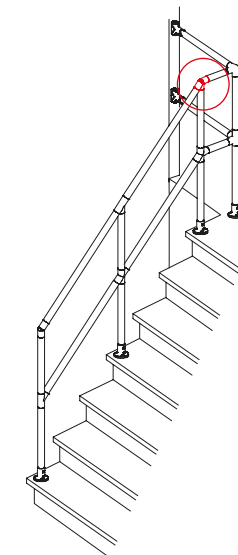
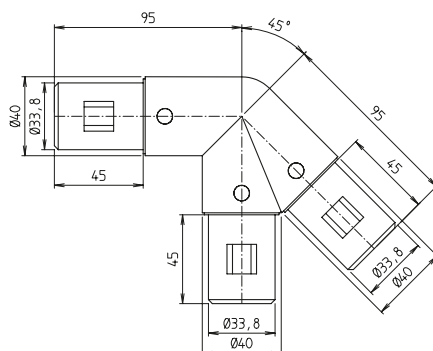

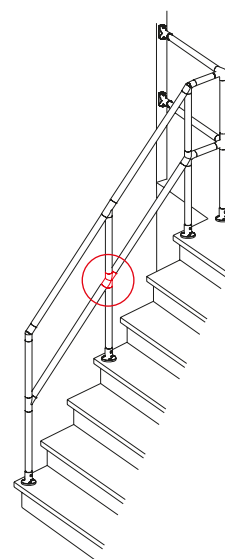
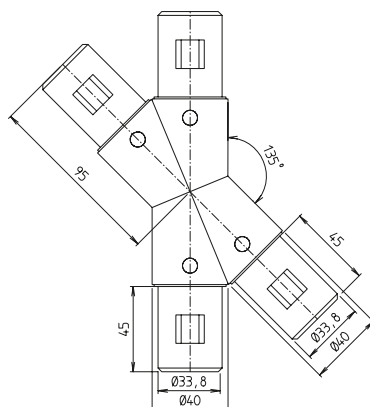

Cross KI 40-45°

Code No.	Type	m [g]
10404510025	KI 40-45°	901

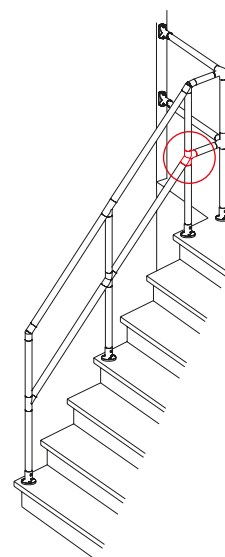
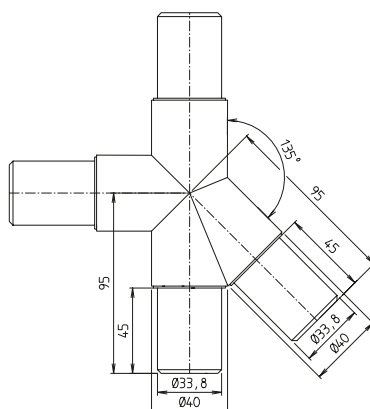

Cross horizontal KI 40H-45°

Code No.	Type	m [g]
10404521025	KI 40 H-45°	940

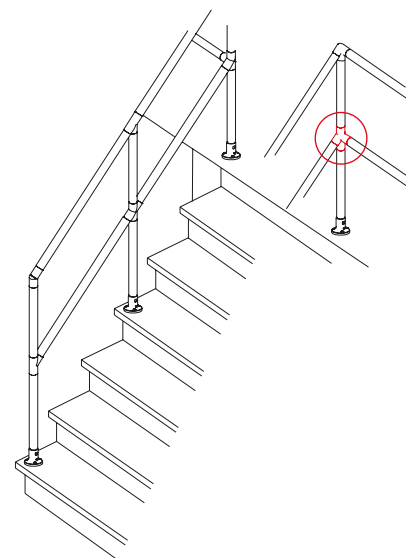
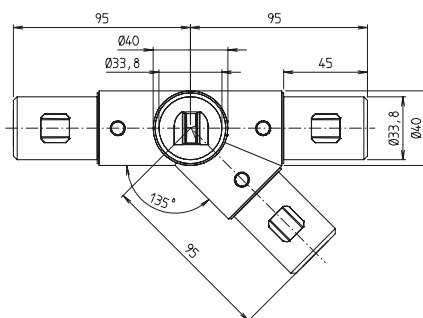

WIT 40H-45°R

Code No.	Type	m [g]
11404528025	WIT 40H-45°R	908

ITAS

Internal tension system

On request:

- ITAS elements in various RAL colours

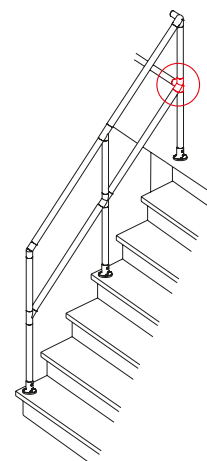
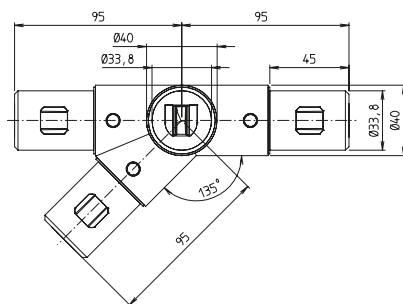

WIT 40H-45°L

Code No.	Type	m [g]
11404529025	WIT 40H-45°L	903

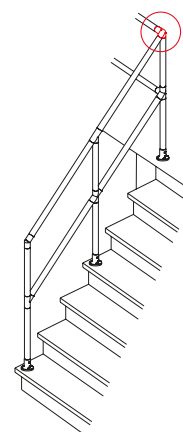
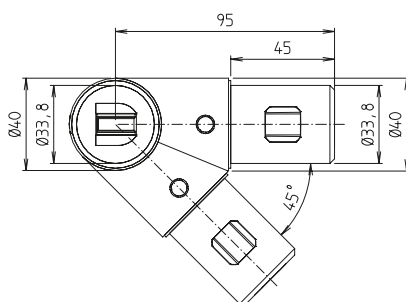

WIV 40H-45°

Code No.	Type	m [g]
11404527025	WIV 40H-45°	693

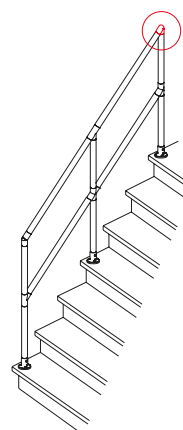
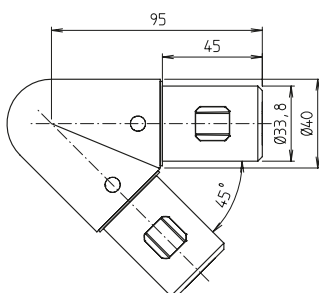

WIV 40-45°

Code No.	Type	m [g]
11404526025	WIV 40-45°	486

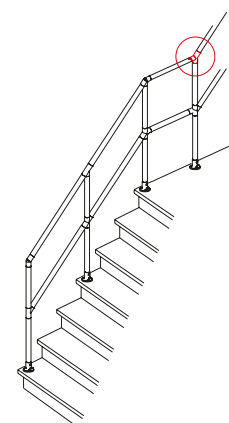
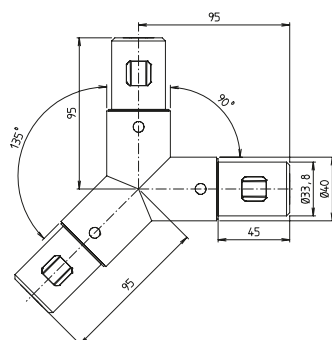

WIY 40-45°

Code No.	Type	m [g]
11404530025	WIY 40-45°	733



MIG 40 RR

Code No.	Type	m [g]
18403456025	MIG 40 RR	261

With tothing – 180° swivelling range, 15° locking increments
 Tothing can be removed for continuously variable adjustment

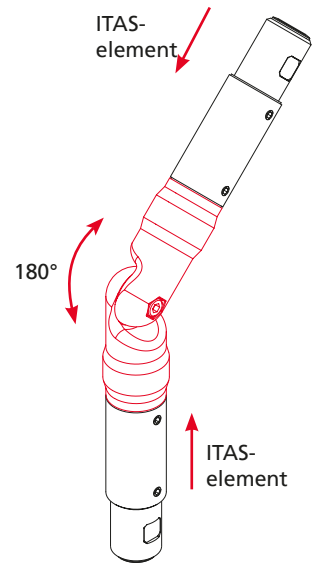
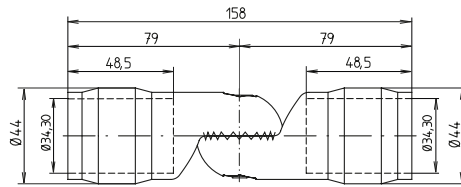

MIG 40 RZ

Code No.	Type	m [g]
18403455025	MIG 40 RZ	374

With tothing – 180° swivelling range, 15° locking increments
 Tothing can be removed for continuously variable adjustment

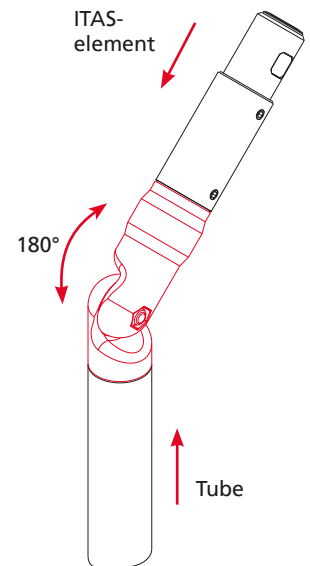
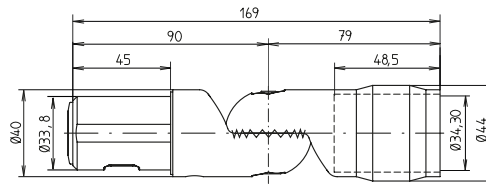

MIG 40 ZZ

Code No.	Type	m [g]
18403457025	MIG 40 ZZ	483

With tothing – 180° swivelling range, 15° locking increments
 Tothing can be removed for continuously variable adjustment

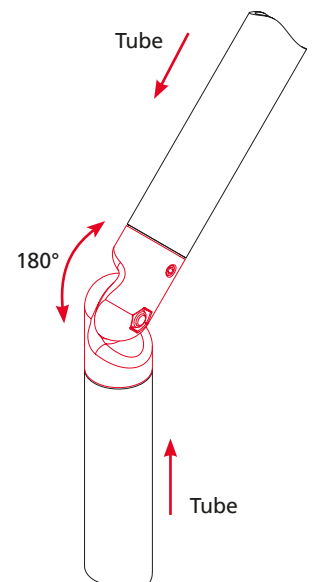
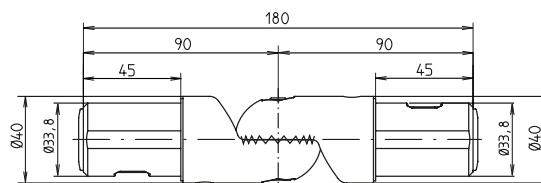

Internal tension system

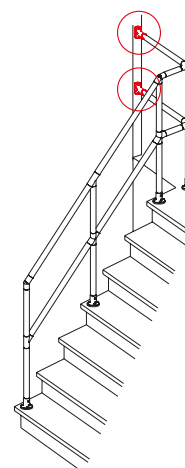
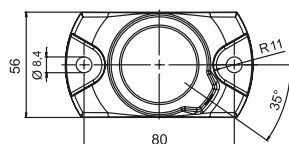
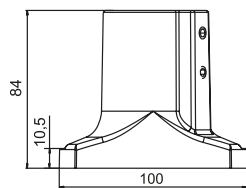

FIW 40 (Wall flange)

Code No.	Type	m [g]
13403430025	FIW 40	428

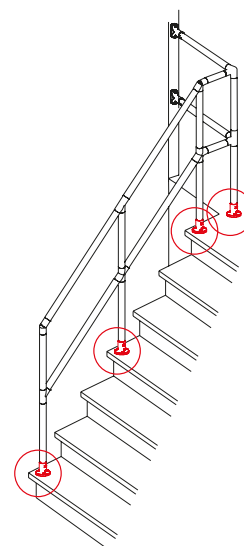
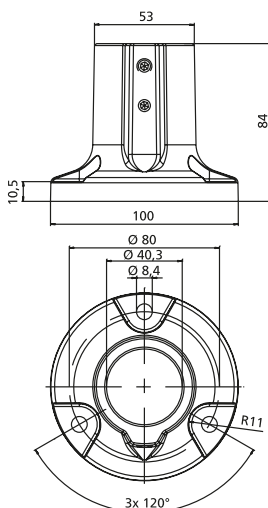

Base FI 40

Code No.	Type	m [g]
13403431025	FI 40	487



Insert depth

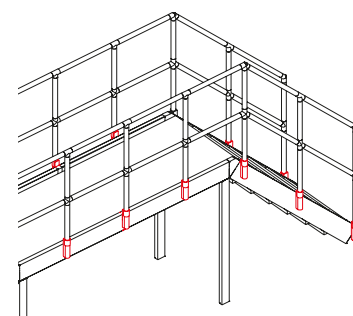
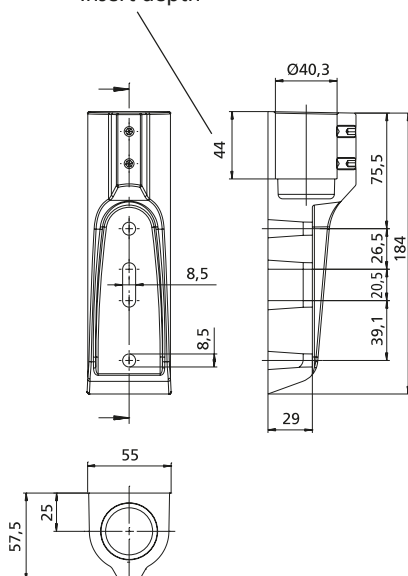

Stair railing support TGHF

Code No.	Type
13403429025	TGHF 40
93800	fitting TGHF cross beam profile

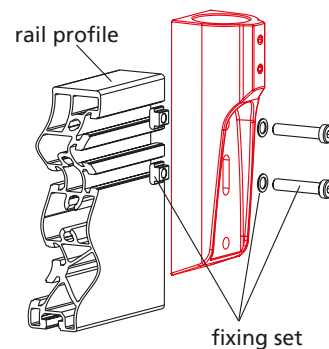



On request:

- ITAS elements in various RAL colours

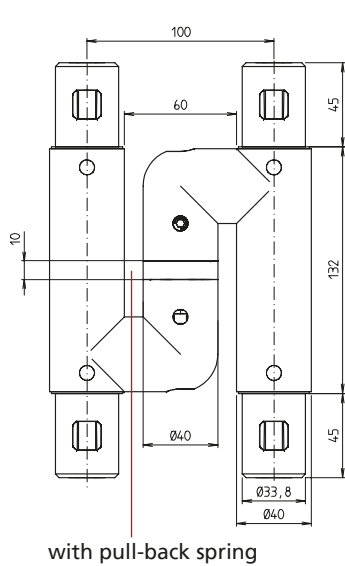

with pull-back spring

spring-return

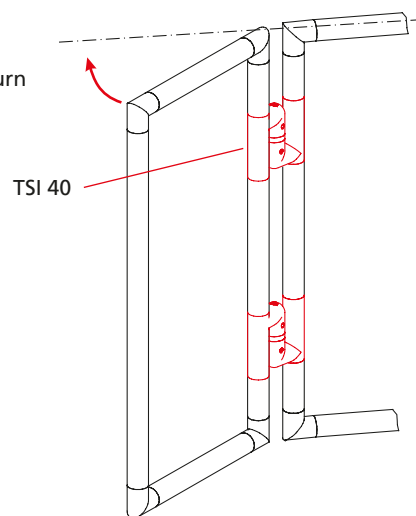
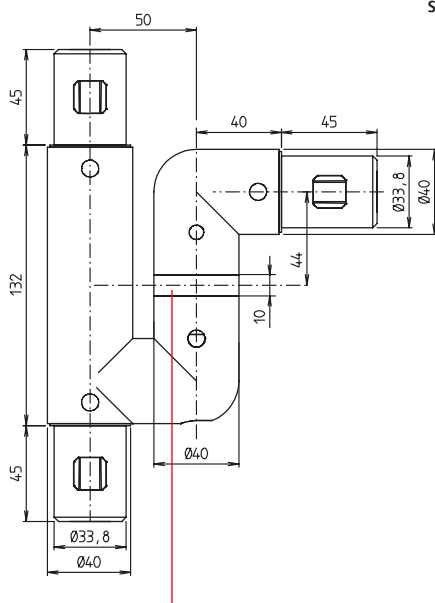

Illustration shows right hand version

TSI 40

Code No.	Type	Version	m [g]
18403426025	TSI 40	Right-hand	1872
18403427025	TSI 40	Left-hand	1849

Attention: please read the instruction manual



with pull-back spring

spring-return

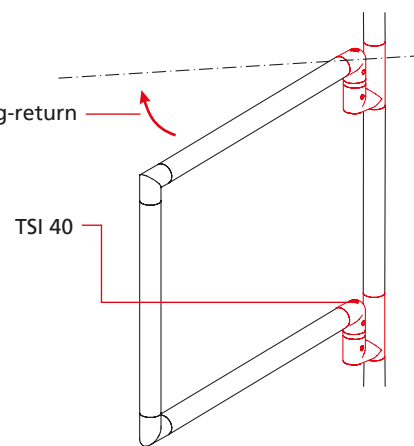

Illustration shows right hand version

TSI 40-WI

Code No.	Type	Version	m [g]
18403428025	TSI 40-WI	Right-hand	1353
18403429025	TSI 40-WI	Left-hand	1389

Attention: please read the instruction manual

Quick change system

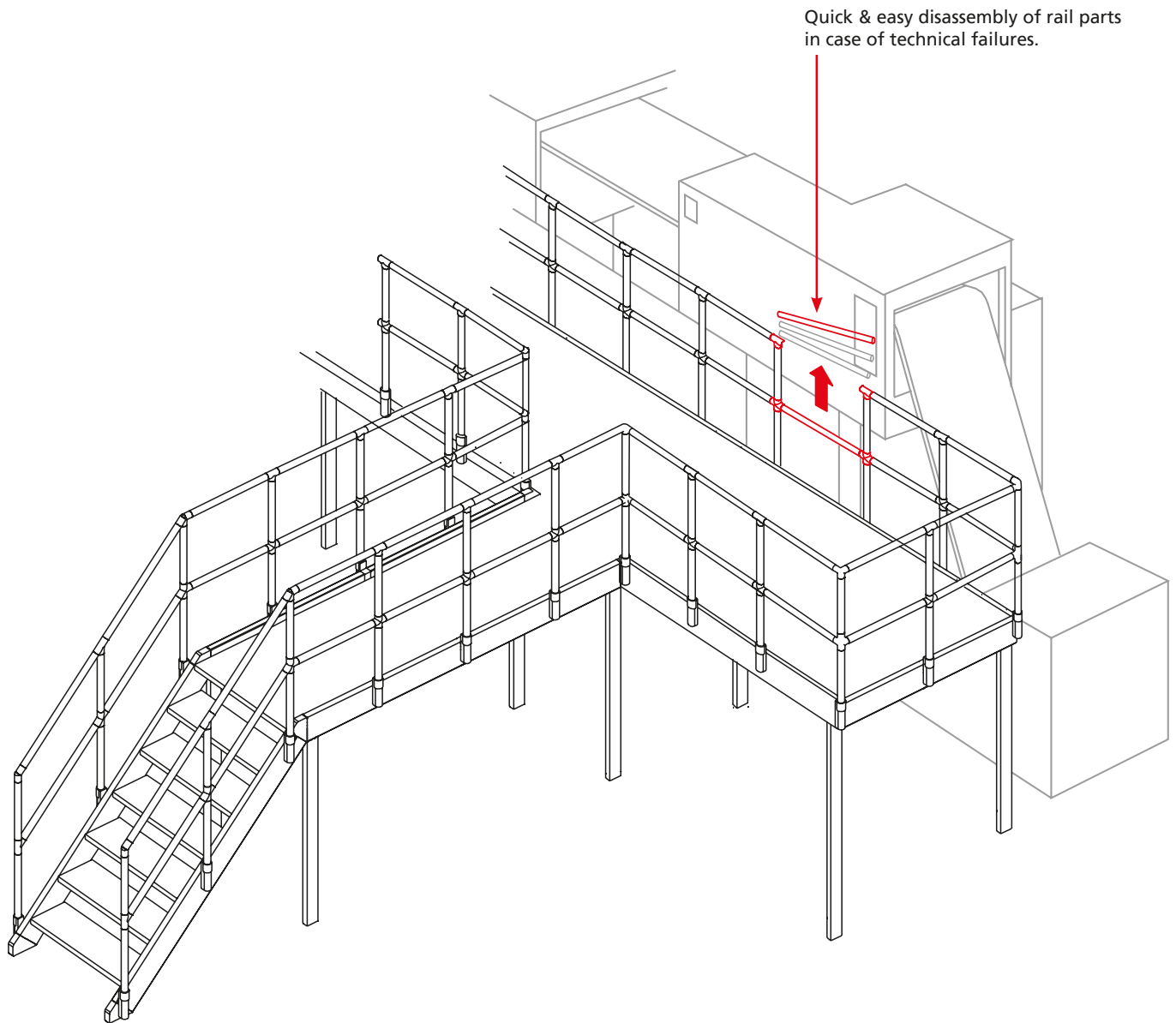

Features:

- This system combines the proven flexibility of the internal tension system and an easy assembly and dismantling system which cannot be compared to that of common railing systems.
- It enables protected working and machine areas to be more accessible.
- The new ITAS Quick change system permits an easy access to specific machine parts in case of technical malfunctioning: all you need is to remove the necessary part of the balustrade.



WI 40-SW1



KI 40H-45°SW1



KI 40-SW2



WIT 40-SW1



WIT 40-SW2



WIT 40H-45°SW1



WIE 40-SW2



WITE 40-SW2

Dismantling of quick change system



Release stopper with a screwdriver



Loosen clamping screw



Turn the cross strut to 90° and then raise and release



ITAS

Quick change system

On request:

- ITAS elements in various RAL colours

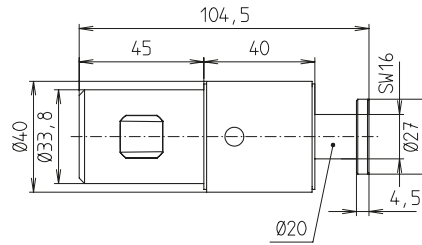

Attention:

The clamping element MI-H 40-SW is included in the delivery set of the following quick change elements. This element does not need to be ordered separately

MI-H 40-SW

Code No.	Type	m [g]
14403411025	MI-H 40-SW	307

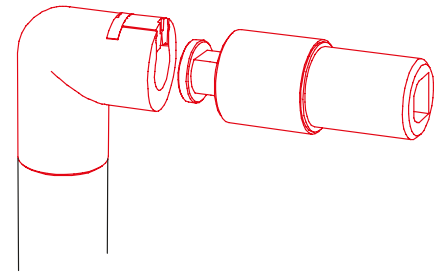
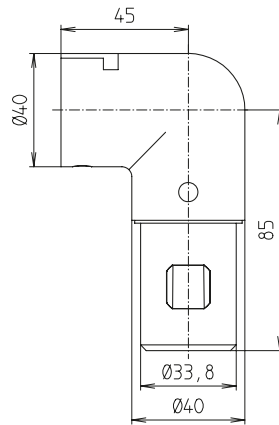

WI 40-SW1

Code No.	Type	m [g]
11403425025	WI 40-SW1	643

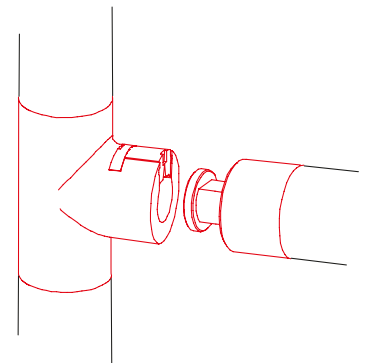
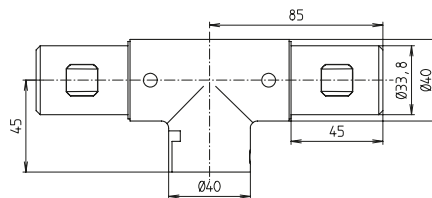

WIT 40-SW1

Code No.	Type	m [g]
11403428025	WIT 40-SW1	828

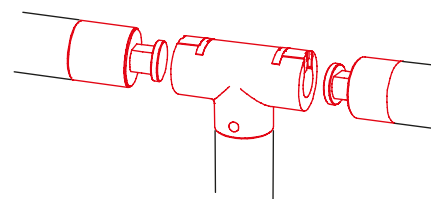
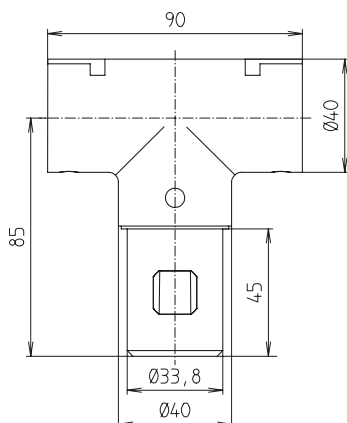

WIT 40-SW2

Code No.	Type	m [g]
11403426025	WIT 40-SW2	1020

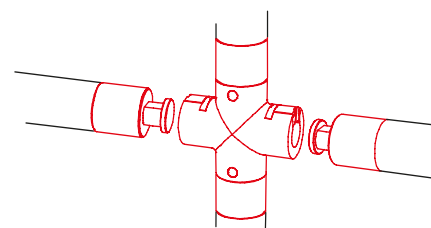
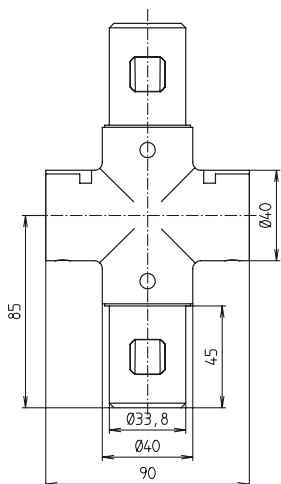

KI 40-SW2

Code No.	Type	m [g]
10403411025	KI 40-SW2	1221

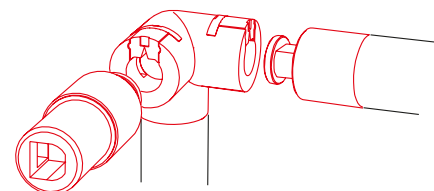
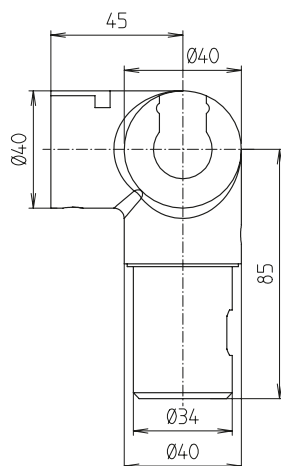

WIE 40-SW2

Code No.	Type	m [g]
11403427025	WIE 40-SW2	1034

ITAS

Quick change system

On request:

- ITAS elements in various RAL colours

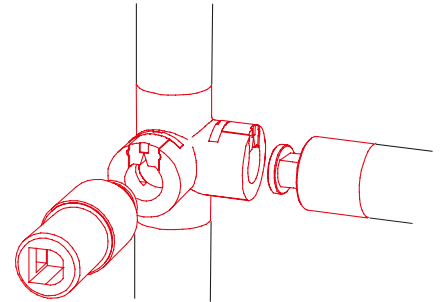
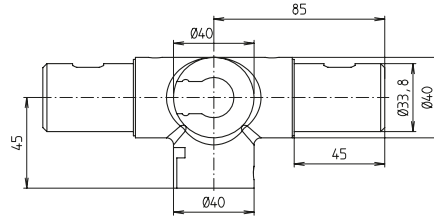

WITE 40-SW2

Code No.	Type	m [g]
11403429025	WITE 40-SW2	1209

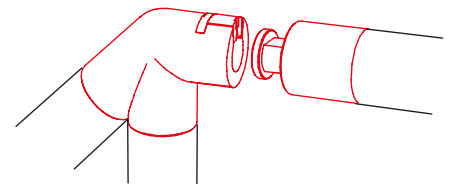
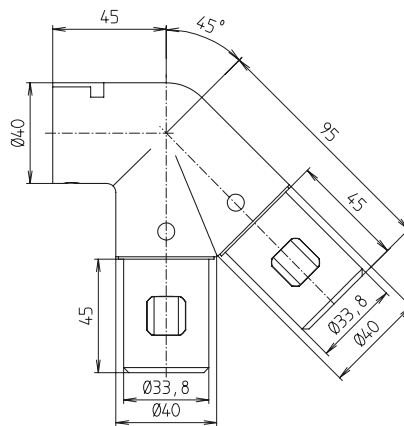

WIT 40H-45°SW1

Code No.	Type	m [g]
11404524025	WIT 40H-45°SW1	902

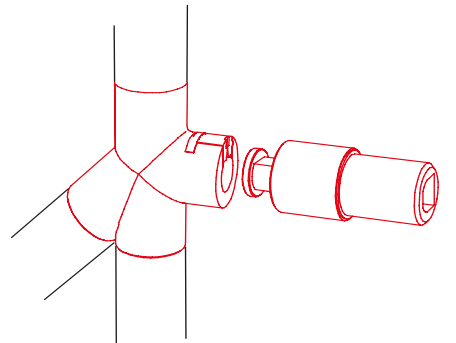
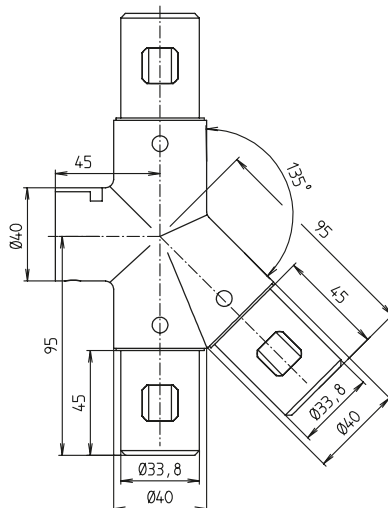

KI 40H-45°SW1

Code No.	Type	m [g]
10404511025	KI 40H-45°SW1	1068



The mobile ITAS ladder makes accessing various storage shelves easier.



Accessories



Aluminium tube
Ø 40x3



Angle plate
TGHF



Side plate



Surface element support
FEH-I 40



Stair cross beam
profile



Stair joint



Step profile



Stair corner joint



Material:
 3.3206/EN AW6063 T66(F25)
 Resistance moment $W = 3 \text{ cm}^3$
 Moment of inertia $I = 6 \text{ cm}^4$

Aluminium tube

Code No.	Type	Version
8240302	40x3	clear anodized
8240303	40x3	black anodized

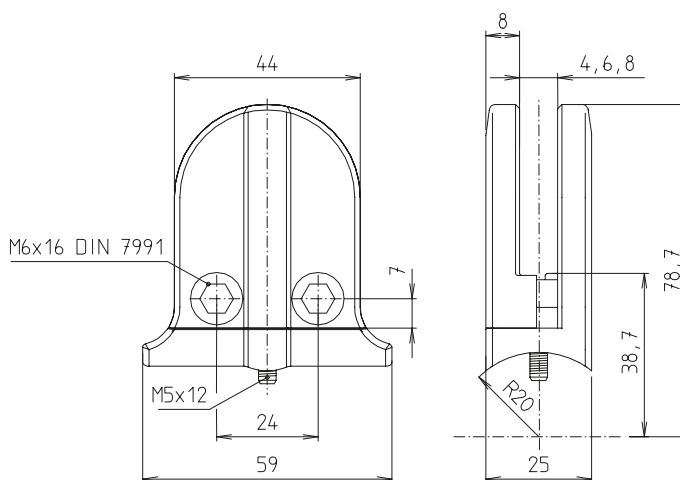
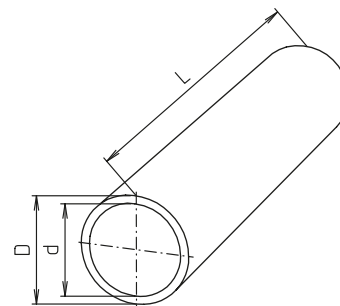
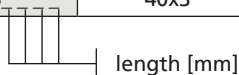

Features:

- The surface element support enables the clamping of panels of 4, 6 or 8 mm thickness.
- The support can be used with a $\text{Ø}40$ tube (min. wall thickness 3 mm)
- Only a 4.5 mm hole has to be bored into the tube where the support is then fixed with a thread former screw.

Material: PA-GF, black
 Fixation set galvanized

FEH-I 40 (Surface element support)

Code No.	Type
91803	FEH-I 40

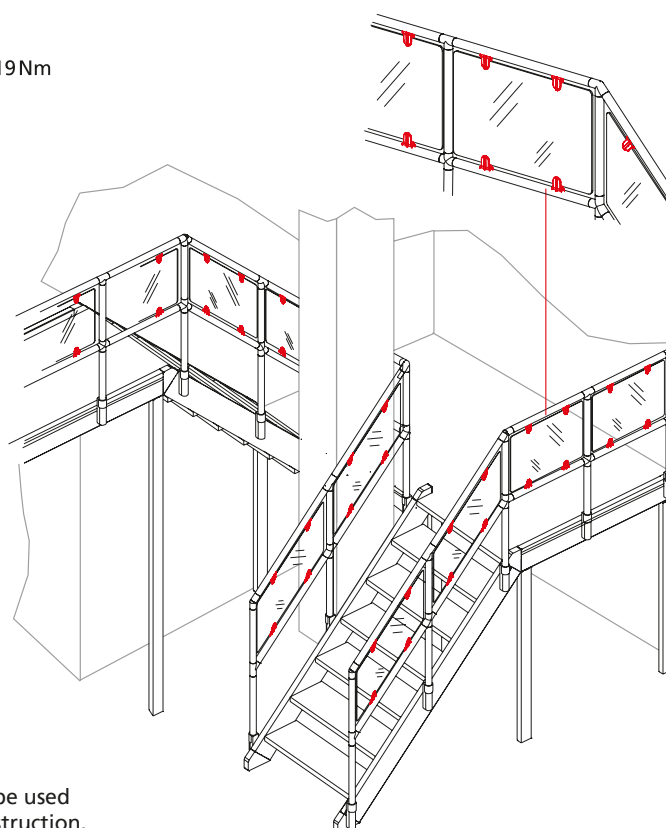
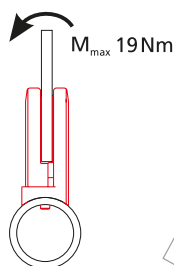

Attention:
 the support can only be used
 in a closed frame construction.

Accessories

On request:

- ITAS elements in various RAL colours

- The angle plate is fixed to the corner of the stair cross beam at 90° degrees.

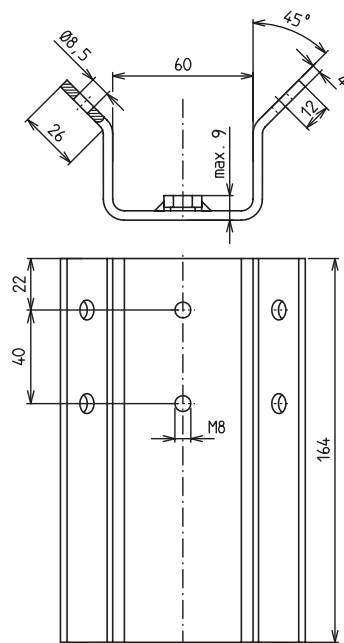
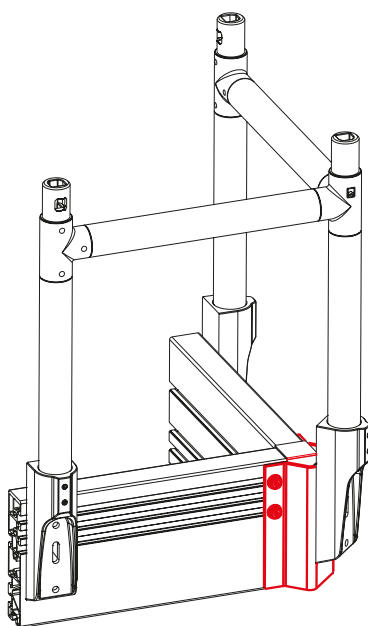

Angle plate for TGHF

Code No.	Type
96701	Angle plate



Material: AlMgSi 0,5 F25,
clear anodized

$I_x = 37 \text{ cm}^4$
 $I_y = 606 \text{ cm}^4$
 $W_x = 18 \text{ cm}^3$
 $W_y = 69 \text{ cm}^3$

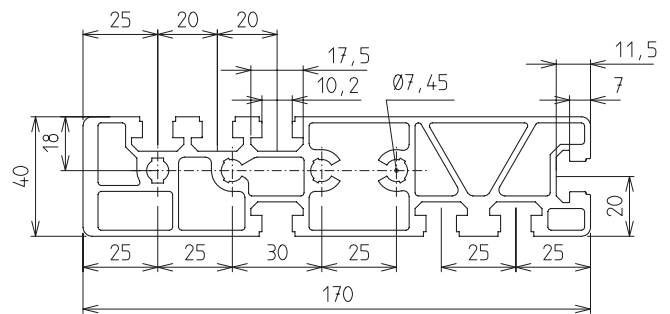

Stair cross beam profile

Code No.	Type	Version	m [g]
4505000	Stair cross beam profile	Cut max. 6000 mm	5957 / m
4505001	Stair cross beam profile	Bar at 6000 mm	5957 / m

Features:

- The 'T'-slot channels of the extruded aluminium profile enable fitting of the fixing components for the step profile (see p. 272).
- The geometry of the 'T'-slot channels is designed to comply with the BLOCAN® Profile Assembly System which is designed and manufactured by RK Rose+Krieger.
- Threaded holes ensure that the stair joints (see p. 274) can be fixed with set screws quality 8.8
- Realisation of 38, 45 and 60 degree leadangles without mitre cuts of the beam profile by using special designed stair joints. Saws with a smaller disc dia can therefore be used.
- The geometry conforms with the UVV rules so that commercially available surface elements / grids can be used for the platform surfaces
- The protective railing and the continuous rim of the stair cross beam profile provide protection against slipping.

Accessories



Material: AlMgSi 0,5 F22, natural

$I_x = 16 \text{ cm}^4$
 $I_y = 1003 \text{ cm}^4$
 $W_x = 7 \text{ cm}^3$
 $W_y = 80 \text{ cm}^3$

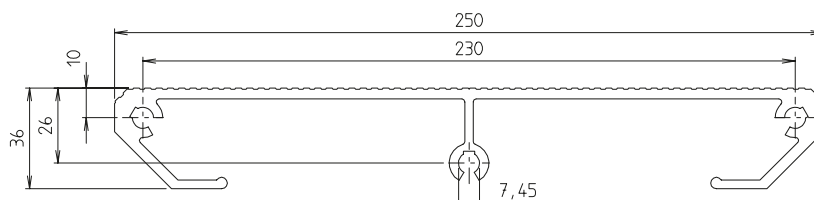
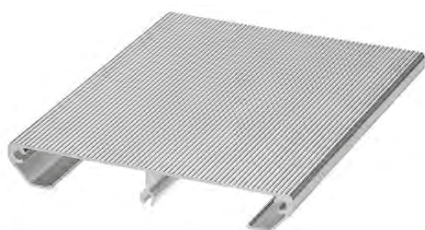

Step profile

Code No.	Type	Version	m [g]
4525000	Step profile	Cut max. 6000 mm	3621 / m
4525001	Step profile	Bar at 6000 mm	3621 / m

Features:

- An endless step profile made of extruded aluminium which is cut to the step width desired.
- All stairs with a gradient angle of between 30 and 40 degrees are in accordance with standard DIN EN ISO 144122-:201610. This includes treads, height, overlap and width. They are also compliant with UVV (workers safety regulations and accident prevention rules).
- Threaded channels have been prepared to ensure thar side plates can be fixed with standard M8 screws see p. 251).
- This step profile can, of course, also be used as a platform element.

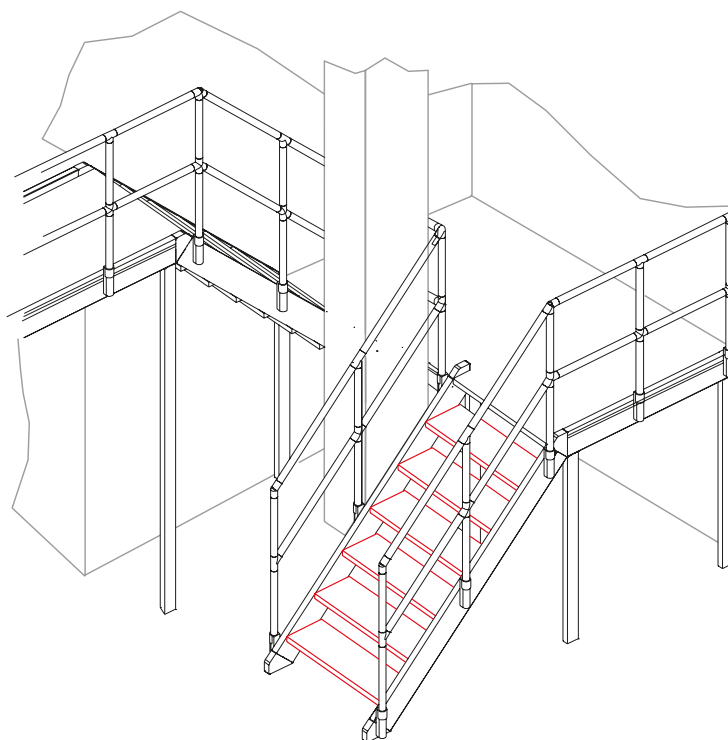



Features:

- The code n° contains a complete fixing set for the fitting of the side plate to the step profile (see p. 250).
- The arrangement of the holes and slots enables alignment of the step when it is fitted to the stair cross beam profile. The side plate serves as an end piece to the step width chosen by the customer.

Material: AlMgSi 0,5 F22, natural

Thickness t = 5 mm

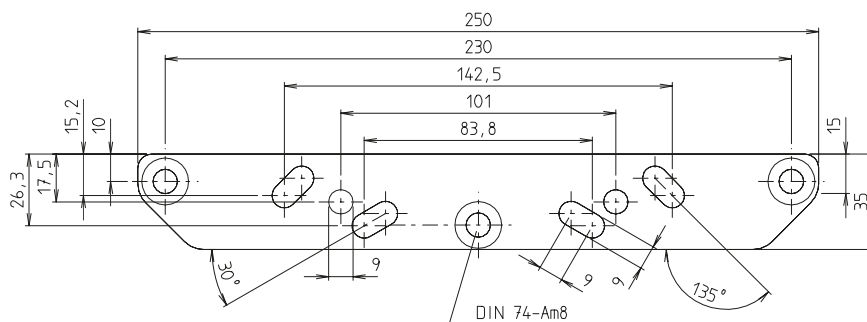

Site plate

Code No.	Type	m [g]
93700	Side plate	164

Accessories

Features:

- This joint permits the construction of 38°, 45° and 60° angles.
- The arrangement of holes guarantees the fixing of this joint to the stair cross beam profile (see p. 249) with set screws quality 8.8 and hexagonal nuts.
- The centre spigot is for the fixing of the last step in the transition from stair to platform.



Fixing stairs / floor with stair joint 45°



Fixing stairs / floor with mitre cut 38°, 60°



Fixing stairs / working platform with stair joint 38°, 45°, 60°

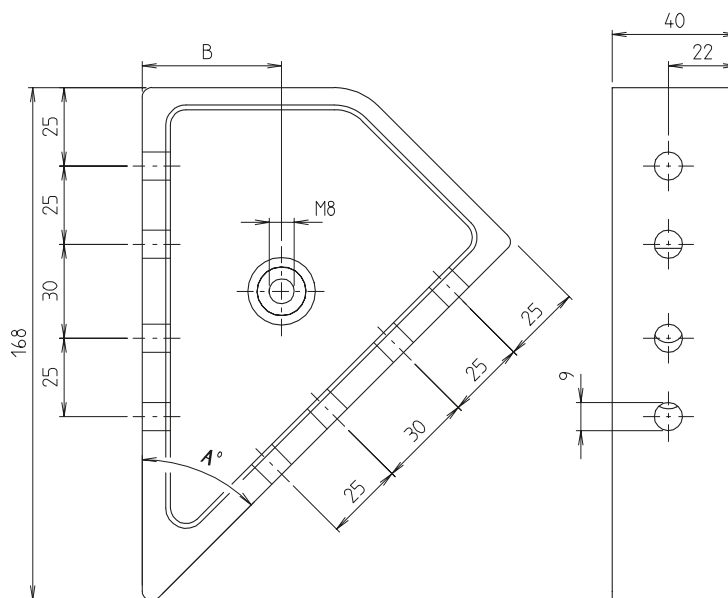

Stair joint

Code No.	Type	A	B	Material	m [g]
93807	Stair joint 38° fixing step-platform	38°	36,15	Gk AlSi 12	436
93810	Stair joint 45° fixing step-platform	45°	44,5	Gk AlSi 12	500
93811	Stair joint 45° fixing floor step	45°	44,5	Gk AlSi 12	500
93820	Stair joint 60° fixing step-platform	60°	60,5	Gk AlSi 12	563



Order instruction:

- Purchase only in lot sizes and a multiple of that, see product table below

Material: AlMgSi 0,5 F22

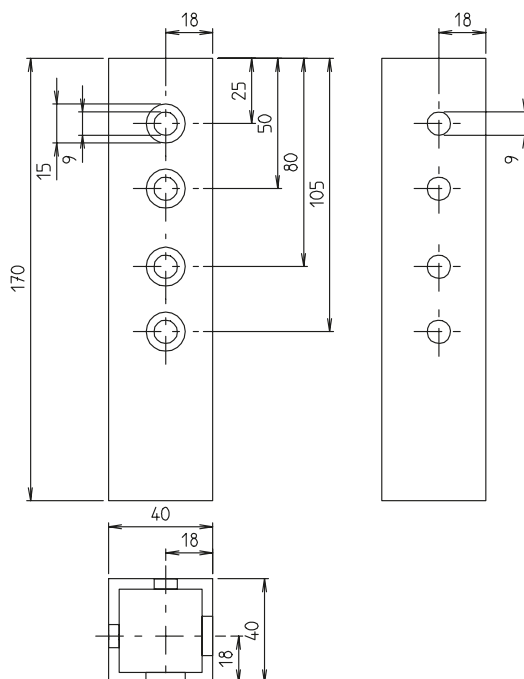
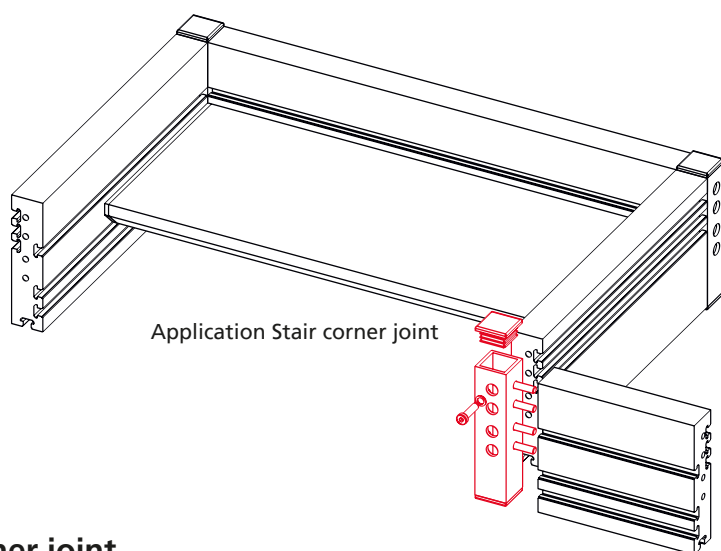

The illustration shows a "left" version . The right version is the mirror-image.

Stair corner joint

Code No.	Type	m [g]
93821	Stair corner joint right-hand	242
93822	Stair corner joint left-hand	242

Tools

Code No.	Type	lot sizes	Application
91804	Compl.clamping lever set	-	Spare parts for internal tension system (clamping screw, clamping rocker, thrust pad, screw cap)
90404	Stopper	10, 20, 30... pcs	for quick change system

Industrial stairs and working platforms



A circulating podium, in an assembly hall, with multiple access points.



Staircase between two operating platforms.



Enquiry form ITAS – Industrial stairs and working platforms

Fax: 49 571 9335-139 Phone: 49 571 9335-0
e-mail: anfrage.vertrieb@rk-online.de

Company:..... Customer no:.....
 Adress:
 Phone:..... Telefax:.....
 Responsible:..... E-Mail:
 Remarks:

Working platform

Constructions are made of aluminium components with non-slip step profiles and smooth connections between handrailing components allowing a complete modular design.

Procedure:

Please fill in points 1 to 4, so that we are able to send you the quotation as soon as possible.
 A layout of your details with possible constructional suggestions from our company will be placed at your disposal upon request.

1. Application

fixed platforms

2. Delivery

unassembled

pre-assembled parts

3. Technical data

Load: max. 150 kg/m²

Step width:mm

Length of platform:mm

Height of platform:mm

Angle of inclination (see type of railing) ⇒

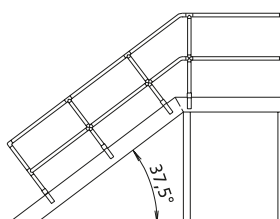

Railing 38°

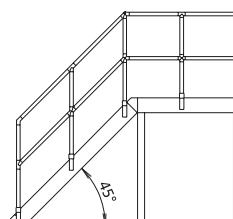

Railing 45°

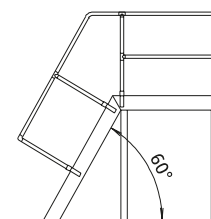

Railing 60°

4. Angle of inclination (see type of railing)

Stairs

Railing*

Stairs mit platform

Railing*

Bridge

Railing*

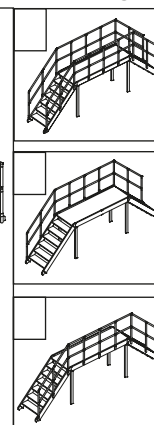
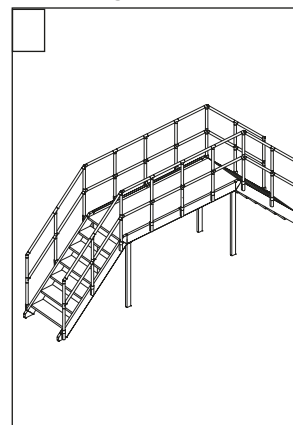
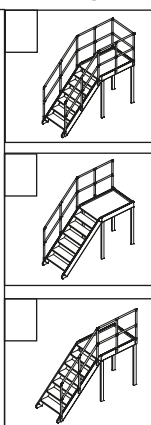
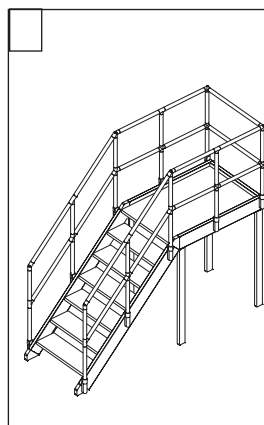
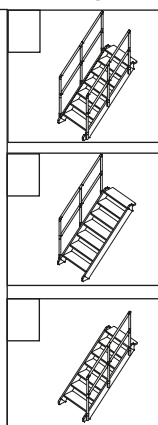
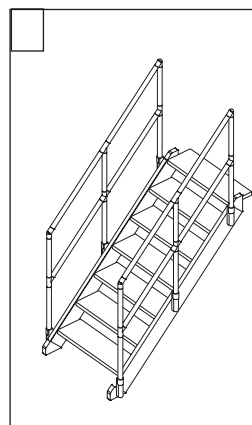

*In case of a height of more than 1 m it is necessary to assemble railings onto the stairs and platforms.

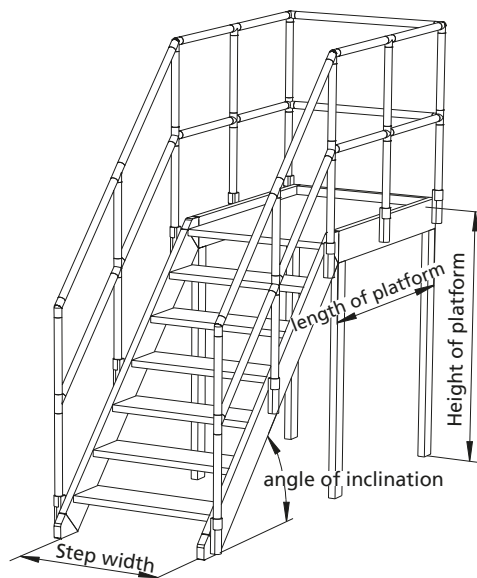

Monitor mounts for industry

Optimal positioning of control units/HMIs (Human Machine Interface)

The monitor mountings from RK Rose+Krieger allow for an optimal view of the monitor or a control panel. The range of action can be increased even further by using a swivel arm. This may be useful for carrying out set-up work on machinery for example, or if the monitor is having a disruptive impact on the working environment.

There is also the option of expanding the support arm with two support tubes (twin version) to include a sturdy keyboard tray.

The modular design of the RK swivel arm/support arm system allows for varied combination options and helps to adapt workstations to the most ergonomic arrangement.



RK Monitor Mounting

Versions	page 284
Fixing	page 292
Modules	page 300
Accessories	page 302

RK Monitor Mounting

All purpose mounting for monitors, touch panels and operating units

This mounting for monitors, touch panels and other operating units is flexible, offers many degrees of freedom and thus can be used universally. Due to compatibility to RK Connecting Technology as well to the RK Profile System most different connections are realizable.

Ideal range of applications:

- General industrial applications
- Plants and machines
- Control centers
- Ergonomic work stations

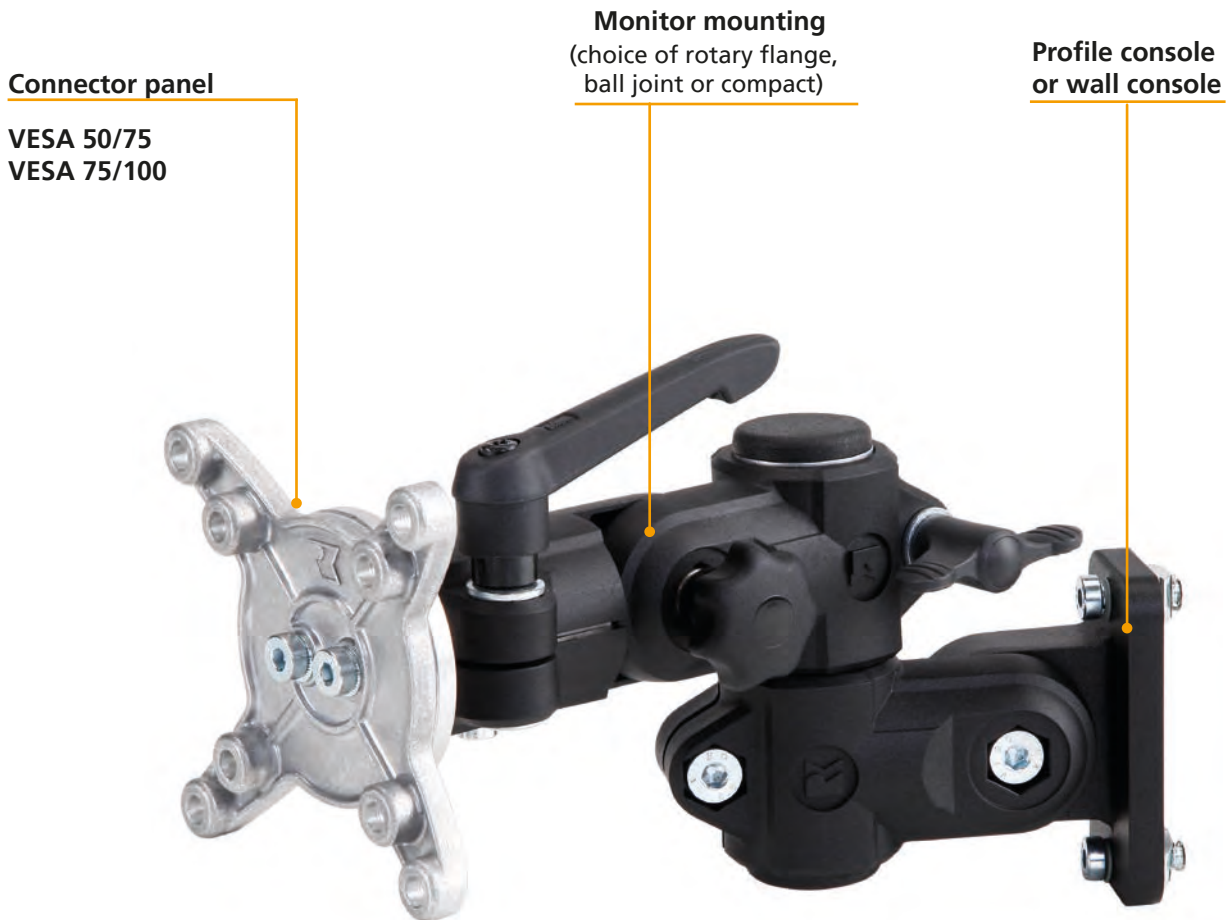

Features

- Choice of user-specific or VESA-standard monitor connection
- High-strength materials guarantee a long-term load-bearing capacity of up to 25 kg, for reliable recesses
- Highly ergonomic thanks to personalised height adjustment
- Optimum adjustment of the field of vision thanks to side-turning
- rotary flange and ball joint: vibration-proof locking in 15° increments
- compact: fixing principle with half shells (suitable for retrofitting and extensions) reducing bushes available (round or square 20, 25, 30mm)
- Connects to aluminium profile, and thus also to the machine frame using slot stones
- Universal mounting holes facilitate simple wall mounting

Table of contents



RK ROSE+KRIEGER

Versions	Rotary flange monitor mounting	S. 282
	Ball joint monitor mounting	S. 282
	Monitor mounting compact	S. 283
	Console monitor mounting	S. 284
	Dual-ball monitor mounting	S. 285
	Dual-ball pivoting monitor mounting	S. 285
Fixing	Wall console	S. 286
	Profile console	S. 286
	Support arm single.....	S. 287
	Support arm double.....	S. 288
	Support arm double height adjustable	S. 289
	Support arm telescope	S. 290
	Support arm telescope height adjustable	S. 292
	Modules	Monitor floor stand adjustable
Monitor floor stand stationary		S. 298
Accessories	Adaptor plate VESA 50/75	S. 306
	Adaptor plate VESA 75/100	S. 306
	Keyboard tray	S. 307
	Notebook holder.....	S.30
	Tablet holder	S. 309
	Smartphone holder.....	S. 310
	Lockable steering roller	S. 311
	Vario-Quick holding block	S. 311
	Reducing bushes.....	S. 312
	Reducing inserts	S. 312
	Clamping lever	S. 313
Cable straps with velcro.....	S. 313	
Applications	Monitor Mounting	S. 302

RK Monitor Mounting

Versions

Rotary flange monitor mounting



Locking in 15° - steps

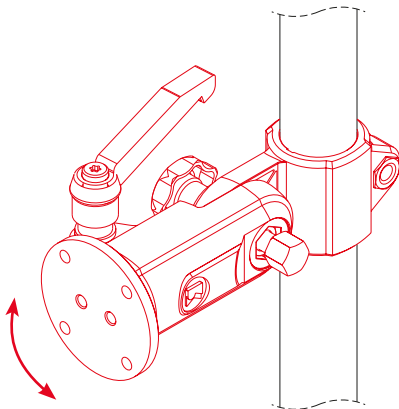
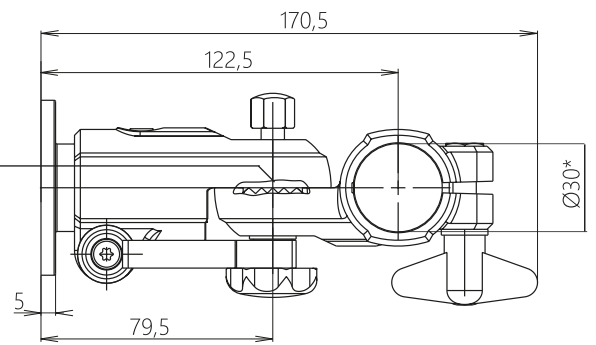

90°

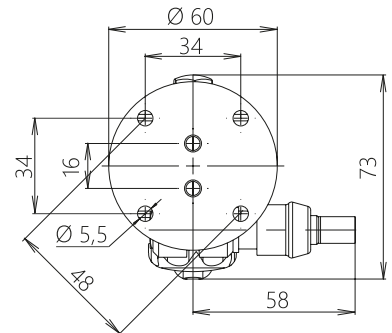

Code No.	Weight	max. load
193000030C11	370 g	25 kg

*Other cross-sections by reducing bushes (see page 312)

Ball joint monitor mounting



Locking in 15° - steps

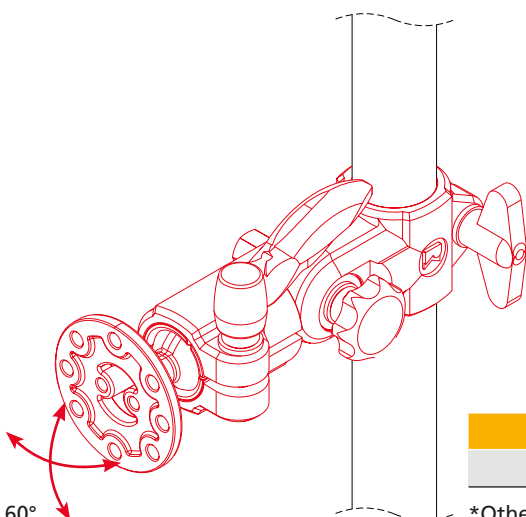
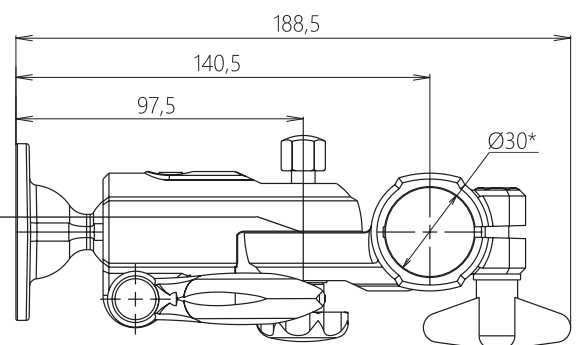

60°

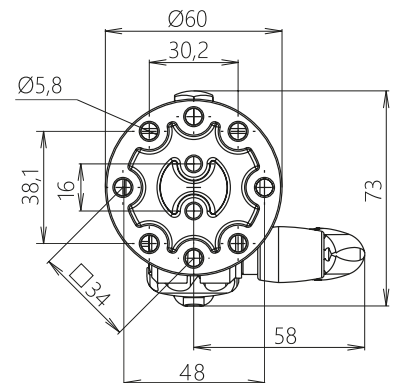

Code No.	Weight	max. load
193000042C11	342 g	10 kg

*Other cross-sections by reducing bushes (see page 312)



Monitor mounting compact

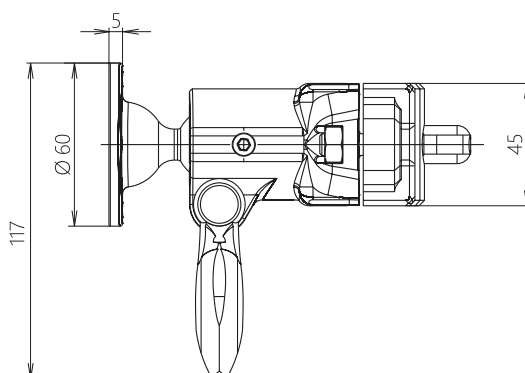
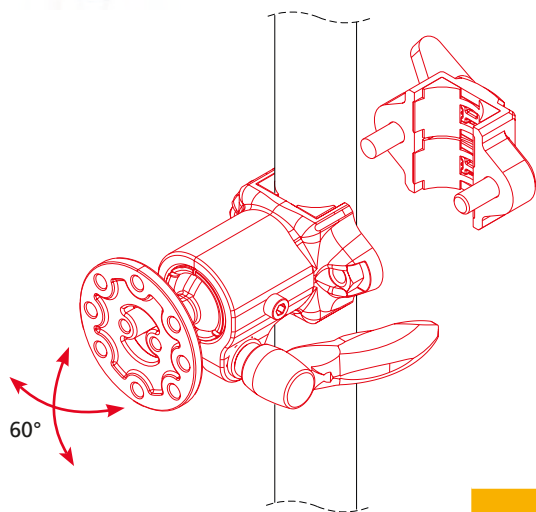
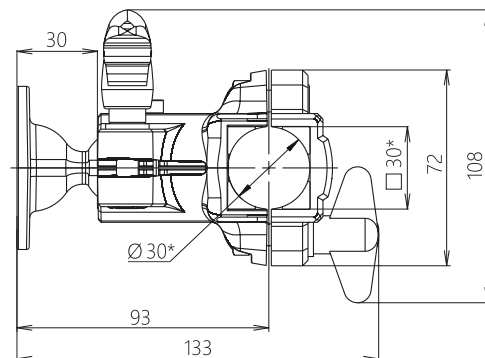
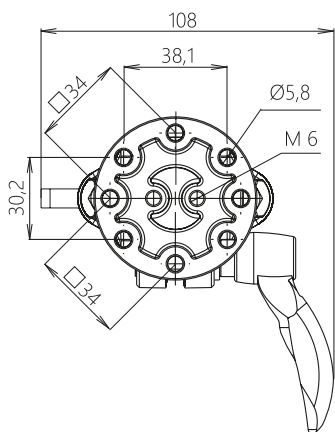

Code No.	Weight	max. load
193000052C11	290 g	10 kg

*Other cross-sections by reducing inserts (see page 312)

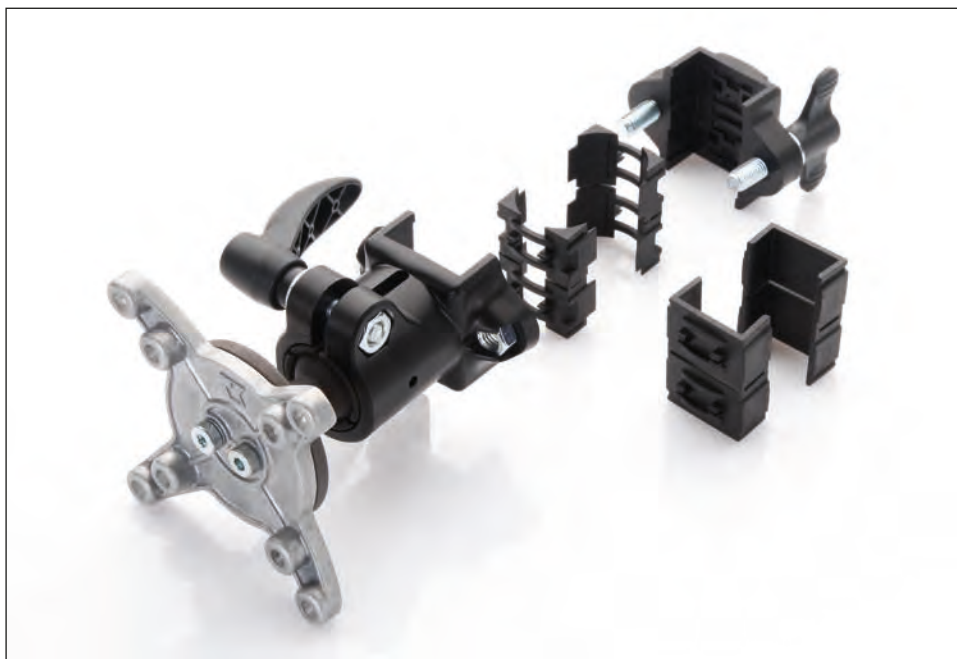

RK Monitor Mounting

Versions



Console monitor mounting



Locking in 15° - steps

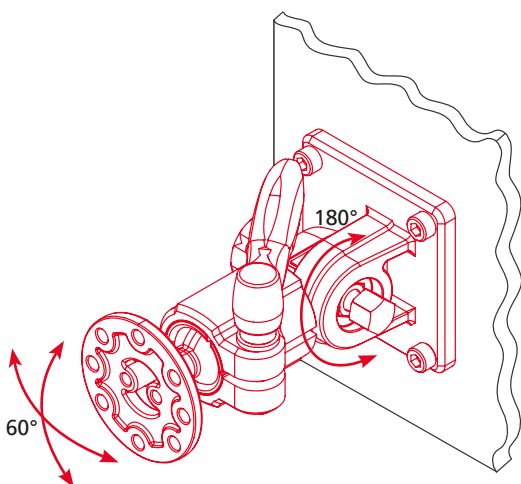
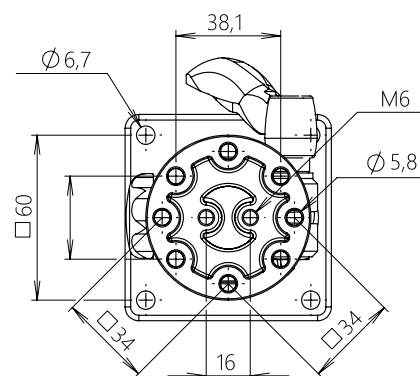
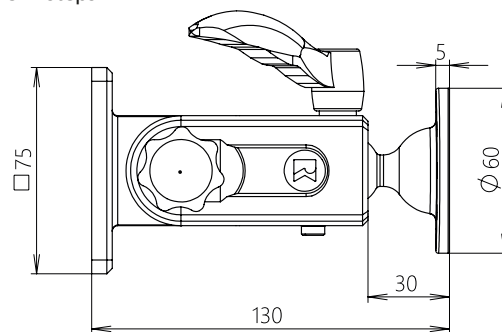

Code No.	Weight	max. load	
		dynamic	static
193000378C19	284 g	3 kg	10 kg



Dual-ball monitor mounting

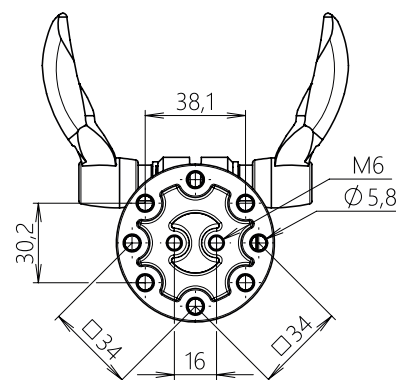
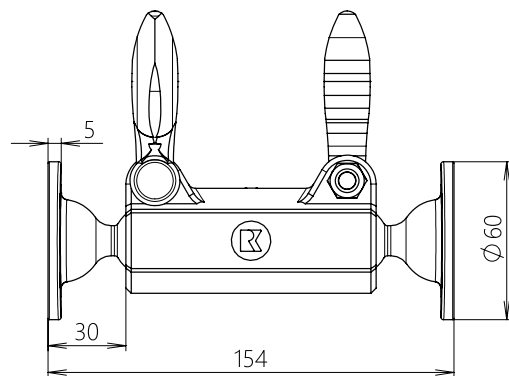
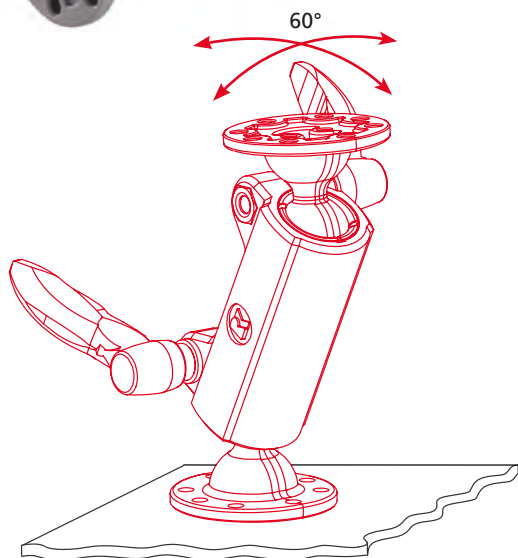

Code No.	Weight	max. load	
		dynamic	static
193000368C19	310 g	3 kg	10 kg

Dual-ball pivoting monitor mounting

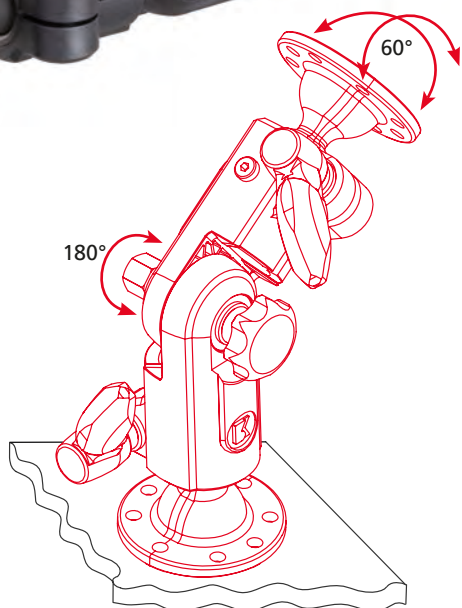

Locking in 15° - steps

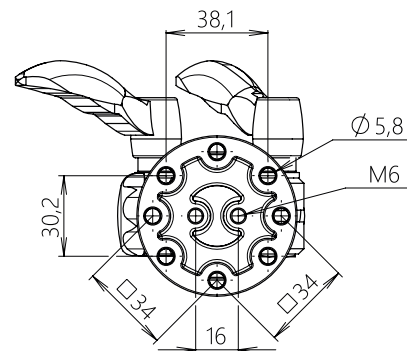
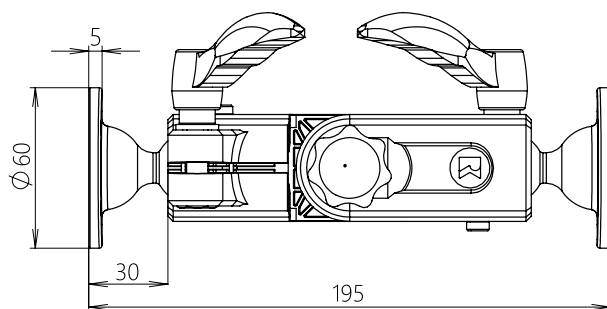

Code No.	Weight	max. load	
		dynamic	static
193000388C19	391 g	3 kg	10 kg

RK Monitor Mounting

Fixing

Wall console

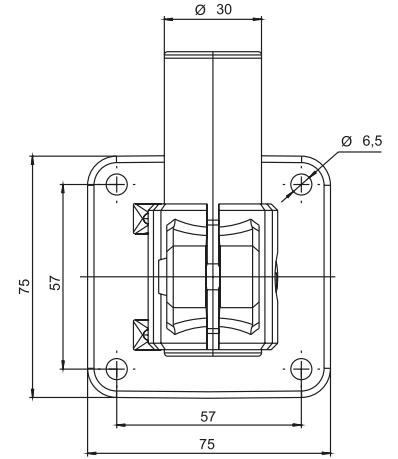
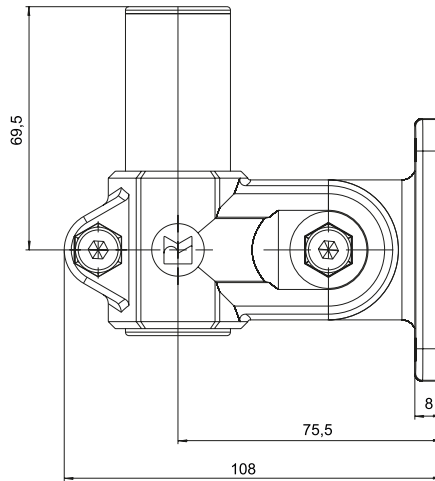
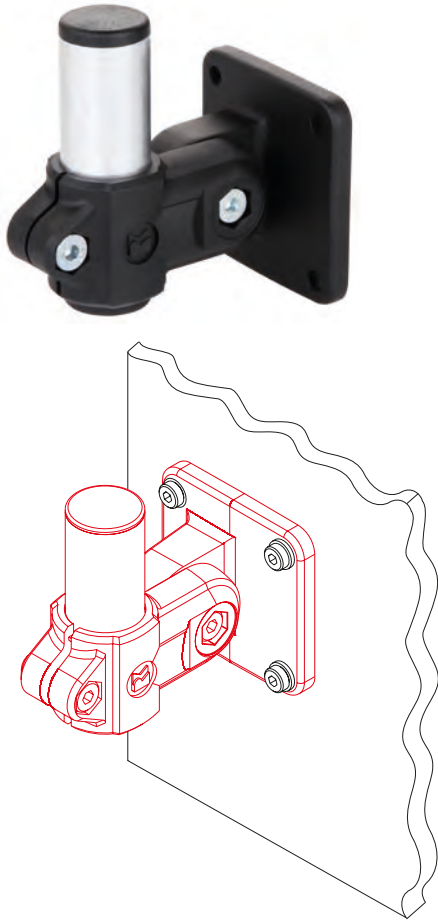

Code No.	Weight
193000358C66	306 g

Profile console

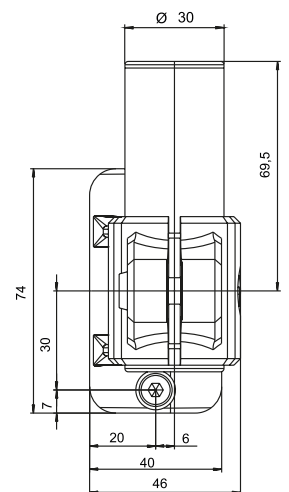
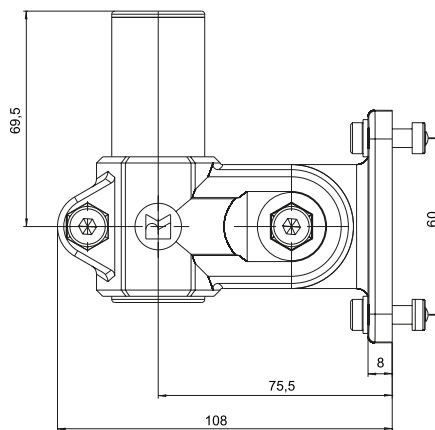
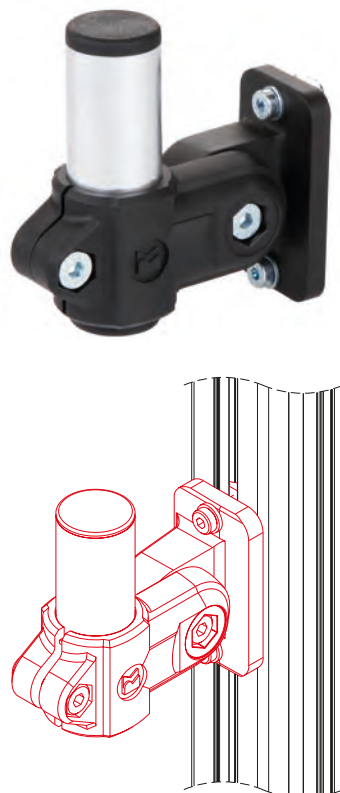

Includes:
Complete with fixing set for slot geometry 40

Code No.	Weight
193000298C66	270 g



Support arm single

Includes:
Complete with fixing set for slot geometry 40

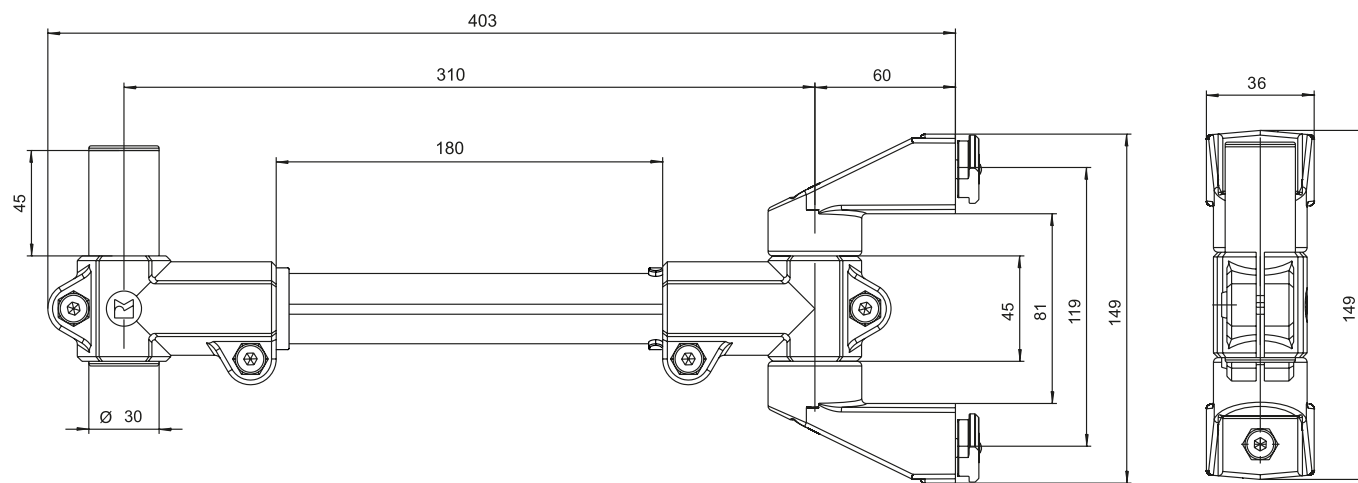
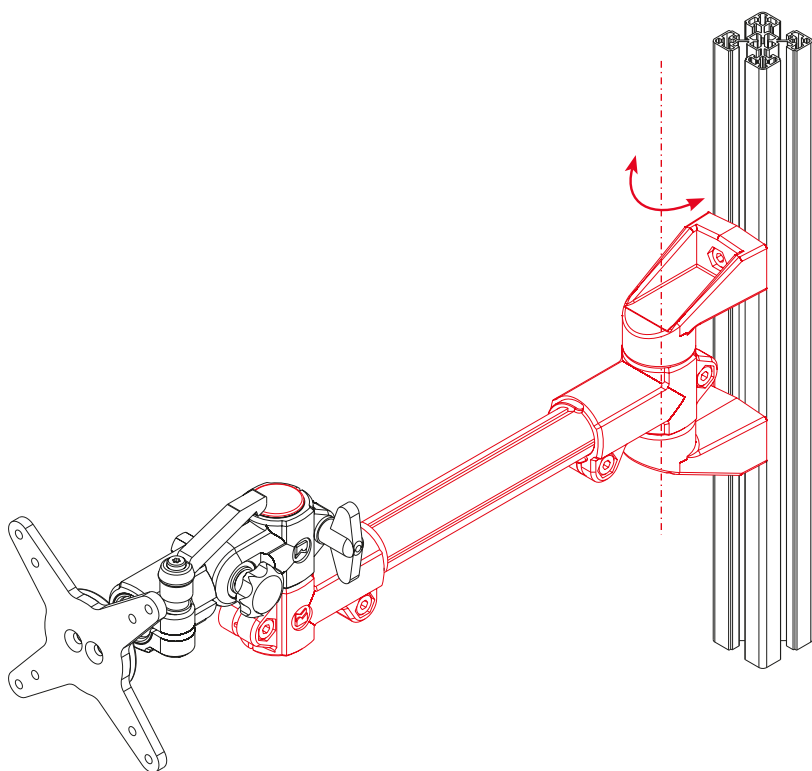

Code No.	Weight	max. load
193000018C66	610 g	10 kg

RK Monitor Mounting

Fixing

Support arm double

Includes:

Complete with fixing set for slot geometry 40

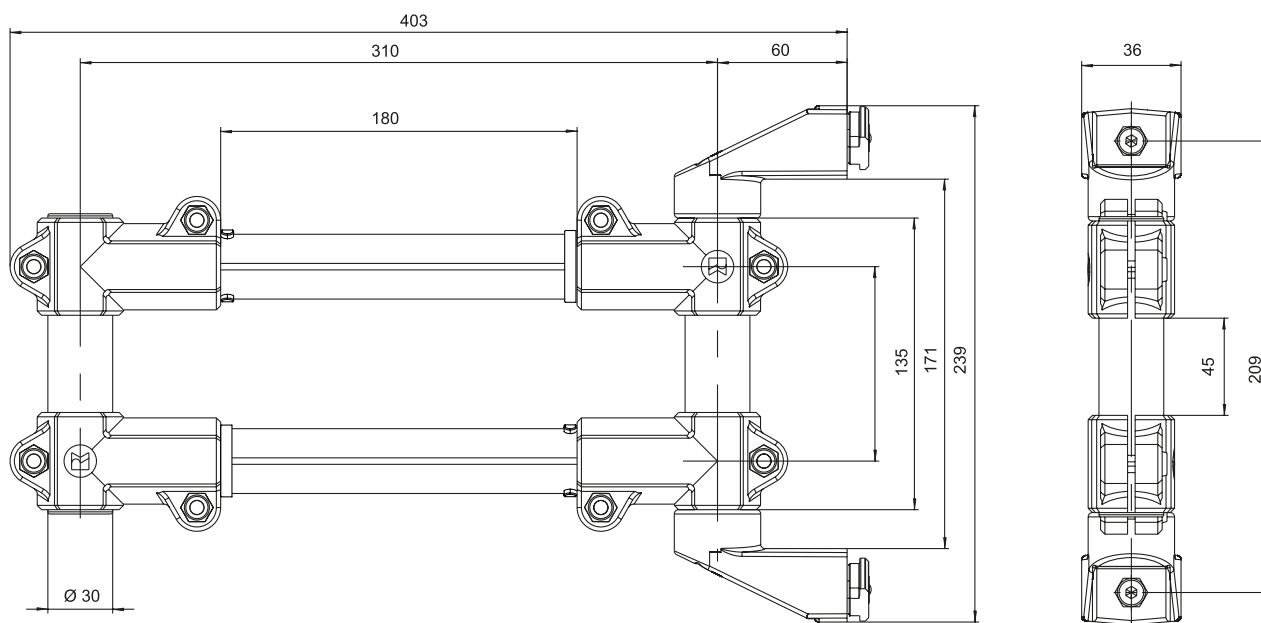
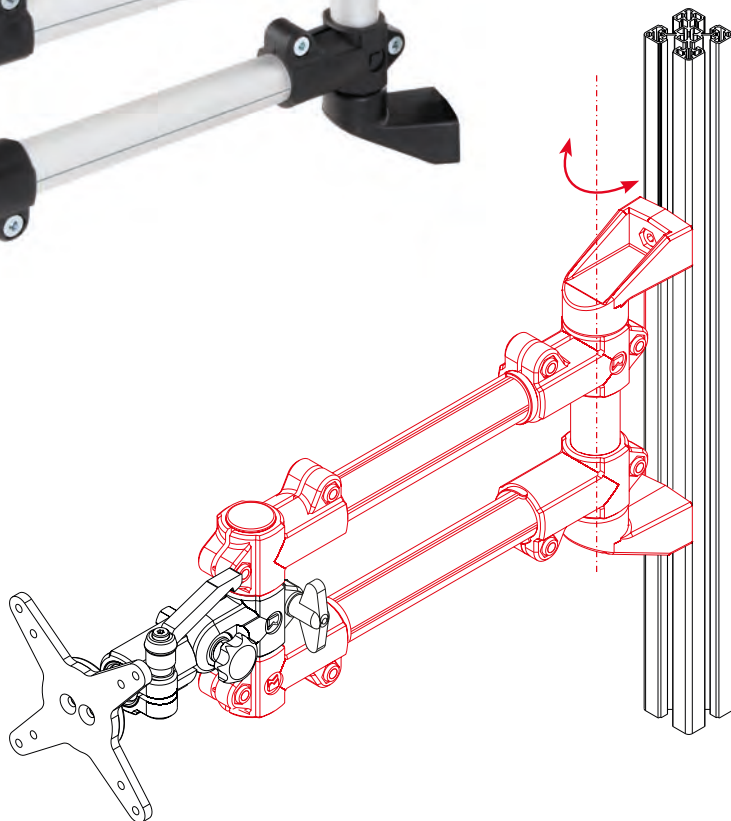

Code No.	Weight	max. load
193000028C66	1030 g	25 kg



RK ROSE+KRIEGER

Support arm double height adjustable



Includes:

Complete with fixing set for slot geometry 40

- Features:
- Travel 400mm max. (30 mm steps)
- Toolless manual adjustment
- Safe locking by a spring-loaded stop bolt

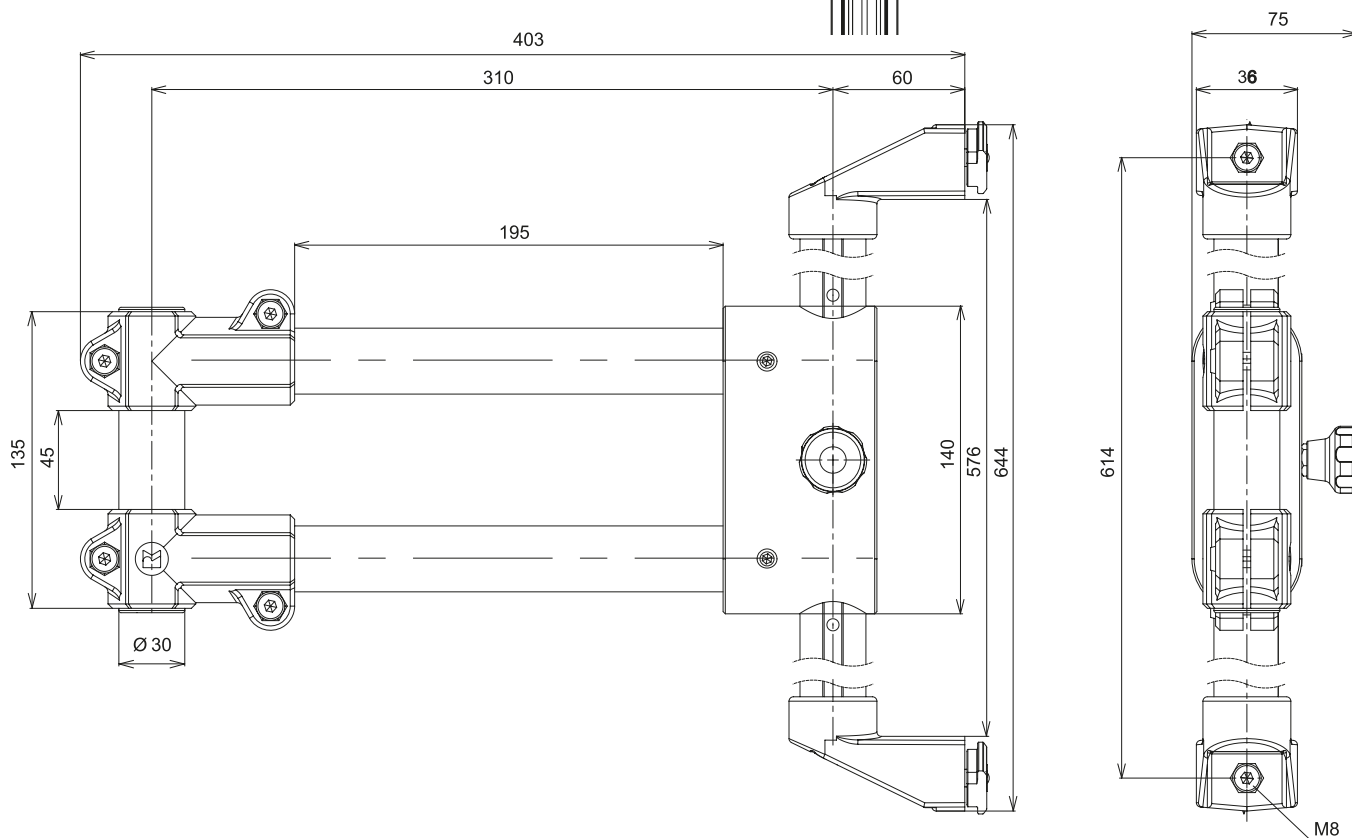
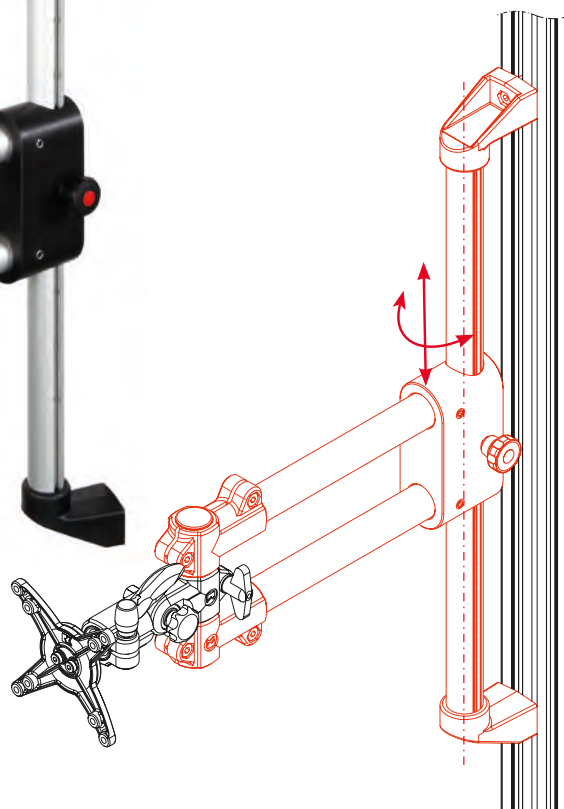

Code No.	Weight	max. load
193000068C66	2040 g	10 kg

RK Monitor Mounting

Fixing

Support arm telescope

Includes:

Complete with fixing set for slot geometry 40

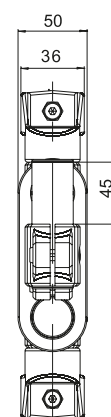
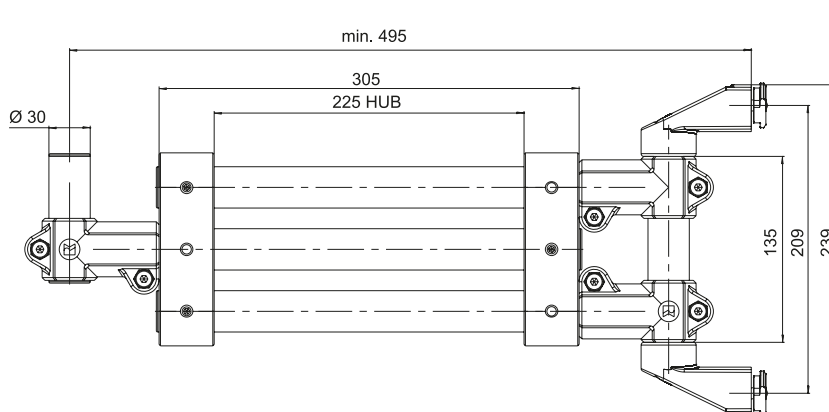
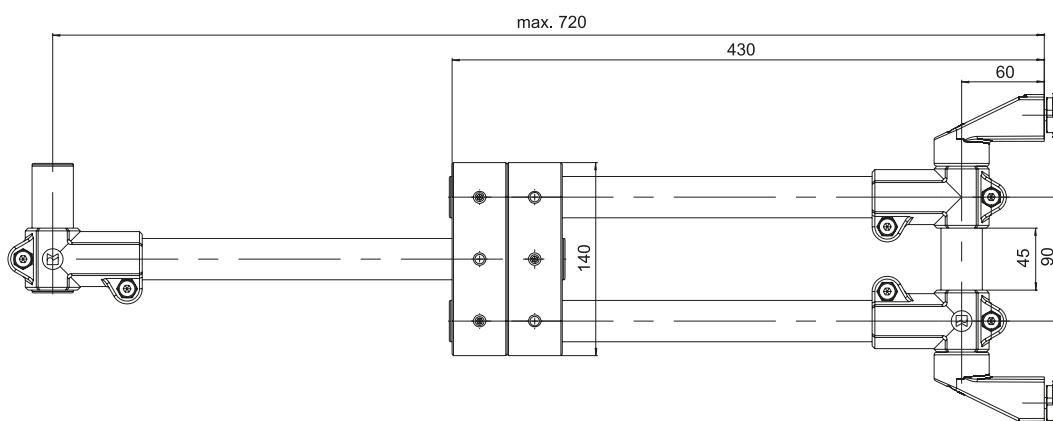

Code No.	Weight	max. load
193000048C66	1610 g	5 kg

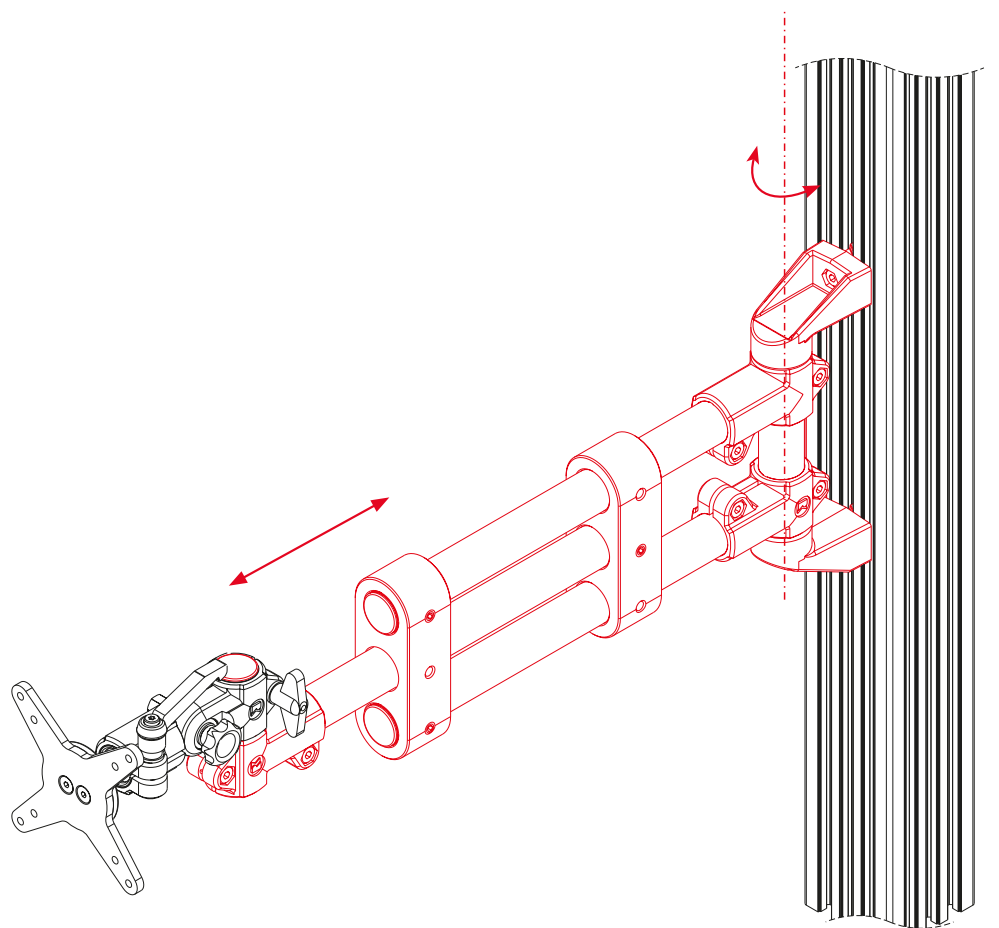
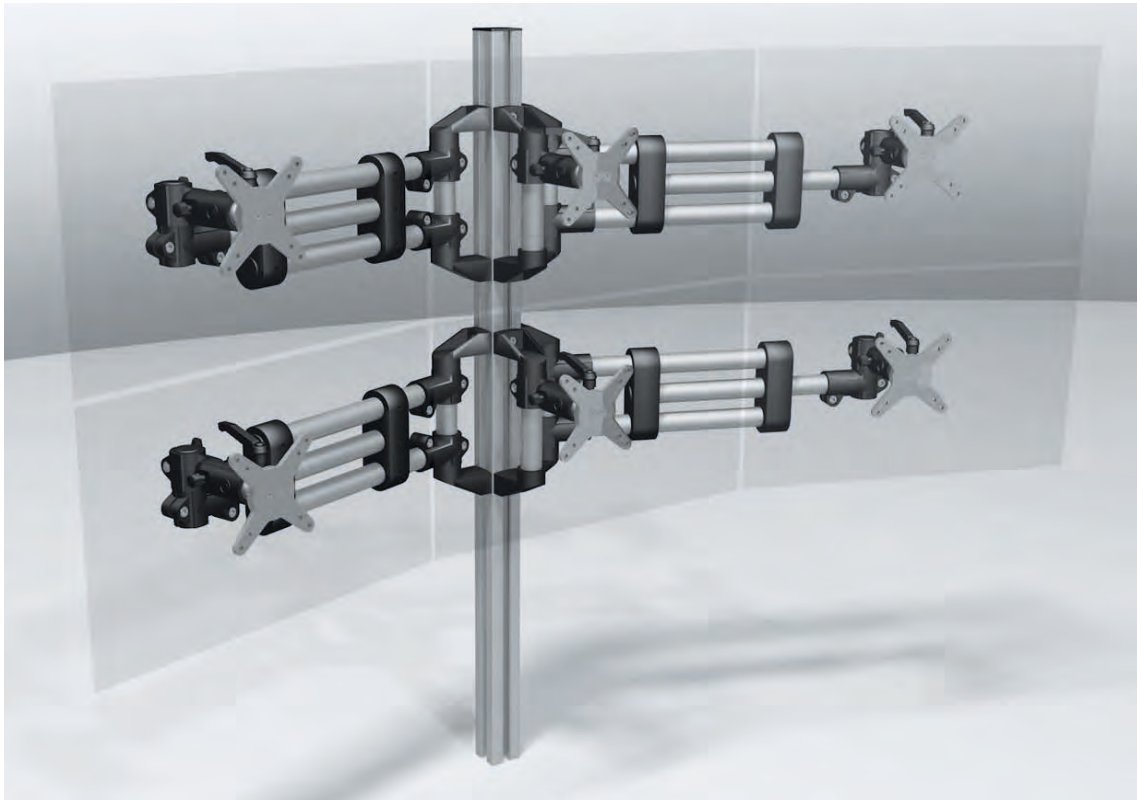

RK Monitor Mounting

Fixing

Support arm telescope
height adjustable



Includes:
Complete with fixing set for
slot geometry 40

Features:

- Travel 400mm max. (30 mm steps)
- Toolless manual adjustment
- Safe locking by a spring-loaded stop bolt

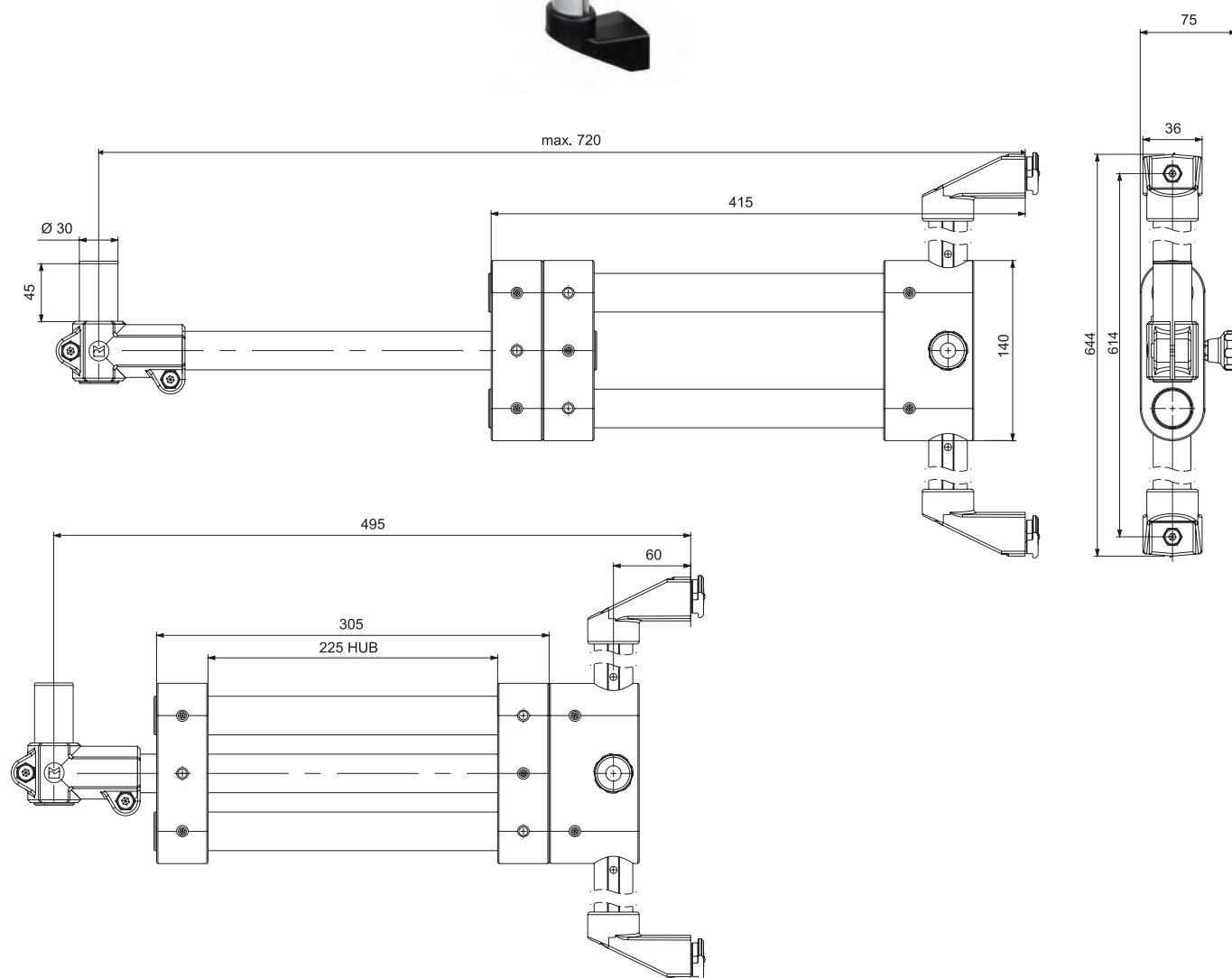

Code No.	Weight	max. load
193000058C66	2640 g	5 kg

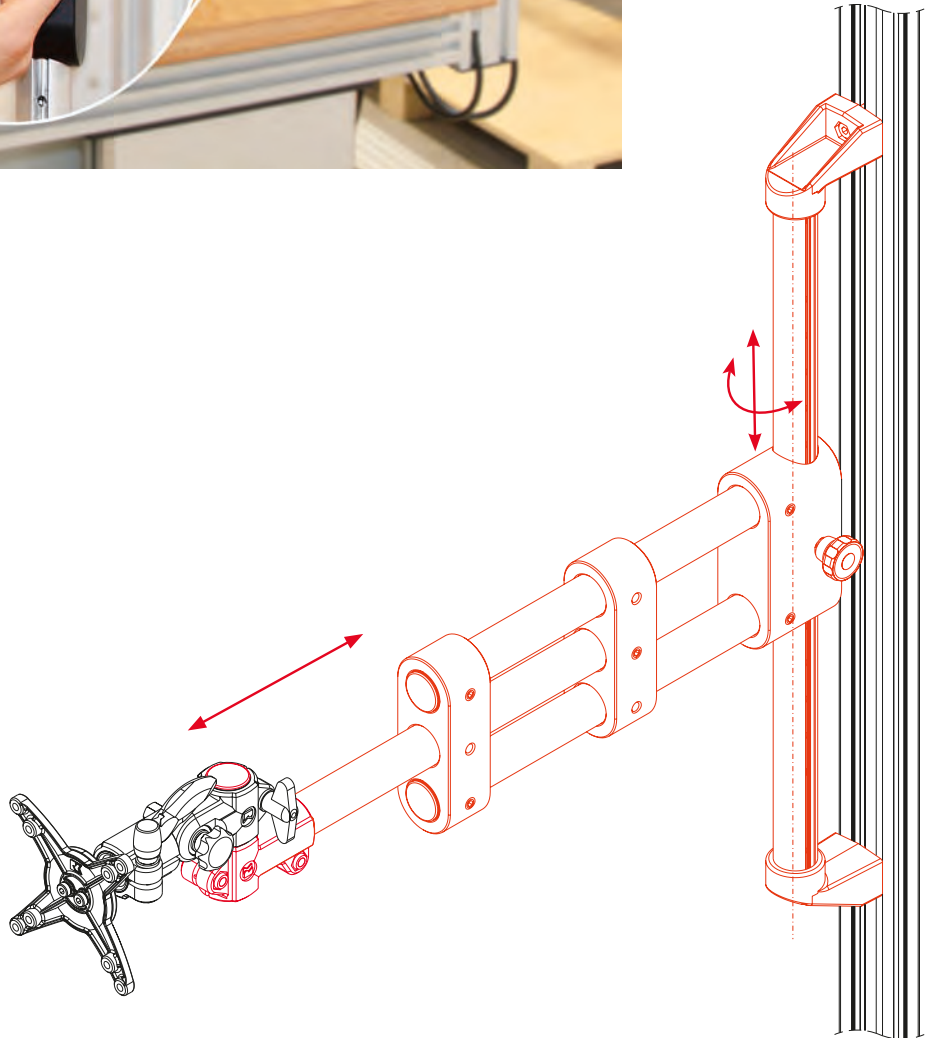

Modules

Monitor floor stand adjustable

Includes:
pre-assembled kit

Features:

- Adjustable 400 mm max. (31 mm steps)
- Tool free height adjustment
- Safe locking of the height adjustment by spring-loaded locking bolt
- Stable construction with adjustable feet, optional with swivel castors (Accessories page 311)
- Coated working surface (0.30m²)
- Integrated cable channel
- Monitor mounting included
- Combinable with other RK monitor mountings



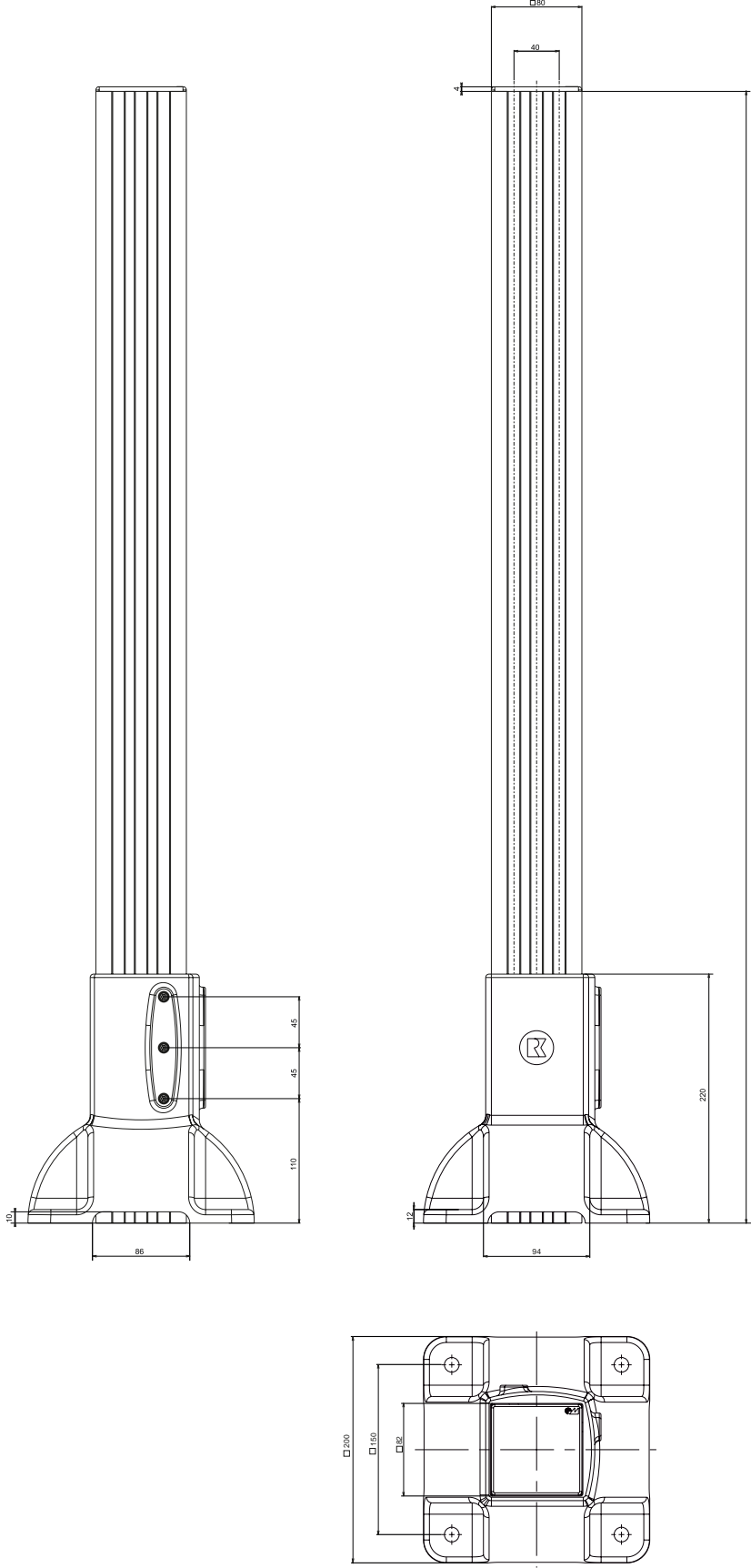

Code No.	Weight
193000078C66	22.2 kg

RK Monitor Mounting

Modules

Monitor floor stand
adjustable

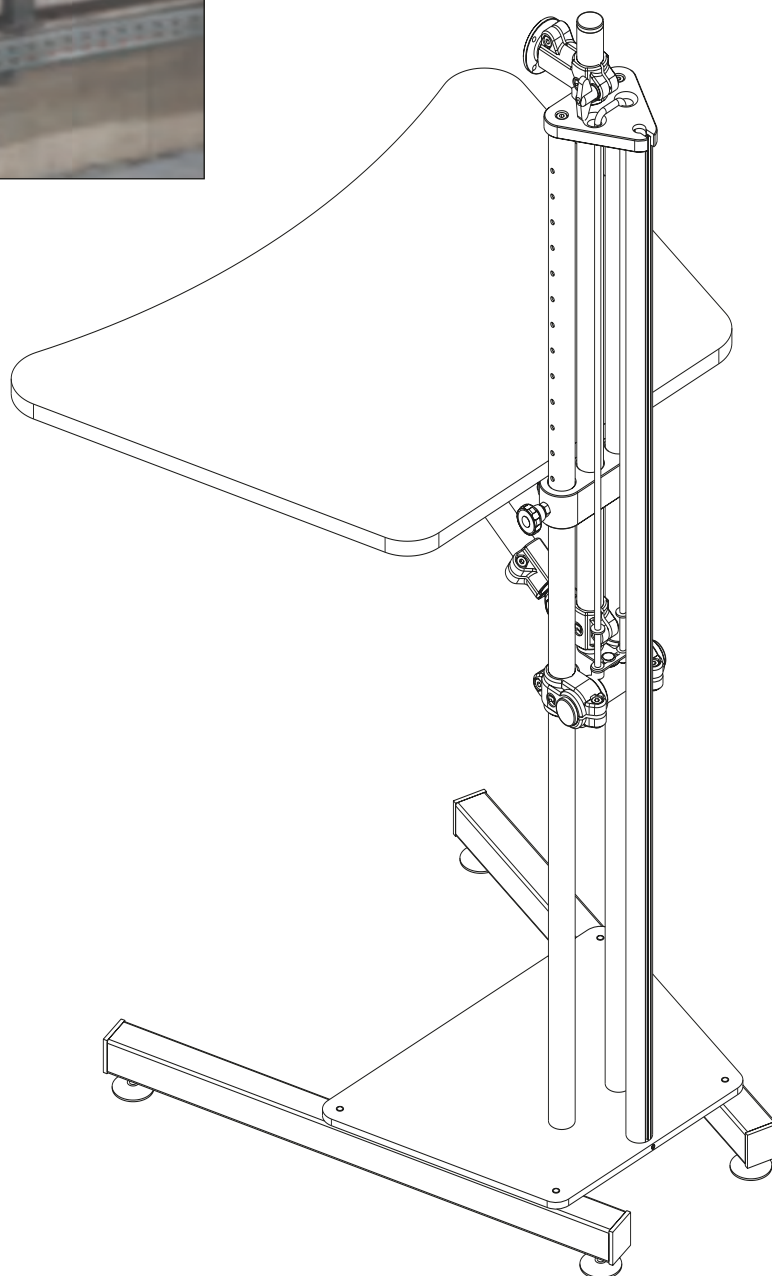



Height adjustment for monitors



Cable guide



Height adjustment table top (locking bolt)



Optional: Lockable swivel castor (p. 277)



Tie rod

RK Monitor Mounting

Modules

Monitor floor stand stationary

Features:

- Central column made of high-grade BLOCAN® aluminium profile
- Profile slots (10 mm) make it easy to fasten a range of different modules
- Individual equipping with RK modules e.g. coated table top (0.30 m²), various mounts for monitors, keyboard shelf (height-adjustable), integrated cable channel
- Sturdy aluminium base for stability and durability

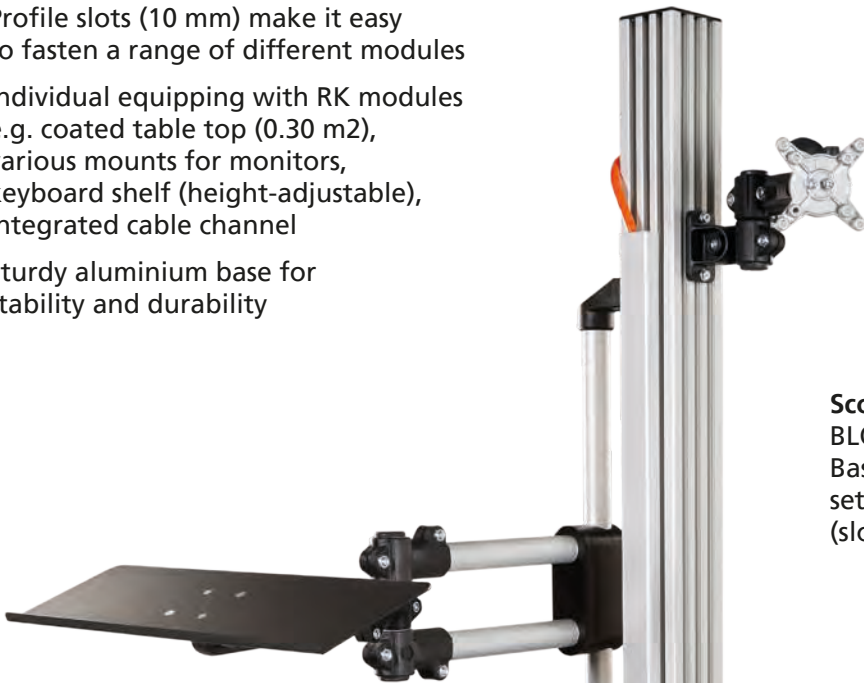

Scope of delivery:
BLOCAN® aluminium profile 80x80 mm
Base bracket BAK 80,
set screws M8x25 for fastening
(slot profile in base bracket)





Monitor floor stand stationary with base bracket

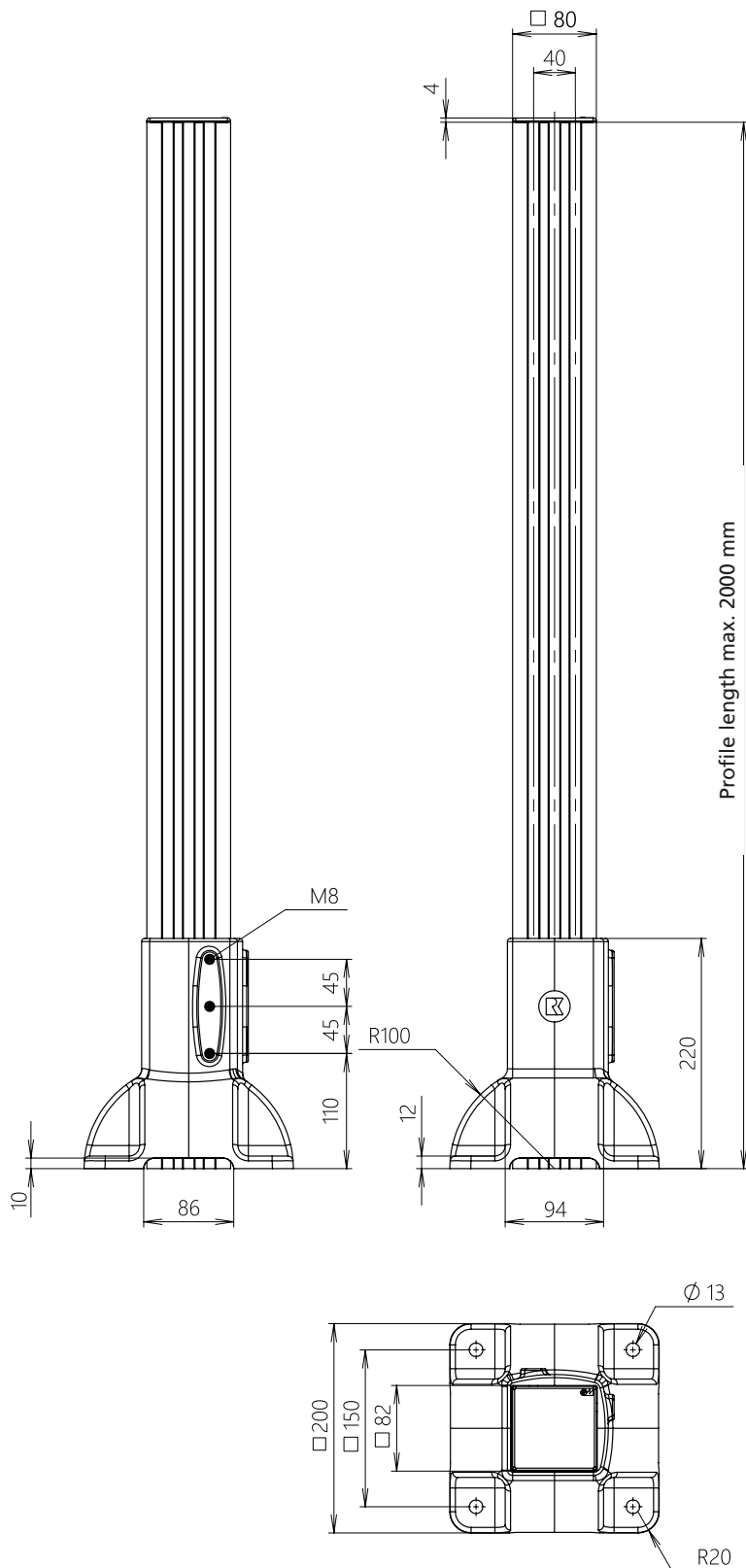

High performance anchor
Drilling diameter 12 mm,
length 110 mm



Code No.	Type	Weight
193000398C66__	monitor floor stand stationary	8,791

Code No.	Type	lot sizes
4016611	HLA	4, 8, 12... pcs.

RK Monitor Mounting

Modules

Monitor floor stand stationary





Monitor Mounting

- Secure mounting for monitor or display device
- Swivelling, rotatable and height-adjustable

Support arm/swivel arm

- Ideal for flexible positioning
- Double, telescoping, height-adjustable (see page 14)

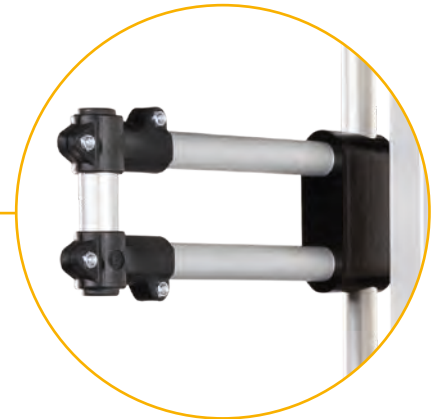

Keyboard tray
(see page 29)

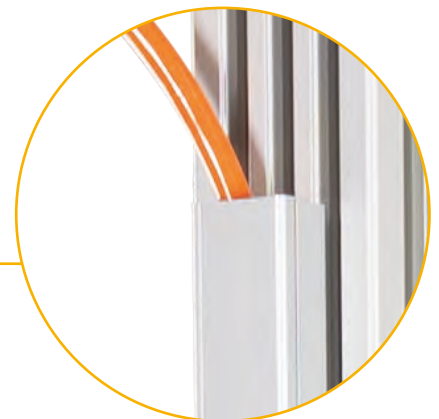

Cable channel

- Simple and safe routing of supply lines (see page)

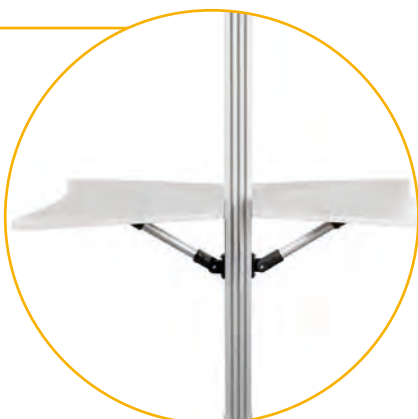

Table Top

- Work surface for writing or depositing objects (see page 24)

RK Monitor Mounting

Accessories Monitor floor stand stationary

Table top

Scope of delivery: Including fixing kit

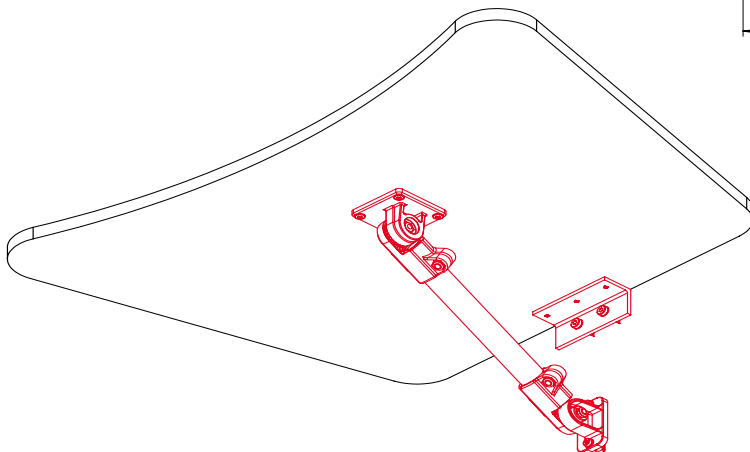
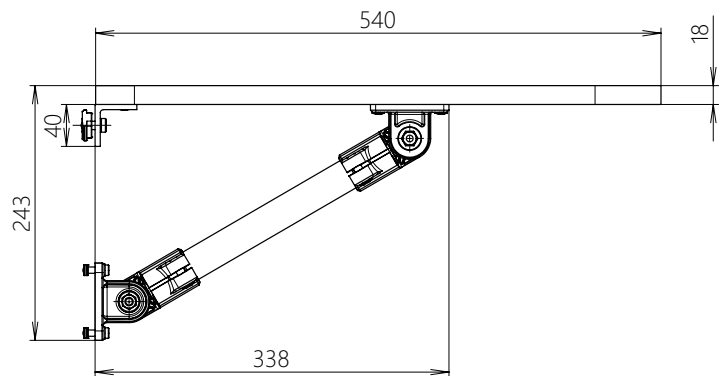
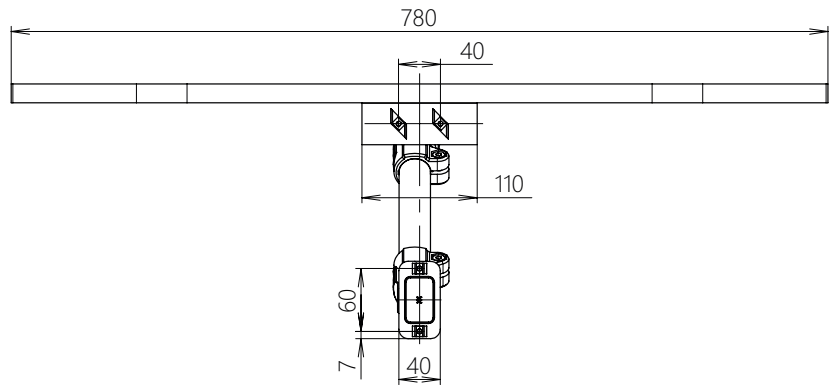

Code No.	Type	Weight	max. load
193000408C66	table top stationary	4,48 kg	20 kg



Cable channel

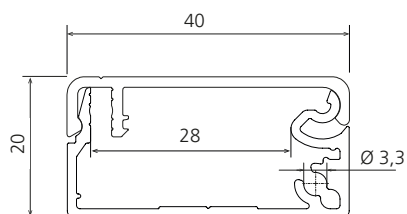
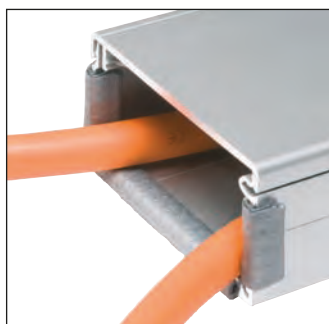

Code No.	Profile	Type	Weight
4F55A00	KK-40x20, Cut to size as required	Channel with fixing holes	0,609 kg/m

Cable mounting clip

Material: PA-GF30

Assembling the channel

Easy assembly (no profile drilling) with BLOCAN profiles.

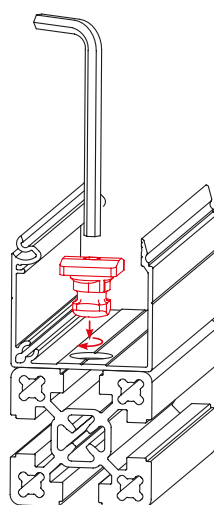

as required Ø12 pre-punched (approx. every 200 mm)

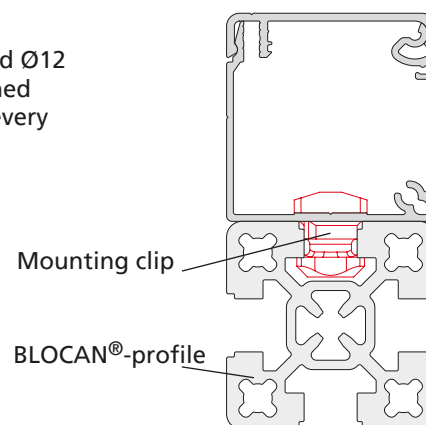

Code No.	for KK-Profile	lot sizes
4E185031	all	10, 20, 30... pcs.

Accessories Monitor floor stand stationary

Order instruction:

- Purchase only in lot sizes and a multiple of that, see product table below

Caps (plastic) for aluminium profile column

- For closing the aluminium profile column



 Black RAL 9005*

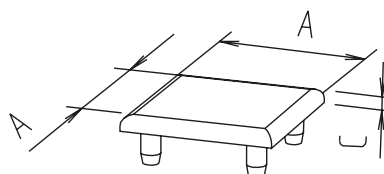

[mm]

Code No.	Type	A	C	lot sizes
4040421	80x80	80	4	10, 20, 30... pcs.

*More colours, see catalogue „Profile Technology BLOCAN[®], page 98

Cover profile for aluminium profile column

- For flush covering the longitudinal grooves in the aluminium profile column

Material: plastic



 Black RAL 9005*

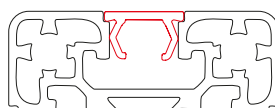

Code No.	Type	Colour
4000570	2 m-bar	Schwarz

*More colours, see catalogue „Profile Technology BLOCAN[®], page 101

Application



RK Monitor Mounting

Accessories

Adaptor plate VESA 50/75

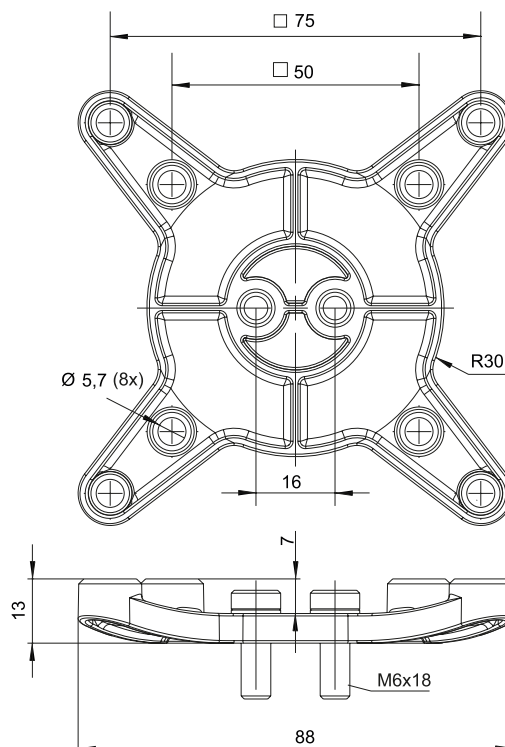
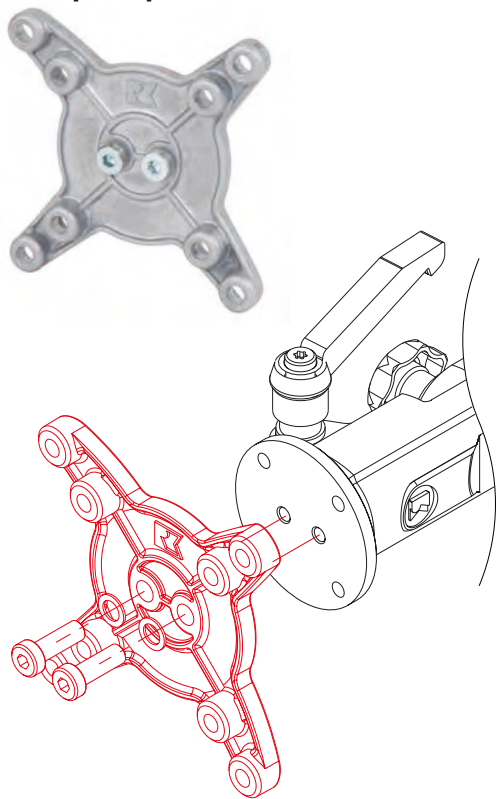

Code No.	Weight
94372	67 g

Adaptor plate VESA 75/100

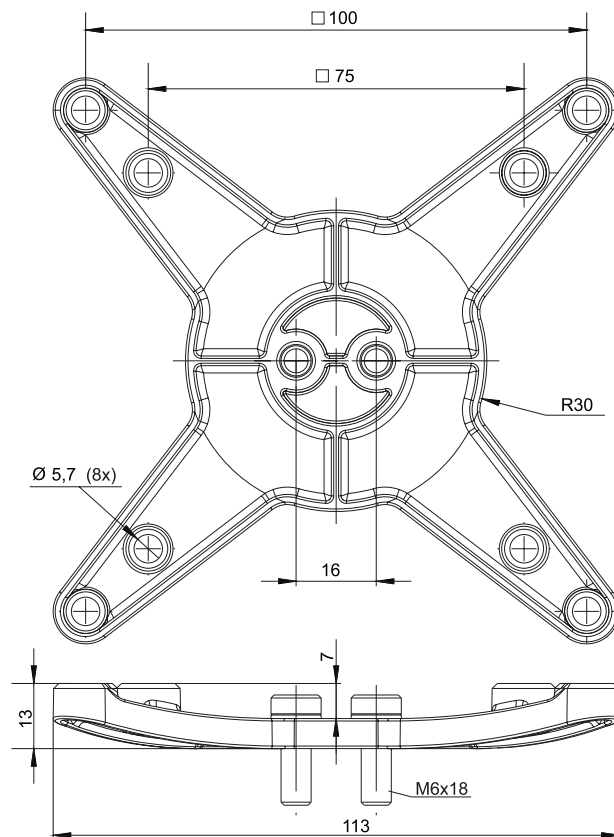
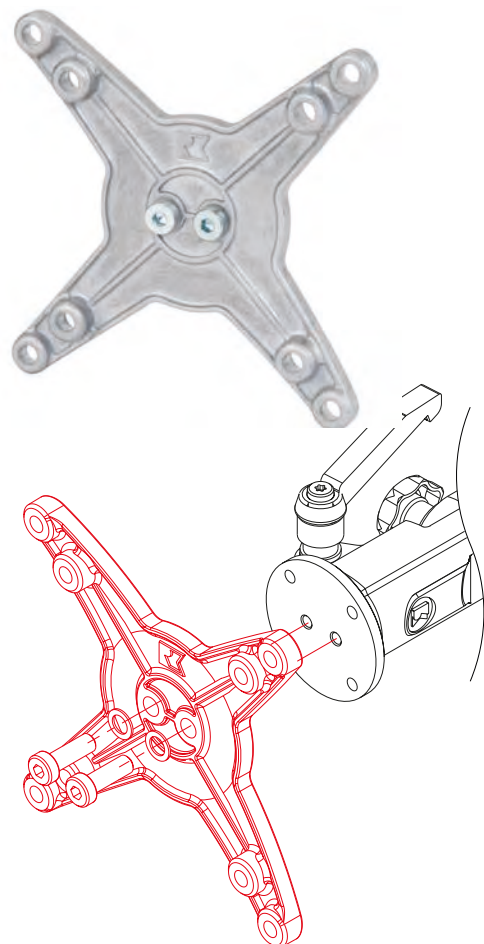

Code No.	Weight
94371	80 g



Keyboard tray

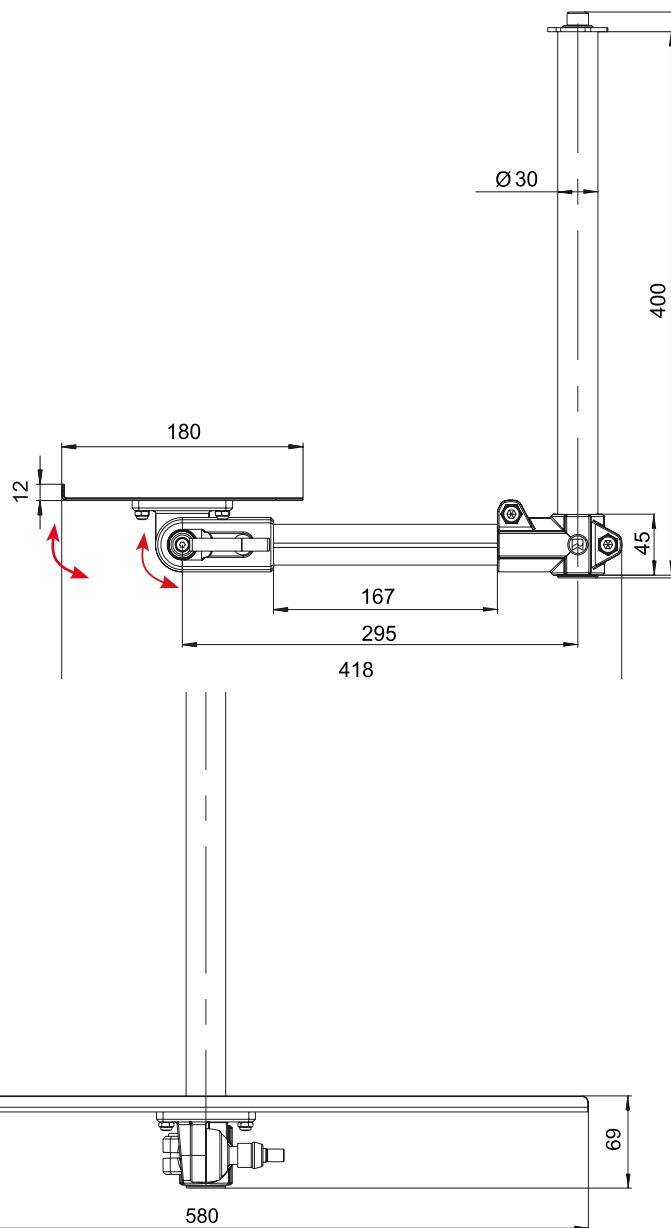
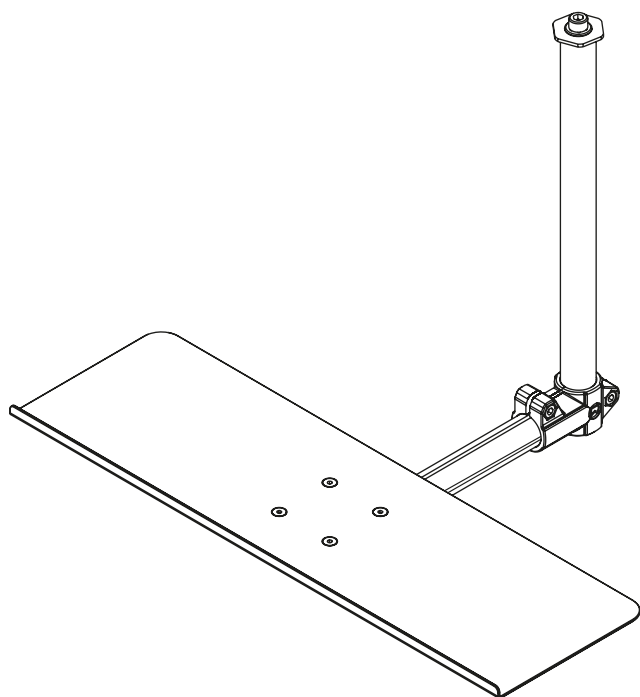

Designed for Support arm double

Code No.	Weight
193000038C66	2500 g

- Introduction
- Selection guide
- Light Clamps
- Solid Clamps
- Robust Clamps
- EMS
- Accessories
- ITAS
- RK Monitor Mounting**
- Appendix

RK Monitor Mounting

Accessories

Notebook holder

Material:

Black powder-coated sheet steel,
Clamping plastic

Includes: fixing set to connection
plate VESA 75/100

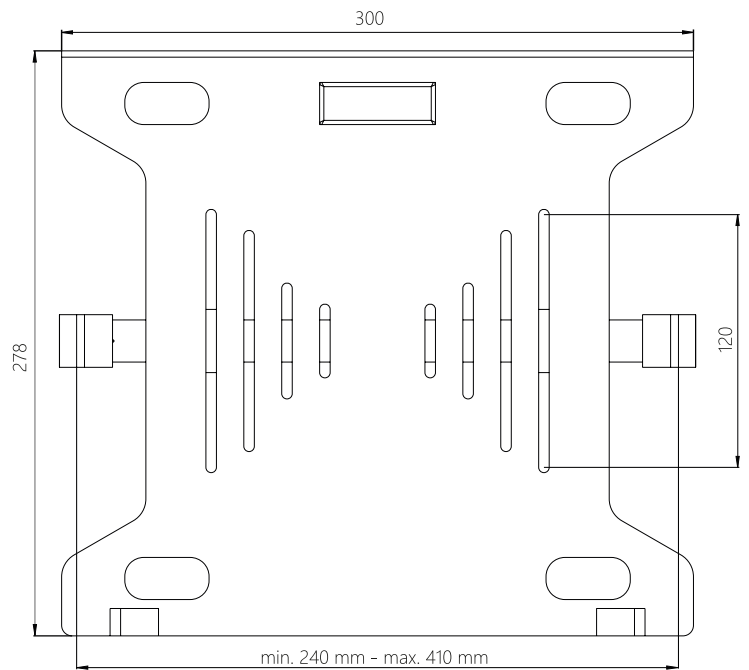
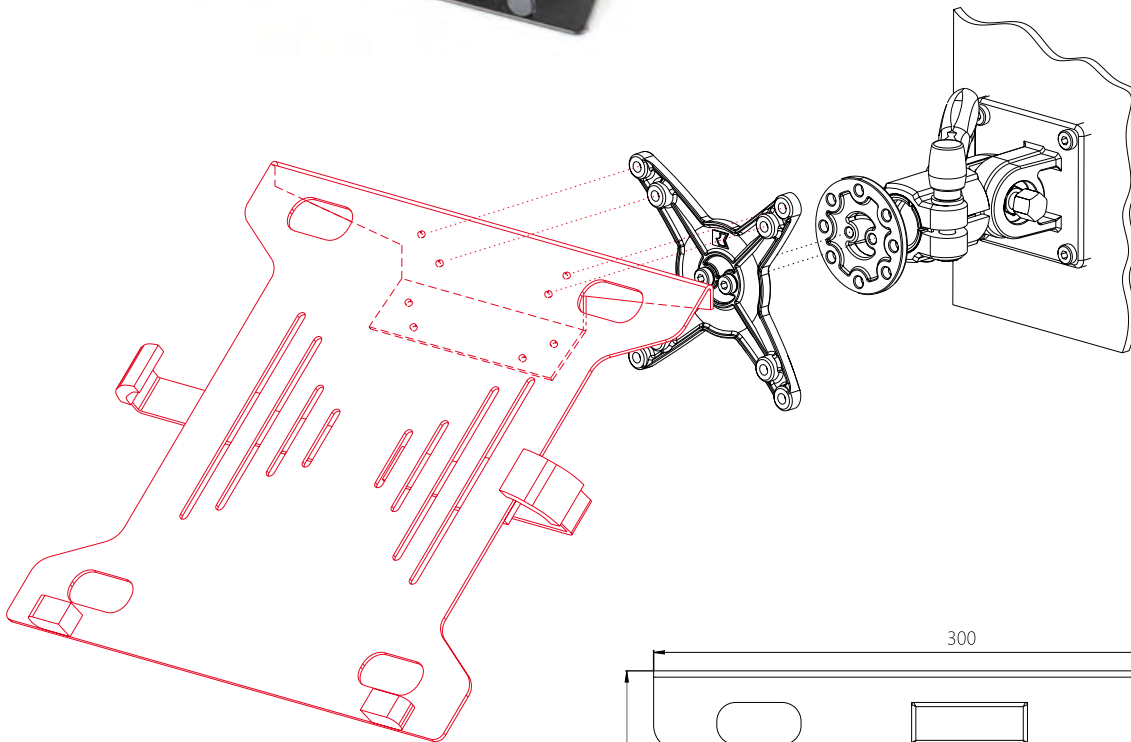

Code No.	Weight
94373	1211 g



Tablet holder

Includes: fixing set for RK monitor mounting

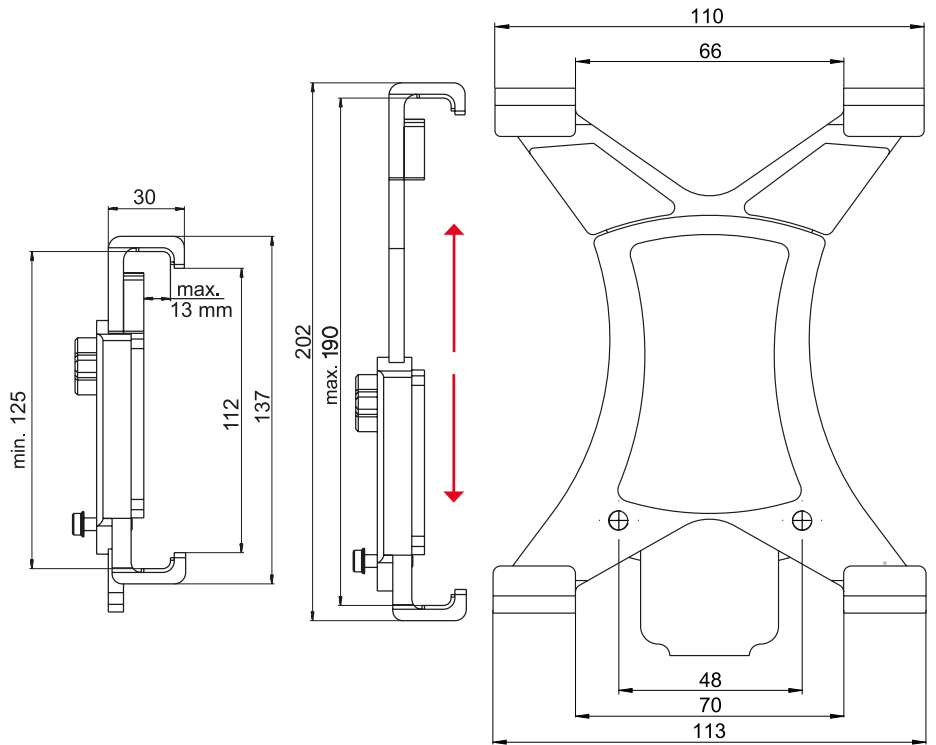
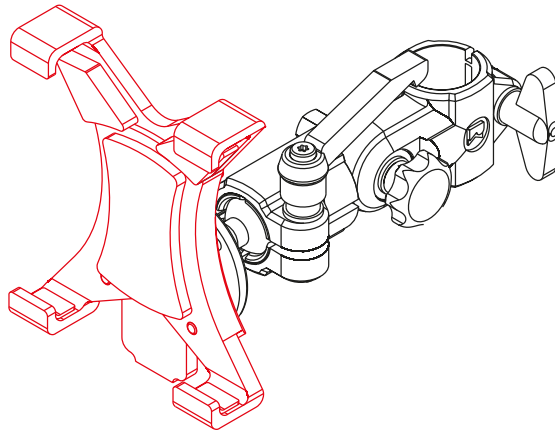
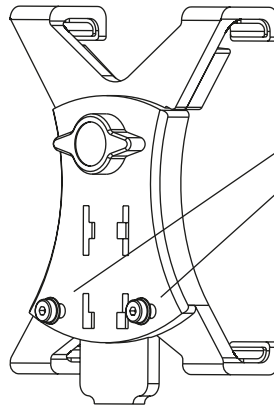

Code No.	adjustment range
193000052C66	125 mm - 190 mm

RK Monitor Mounting

Applications

Smartphone holder

Delivery includes:

including fastening 30 mm round tube and fastening to RK Rose+Krieger Profile system (40 mm groove geometry)

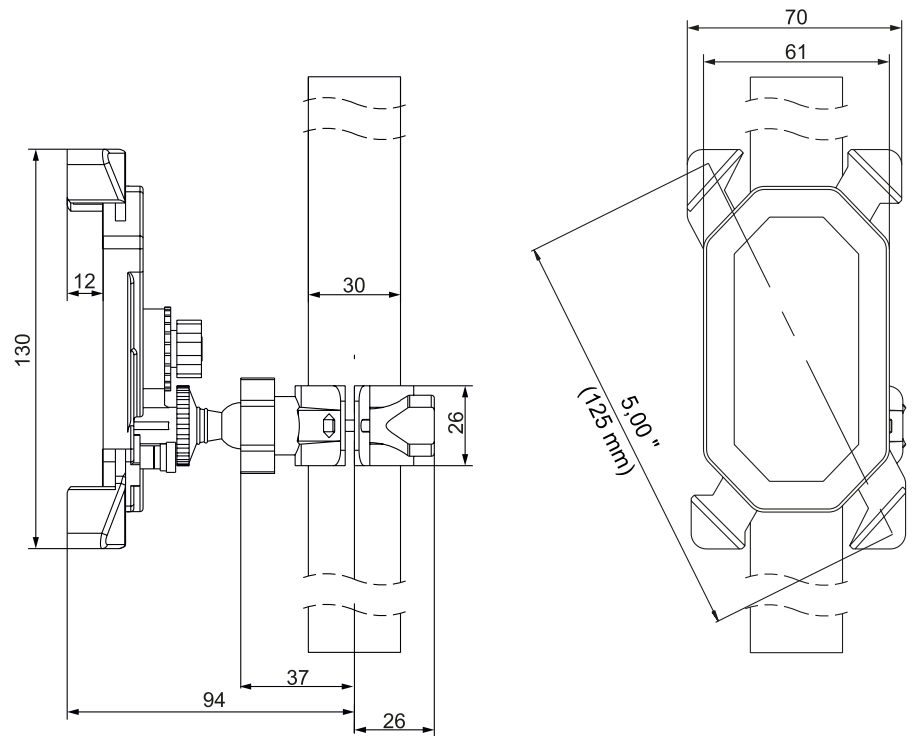
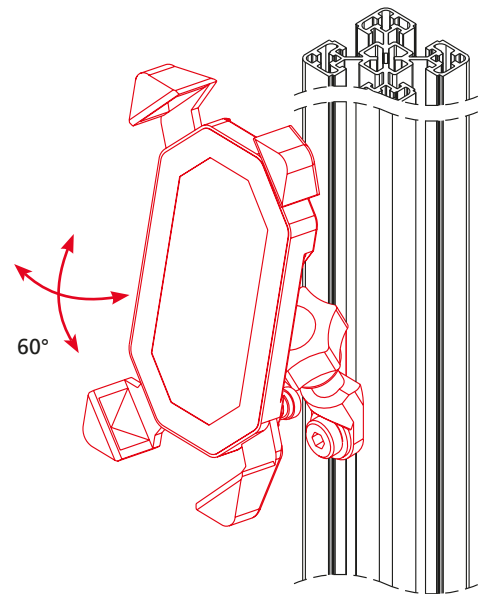
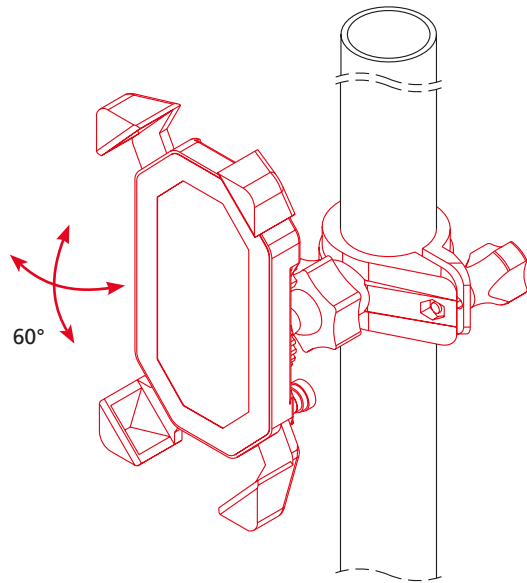

Code No.	adjustment range
193000038C69	from 125 (5 inch) to 185 (7.25 inch) mm



Lockable swivel castor

Material: galvanized steel
Includes: fixing set

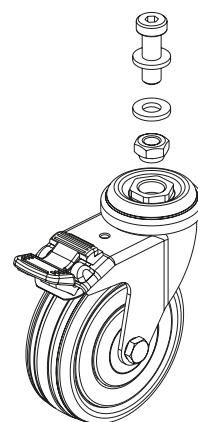
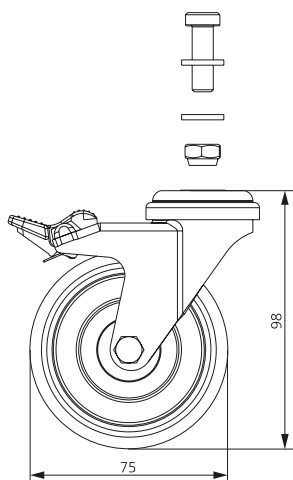

Code No.	Weight
90503	34 g

Order instruction:

- Purchase only in lot sizes and a multiple of that, see product table below

Vario-Quick holding block K/KK

Version K

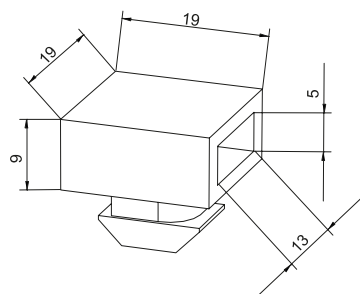

Version KK

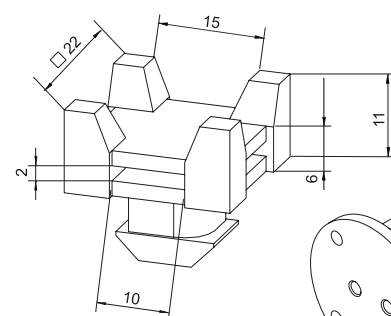

- For fixing cables and hoses
- It is possible to insert it into the profile slot retrospectively

Material: Black plastic

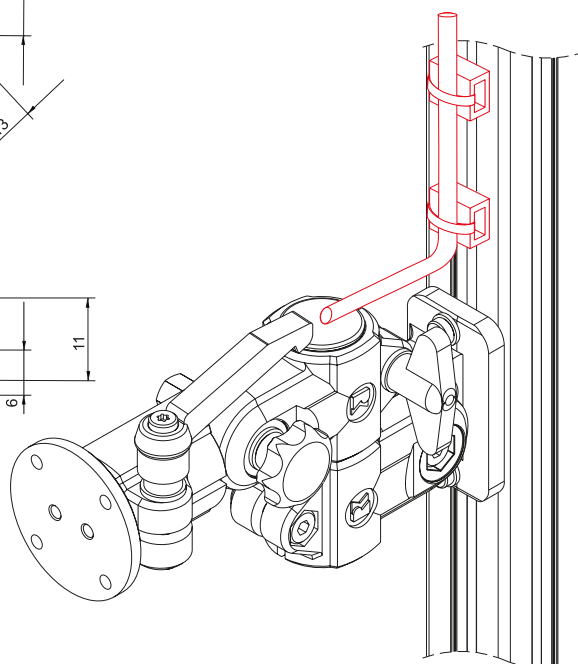

Code No.	Version	lot sizes	Suitable for
40181251	Holding block K	10, 20, 30... pcs	40 slot geometry*
40181271	Holding block KK	10, 20, 30... pcs	40 slot geometry*

* Slot geometry RK Profile Technology

Applications

Order instruction:

- Purchase only in lot sizes and a multiple of that, see product table below

Reducing bushes for monitor mounting

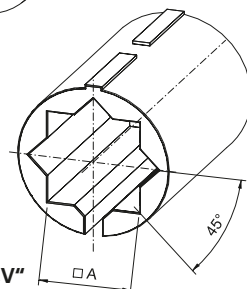
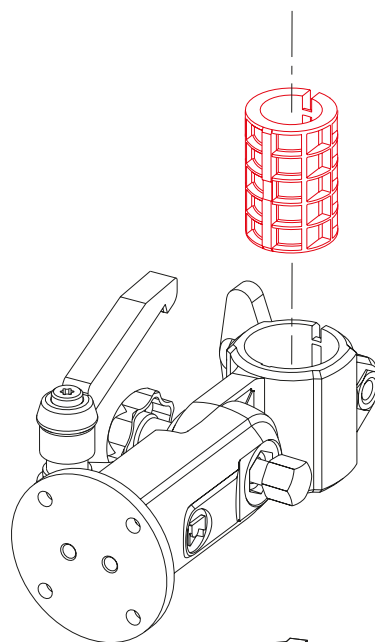
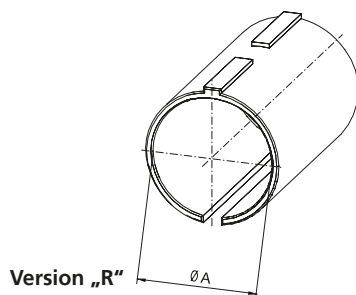

[mm]

Code No.	Version	lot sizes	A + 0,1
96204AC	R20	5, 10, 15... piece	20,25
96206AC	R25	5, 10, 15... piece	25,25
96208AC	V20	5, 10, 15... piece	20,25

Reducing inserts for monitor mounting

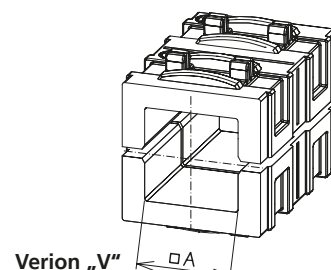
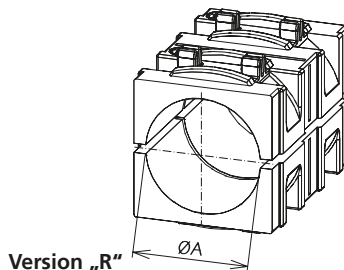

[mm]

Code No.	Version	lot sizes	A
963000AC	R20	5, 10, 15... pcs	20,25
963002AC	R25	5, 10, 15... pcs	25,25
963004AC	R30	5, 10, 15... pcs	30,25
963001AC	V20	5, 10, 15... pcs	20,50
963003AC	V25	5, 10, 15... pcs	25,50



Clamping lever

- The clamping lever enables the re- adjustment of the clamping elementp. This can be done by easy exchange of the cylinderscrew.
- By lifting the grip, the free movement of the serration toothing enables the clamping lever to swing into the desired position. The grip moves into its original position when released.

Material: Grip made of polyamide black, screws -stainless steel



(Symbolic representation)

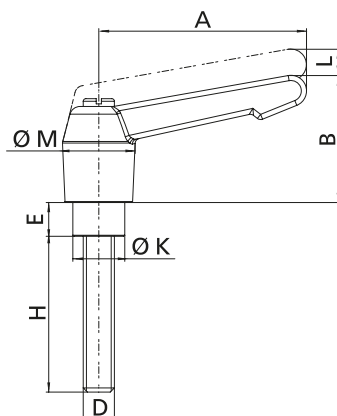

Code No.	Type	A	B	D	E	H	K	L	M
902381	20-30	65	35	M8	14	25	13	4	19,5

[mm]

Order instruction:

- Purchase only in lot sizes and a multiple of that, see product table below

Cable straps with velcro

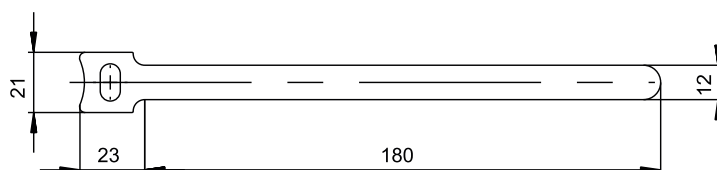

Code No.	lot sizes
91815	5, 10, 15... pcs

Appendix

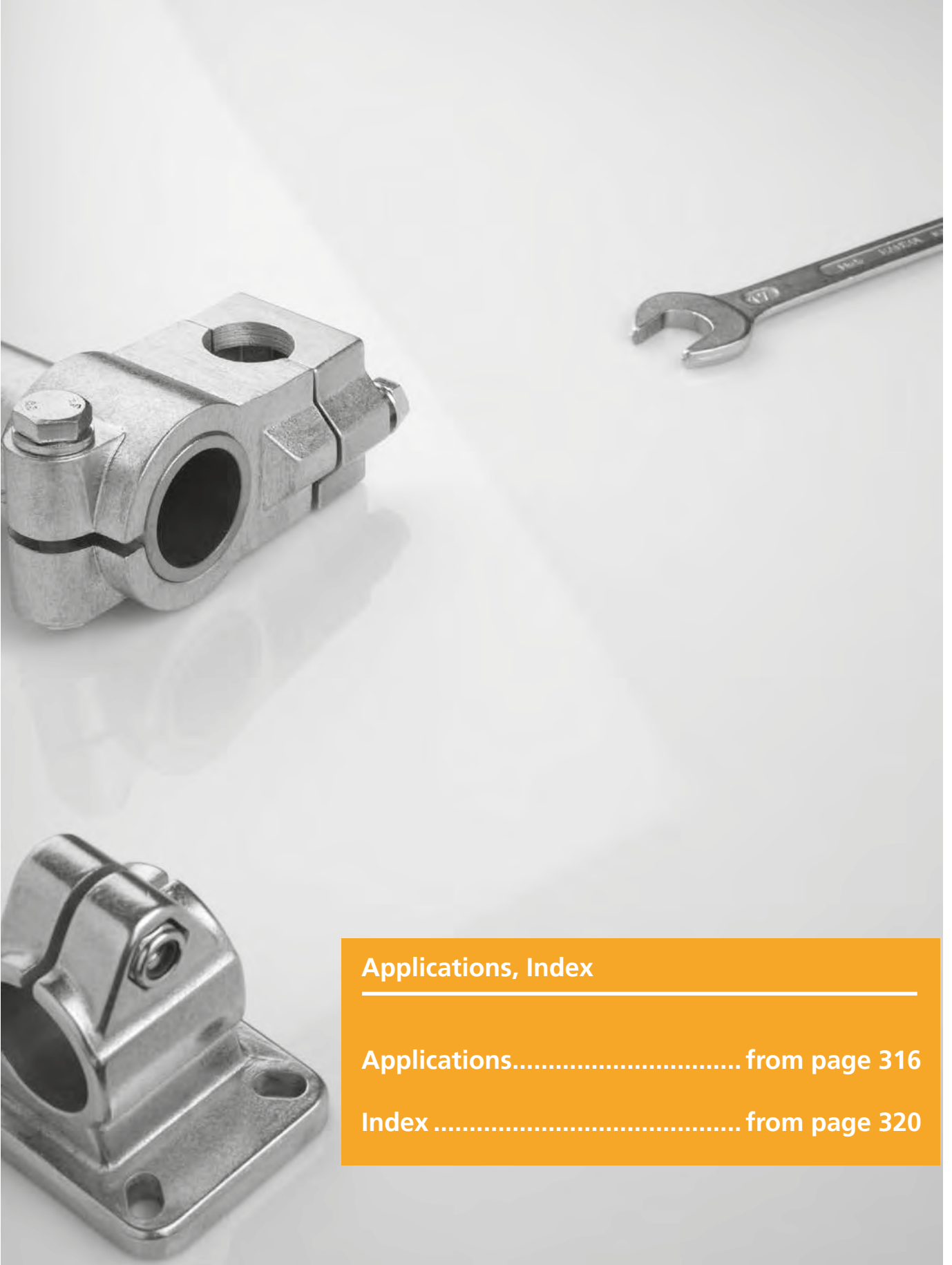

Applications, Index

Applications..... from page 316

Index from page 320

Appendix Applications



Frame for a labelling machine.



Working platform with ITAS railing

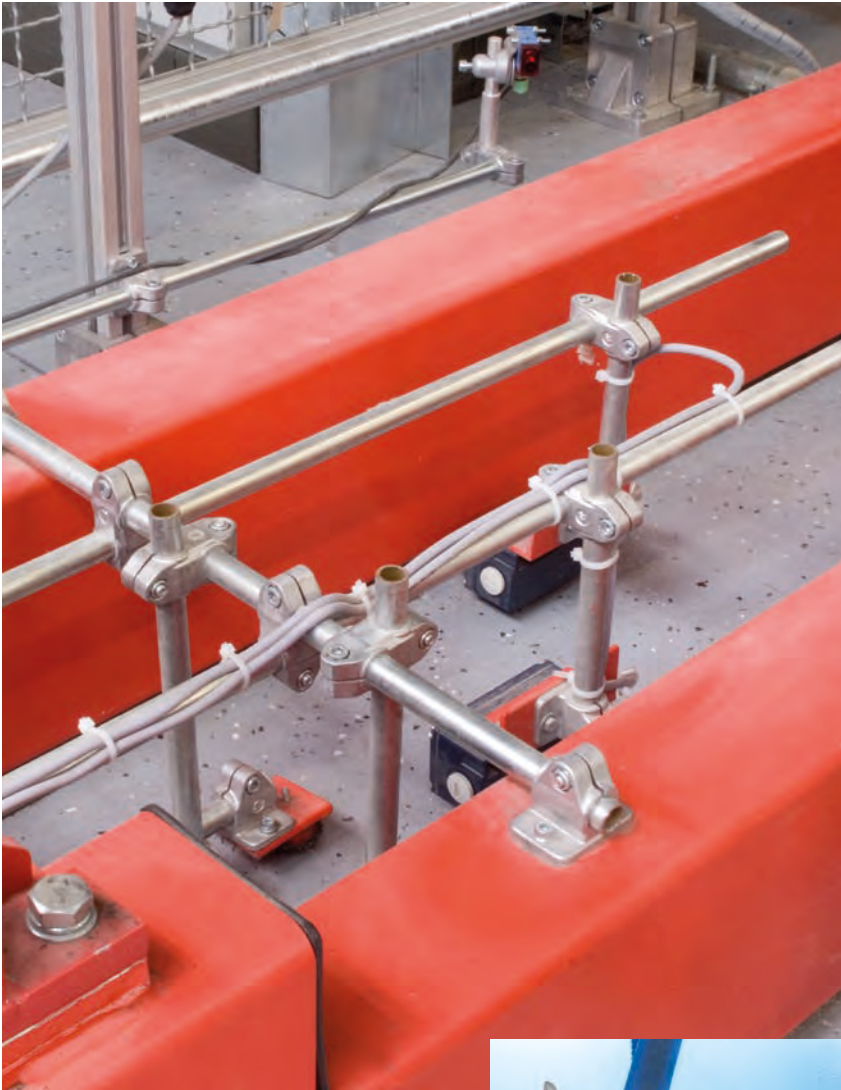

Logistic system at RK Rose+Krieger – holder for sensors.



Airbrush holder with cross clamping pcs and clamping levers.

Appendix

Applications



Testing devise



Basic frame for
pipe system of fluids or gases

Monitor mountings



Material shuttle

Index

A	
About Us	4
Accessories ITAS	256
Accessories light clamps	54
Accessories light solid robust	220-232
Adhesion force	29, 63, 79, 101, 123, 131, 141, 147, 165, 177, 211
Adjustable feet	230
Aluminium bars	225
Aluminium profile	226
Aluminium tube ITAS	257
Aluminium tubes	224
Angle clamps light	36
Angle clamps robust	215
Angle clamps solid	82-98
Angle plate	258
Anti-wist System.....	31, 52
Appendix	314
Applications	316
Axially parallel tube connector light clamps.....	32
Axially parallel tube connector robust clamp	212
Axially parallel tube connector solid clamps.....	140
B	
Ball joints.....	18 198
Base clamps light	26
Base clamps robust	216
Base clamps solid	100
Bending moment	29, 63, 79, 101, 123, 131, 141, 147, 165, 177, 211
Block form	71-74, 86-92, 112-119, 127-128, 138, 145, 153-157, 188-196
Building regulations ITAS	239
C	
CAD	6
Castors	231
Clamping lever	232
Connecting Circle	12
Connecting tube	300
Corner joint	243
Corner T-joint	243
Coupler	242
Cross clamps light	34
Cross clamps robust	214
Cross clamps solid	62-77
Cross clamps solid overview	64
D	
Dismantling of quick change system	251
E	
Enquiry form ITAS	265
EMS	218
F	
Fixed wheels	231
Flange clamps light	41-42
Flange clamps robust	217
Flange clamps solid	146-162
H	
Hinge clamps light	45-47
Hinge clamps solid	176-196
How to use	2
I	
Inclining adaptor	300
Industrial design solid clamps	66-70, 82-85, 104-111, 126, 134-135, 144
infovan.....	6
Insert clamps.....	122-130
Insert nut	233
Internal tension system ITAS	240-248
ITAS	234-265
ITAS overview	20
L	
Level of service	8
Light Clamps	14, 24-55
LINEAR TECHNOLOGY	5
Loads angle clamps solid	79
Loads base clamps solid	101
Loads cross clamps solid	63
Loads flange clamps solid	147
Loads hinge clamps solid	177
Loads insert clamps solid	123
Loads ITAS	239
Loads light clamps	29
Loads parallel clamps solid	141
Loads robust clamps	211
Loads sleeve clamps solid	131
Loads strap clamps solid	165



M

MODULE TECHNOLOGY 5

Monitor mounting 268

Monitor floor stand 300

Multi-piece elements light clamps 28

Multi-piece elements solid clamps
..... 62, 78, 100, 122, 130 , 146, 164, 176

O

Online selection guide 23

Order information light clamps 30

Our product range 5

P

Parallel clamps solid 140-145

Phoenix Mecano 4

PROFILE TECHNOLOGY 5

pull-back spring 249

Q

quad elements 75-77, 94-99, 120-121,
..... 129, 136-139, 158-162,

Quick change system ITAS 250-254

R

Reducing bushes light clamps 30

Resistance to chemicals 56

Right angle tube connector light clamps 26, 32

Right angle tube connector robust clamps
..... 208, 212

Right angle tube connector solid clamps
..... 60, 64, 80, 102, 124, 212

RK monitor mounting 268-281

Robust Clamps 206-217

Robust Clamps overview 18

Round tube stopper 228

S

Sectional views hinge clamps 197

Selection guide 8-23

Single-piece elements light clamps 28

Single-piece elements solid clamps 62, 78, 100,
..... 122, 130, 140, 146, 164, 176 , 210

Site plate 261

Sleeve clamps light 40

Sleeve clamps solid 130-139

Smartphone holder 287

Solid Clamps 58-197

Solid Clamps overview 16

Special tube fittings 229

Spring-return 249

Square Connecting tubes 50 60 80 313

Square tube stopper 228

Stainless steel tubes 222

Stair corner joint 263

Stair cross beam profile 259

Stair joint 262

Stair railing support 248

Steel tubes 222

Step profile 260

Strap clamps light 43-44

Strap clamps solid 164-175

T

Table of contents accesories 221

Table of contents ITAS 237

Table of contents light clamps 27

Table of contents robust clamps 209

Table of contents solid clamps 61

Technical data ITAS 238

Threaded stopper round tube 227

Threaded stopper square tube 227

T-joint 242, 244

Tools / spare parts 263

Twisting moment 29, 63, 79, 101, 123,
..... 131, 141, 147, 165, 177, 211

W

Wall flange 248

Website 6

What is Connecting Technology 10

What we can do for you 6