

LH15 Electric cylinder

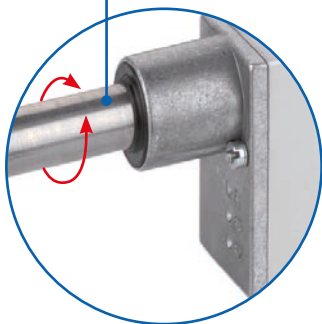

Adjustable stroke lengths

- ✓ Precise adjustment

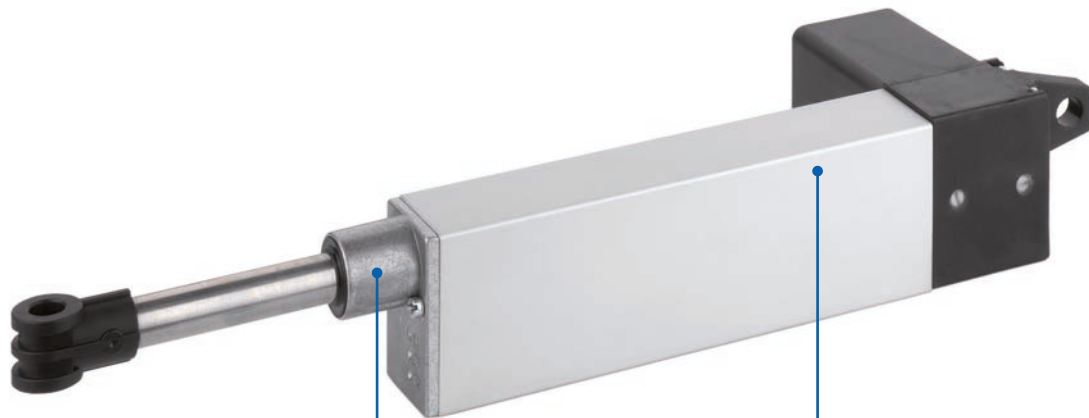
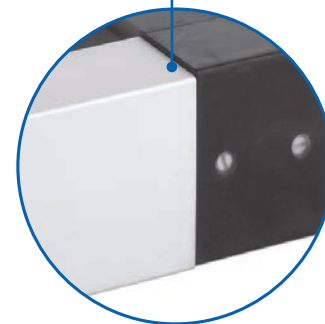

Corrosion-protected

- ✓ Stainless-steel spindle
- ✓ Housing made of aluminium and plastic

Features:

- Outstanding for industrial applications
- High max. lifting speed
- Integrated overcurrent protection
- Maintenance-free (permanent lubrication)
- Corrosion-protected, thanks to stainless-steel spindle and push rod; housing made of aluminium and plastic
- Rugged design
- Integrated limit switches
- Adjustable travel

Options:

- Special stroke lengths
- Potentiometer
- Signal contacts
- Higher protection class with bellows

General information/operating conditions

	Drive
Design	Linear cylinder with integrated DC motor
Guide	Slide bush
Installation position	Any position, without shear forces
Push force/Pull force	Up to 1,000 N
Self-locking	Up to 2,000 N
Ambient temperature	-20°C to +60°C
Repeatability	0.5 mm
Duty cycle (at max. load)	10% at nominal load (max. 2 mins operating time, 18 mins rest time)
Voltage	24 (12) V DC
Current output	Max. 2.2 (4.5) A
Power input	Max. 50 W
Protection class	IP 54

LH15 Electric cylinder - Versions

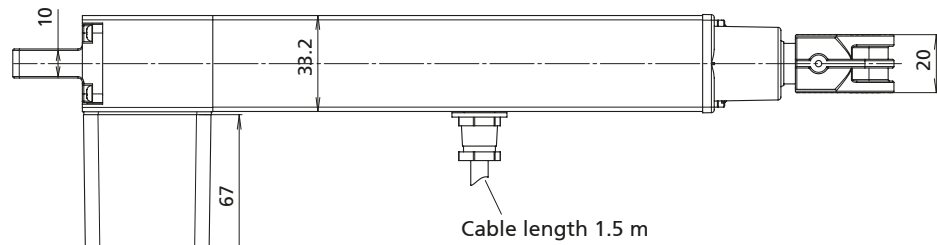
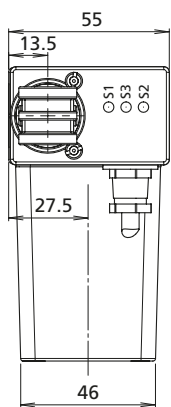
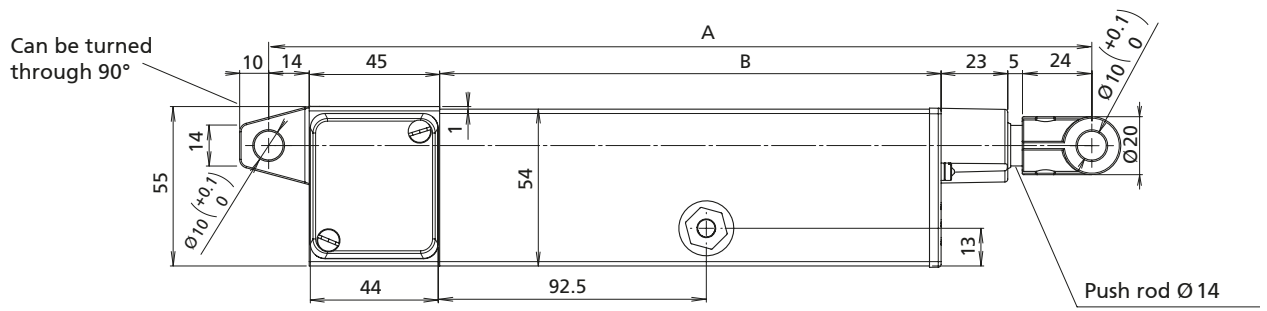

Code No.	Type	Max. force F [N]	Max. speed [mm/s]
QKD05_F010_ _ _	LH15	1,000	5
QKD10_E010_ _ _		600	10
QKD22_C010_ _ _		300	22
QKD25_D010_ _ _		450	25
QKD60_B010_ _ _		200	60
QKD01_A010		60	100

Standard stroke lengths

Stroke [mm]	Stroke can be externally adjusted	Dimension A [mm]	Dimension B [mm]	Weight [kg]
100	Yes	284	173	1.2
140	No	284	173	

Special stroke lengths available on request

Stroke [mm]	Stroke can be externally adjusted	Dimension A [mm]	Dimension B [mm]	Weight [kg]
140	Yes	324	213	1.2
260		444	333	
180	No	324	213	
300		444	333	

B = 24 V DC
C = 12 V DC