

Original version of assembly instructions



For	Components					
	Short	Long	Compact	Short	Long	Compact
Spieth clamping set (precision clamping sets)	-	DSM 14.2	-	DSM 40.1	DSM 40.2	DSM 40.56
	DSM 16.1	DSM 16.2	DSM 16.28	DSM 42.1	DSM 42.2	DSM 42.58
	-	DSM 18.2	DSM 18.30	DSM 45.1	DSM 45.2	DSM 45.62
	DSM 19.1	DSM 19.2	DSM 19.32	DSM 48.1	DSM 48.2	DSM 48.65
	DSM 20.1	DSM 20.2	DSM 20.32	DSM 50.1	DSM 50.2	-
	DSM 22.1	DSM 22.2	DSM 22.35	DSM 55.1	DSM 55.2	-
Series	DSM 24.1	DSM 24.2	DSM 24.36	DSM 60.1	DSM 60.2	-
DSM	DSM 25.1	DSM 25.2	DSM 25.37	DSM 65.1	DSM 65.2	-
	DSM 28.1	DSM 28.2	DSM 28.40	DSM 70.1	DSM 70.2	-
	DSM 30.1	DSM 30.2	DSM 30.42	DSM 75.1	DSM 75.2	-
	DSM 32.1	DSM 32.2	DSM 32.48	DSM 80.1	-	-
	DSM 35.1	DSM 35.2	DSM 35.52	DSM 85.1	-	-
	DSM 38.1	DSM 38.2	DSM 38.55			

The Assembly Instructions are also available for download at www.spieth-me.de.
 In case of any questions, please contact Spieth-Maschinenelemente GmbH & Co. KG directly.

Legal:

SPIETH-MASCHINENELEMENTE GmbH & Co. KG, Alleenstraße 41, D - 73730 Esslingen
 Phone +49 711 930730 0 - Fax +49 711 930730 7
 E-Mail: info@spieth-me.de - Web: www.spieth-me.de
 KG: Esslingen HQ, Stuttgart county court, company register sect. A 210689
 PhG: Spieth-Beteiligungs-GmbH, Esslingen HQ, Stuttgart county court, company register sect. A 210636
 Managing director: Dipl.-Ing. Alexander Hund

©Spieth Proprietary notice ISO 16016	Previous document: ma-dsm-en1817	See
	Successive document: N/A	www.spieth-me.de/english/service-download/catalogue-instructions/
	Created: 03 May 2018/Fd	For any questions, requests or suggestions, please contact
	Checked: 03 May 2018/Ax	info@spieth-me.de

Assembly instructions for Spieth clamping sets

Table of Contents

Assembly instructions for Spieth clamping sets		2
Table of Contents		2
1 Information about Spieth Clamping Sets		3
1.1 General information		3
1.2 Safety notices		3
2 Description of Spieth Clamping Sets.....		4
2.1 Structure.....		4
3 Assembling Spieth Clamping Sets.....		4
3.1 Preparing for assembly.....		4
3.2 Ambience.....		5
3.3 Assembly process		5
4 Disassembling Spieth Clamping Sets		6
5 Maintenance and servicing of Spieth clamping sets		7

©Spieth Proprietary notice ISO 16016	Previous document: ma-dsm-en1817	See
	Successive document: N/A	www.spieth-me.de/english/service-download/catalogue-instructions/
	Created: 03 May 2018/Fd	For any questions, requests or suggestions, please contact
	Checked: 03 May 2018/Ax	info@spieth-me.de

1 Information about Spieth Clamping Sets

1.1 General information

Spieth clamping sets are precision parts and require careful handling. Follow the information in these assembly instructions and the operating instructions. Failing to comply with them may significantly impact functionality and service life.

To initiate clamping, use only original Spieth clamping screws. Only actuate the clamping screws if borehole and outer surfaces of the clamping set are fully covered by the connecting components. Otherwise, damage such as plastic deformation may occur on the clamping sleeve and render it unusable.

Spieth-Maschinenelemente GmbH & Co. KG assumes no liability for damage from improper handling, incorrect installation, or unauthorised structural changes.

1.2 Safety notices

Spieth clamping sets are intended for use with friction-locked shaft-hub connections. Please follow all relevant safety notices.

Caution!

Any work carried out with or on the clamping set needs to follow the "safety first" guideline!

During operation, keep your hands away from the working area of the the clamping set!

Prior to any assembly work, switch off all machine drives!

Secure the machine against accidental power-up!

Prior to commissioning the machine, install all safety devices!

Only expert personnel are allowed to perform assembly work on Spieth clamping sets. Using Spieth clamping sets is only admissible according to specifications. Spieth-Maschinenelemente GmbH & Co. KG assumes no liability for violations of the operating instructions or safety notices. This also applies to incorrectly interpreting or circulating these notices and to incorrect assembly or maintenance.

The clamping sleeves described here are state of the art at the time these assembly instructions are printed. Subject to changes based on evolved technologies.

For international deliveries, follow the safety regulations applicable in the target country.

©Spieth Proprietary notice ISO 16016	Previous document: ma-dsm-en1817	See
	Successive document: N/A	www.spieth-me.de/english/service-download/catalogue-instructions/
	Created: 03 May 2018/Fd	For any questions, requests or suggestions, please contact
	Checked: 03 May 2018/Ax	info@spieth-me.de

2 Description of Spieth Clamping Sets

2.1 Structure

Spieth clamping sleeve
Spieth clamping screws

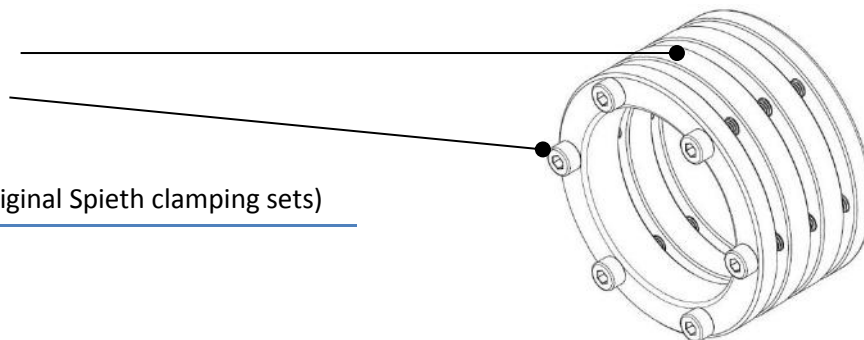

Identifying features (for original Spieth clamping sets)

Spieth logo

Name

Batch number

Pretensioning torque M_v of the clamping screws

Fig. 1: Schematic representation similar to Spieth DSM series clamping sets

Spieth DSM series clamping sets have been designed according to DIN 748 for use on motor shafts with k6- and/or m6-tolerance zone. The assembly consists of a clamping sleeve and clamping screws for integrated clamping initiation. In contrast to tapered clamping sets, the one-piece cylindrical clamping sleeve has no tolerance-heavy joints and can therefore achieve a higher degree of precision.

3 Assembling Spieth Clamping Sets

3.1 Preparing for assembly

Remove Spieth clamping sets from their packaging right before assembly. As hand perspiration can cause corrosion, ensure to keep your hands dry and clean and/or to always wear protective gloves for assembly.

Please note:

For environmental reasons, please comply with applicable statutory regulations and guidelines when disposing of packaging materials.

In case of damage to packaging components, check the clamping sets for damage and remove any contamination. The preservative used is compatible with all conventional machine oils. If in doubt, check the preservative's compatibility.

For an optimum mode of action of Spieth clamping sets, remove the thin wax-like film of preservative from the contact surfaces using a lint-free cloth. Directly afterwards, use machine oil without friction-reducing additives to lightly oil the component and protect it from corrosion.

3.2 Ambience

During assembly, ensure that...

- the assembly location is free from dust and clean,
- the components have no contact with corrosive media,
- foreign bodies such as sand, sawdust, fluff, etc. are kept away from the component,
- metal filings (in particular from machining tools such as files, etc.) are kept away from the component.

Caution!

Contamination can significantly impact the functionality and service life of Spieth clamping sets.

For best results, use a suitable, enclosed space for assembly and proceed swiftly. If this is not possible, make sure to protect the components from ambient contamination and from damage.

3.3 Assembly process

Essentially, assembly is a 4-step process:

- 1. Cleaning and oiling
- 2. Joining
- 3. Removing clearance
- 4. Clamping initiation

For an optimum mode of action of Spieth clamping sets, perform all four assembly steps in the specified order.

Caution!

To initiate clamping, use only original Spieth clamping screws. Only actuate the clamping screws if borehole and outer surface of the clamping set are fully covered by the connecting components.

Otherwise, damage such as plastic deformation may occur on the clamping sleeve and render it unusable.

In such a case, Spieth-Maschinenelemente GmbH und Co. KG assumes no liability or warranty.

Use only the following assembly process for assembling Spieth DSM series clamping sets:

3.3.1 Cleaning and oiling:

For optimum application, carefully clean clamping set, shaft and hub borehole and lightly dab them with conventional fluid machine oil without friction-reducing additives.

3.3.2 Joining:

Join clamping set and connecting components without applying too much force to ensure that the clamping set contact surfaces are fully covered.

3.3.3 Removing clearance:

Tension the clamping screws crosswise and stepwise until you have fully removed the clearance with hub and shaft. Uniform removal of clearance is particularly important for good radial run-out.

©Spieth Proprietary notice ISO 16016	Previous document: ma-dsm-en1817	See
	Successive document: N/A	www.spieth-me.de/english/service-download/catalogue-instructions/
	Created: 03 May 2018/Fd	For any questions, requests or suggestions, please contact
	Checked: 03 May 2018/Ax	info@spieth-me.de

3.3.4 Clamping initiation:

Continue to tighten clamping screws evenly and repeatedly, crosswise and stepwise until applying the full torque (see design guide/see note). Only tension Spieth clamping sets if using original Spieth clamping screws and once borehole and outer surface of the clamping sleeves are fully covered by shaft and hub. Then check pretensioning torque M_v all across.

In case of maximum demands on hub-shaft concentricity you can individually adjust the clamping screws to achieve the desired result.

Please note:

During the clamping process, the clamping sleeve shrinks by a few tenths of a mm, which, despite a symmetrically acting operating force from the clamping screws, can result in a minor axial displacement of the clamped part in undefined direction.

Afterwards, check the tightening torque of the clamping screws all across.

Following specified assembly, Spieth clamping sets are ready for use immediately.

Please see the relevant assembly instructions, available at www.spieth-me.de, for more information on assembly.

4 Disassembling Spieth Clamping Sets

If handled correctly, Spieth clamping sets can be reused several times. Undo the clamping screws to return the cylindrical clamping set into its original shape.

In case you used a Spieth clamping set to friction-lock a shaft and a hub, due to the adjustments made you can only reconnect these two components after they have been disassembled.

Caution!

Undo all the clamping screws stepwise and crosswise to avoid overstraining the screws. Otherwise, the screws may fracture or the clamping set or adjoining components may be damaged.

To disassemble, proceed in reverse assembly order.

- 1. Remove the clamping force by undoing the clamping screws stepwise and crosswise.
- 2. After undoing the clamping screws, all parts of the connection regain their free movement.

Please note:

Following several assembly processes, the friction conditions on the clamping screws between upper and contact surfaces may change unfavourably. Tightening may result in stick-slip effects, resulting in erratic movements (cracking) of the clamping screws. In that case, first relubricate the screwhead support using normal machine oil without additives. If the stick-slip effects persist, replace the clamping screws by new original Spieth clamping screws.

©Spieth Proprietary notice ISO 16016	Previous document: ma-dsm-en1817	See
	Successive document: N/A	www.spieth-me.de/english/service-download/catalogue-instructions/
	Created: 03 May 2018/Fd	For any questions, requests or suggestions, please contact
	Checked: 03 May 2018/Ax	info@spieth-me.de

Please note:

Following complete disassembly, slightly (manually) tighten the loosened clamping screws until they are flush. In any case, avoid tightening the clamping screws without fully covered contact surfaces of the clamping set.

To enable later reuse, clean, preserve, and store Spieth clamping sets correctly. Prior to reuse, proceed as detailed in Section 3.1, "Preparing for assembly" ff.

If non-original Spieth spare parts are used, Spieth-Maschinenelemente GmbH & Co. KG assumes no liability or warranty.

5 Maintenance and servicing of Spieth clamping sets

Spieth clamping sets are maintenance-free. During general maintenance work, we nevertheless recommend visually inspecting the clamping set and checking pretensioning torque M_V of the clamping screws. If used as intended, Spieth clamping sets and their high level of concentricity accuracy result in a friction-locked shaft-hub-connection for high torque values and axial forces.

Follow general safety notices when using Spieth clamping sets.

Caution!

Never touch actively rotating components. Take protective measures against accidental contact.

If you notice irregularities with the Spieth clamping sets during operation, immediately switch off the machine's drive.

©Spieth Proprietary notice ISO 16016	Previous document: ma-dsm-en1817	See
	Successive document: N/A	www.spieth-me.de/english/service-download/catalogue-instructions/
	Created: 03 May 2018/Fd	For any questions, requests or suggestions, please contact
	Checked: 03 May 2018/Ax	info@spieth-me.de