

SeGMO-Motion

Compact positioning drive for cyclic operation

GEL 6108

Technical information

Version 2019-09

General

The SeGMO-Motion GEL 6108 forms a compact mechatronic unit comprising a DC brushless motor, a 32-bit microprocessor, a compact power amplifier as well as a spur gear with a nominal torque of 0.4 Nm.

The SeGMO-Motion GEL 6108 is suitable for cyclic operation at 0.25 Nm, 50 % duty cycle and a cycle time of 1 s.

This positioning drive is equipped with a robust, incremental measuring system. The position of the shaft can be referenced once per turn via an optional proximity switch input. Active system protection against thermal overload and comprehensive system software ensure durable operation.

Features

- Spur gear: 0.4 Nm nominal torque (duty cycle 25 %)
- Stainless steel housing, glass-bead blasted, Viton sealed
- Operating temperature
 - At ED 25 % with 0.4 Nm: 0 °C to +60 °C
 - At ED 50 % with 0.25 Nm: 0 °C to +50 °C
- DCBL motor
- Hybrid cable outlet
- CANopen DS 402
- High protection class IP 67
- Gear service life

Advantages

- Suitable for cyclic operation at 0.25 Nm and ED 50 % and 1 s cycle time
- Flexible installation variants make cleaning of all external parts straightforward
- Maintenance-free due to sealed-for-life lubrication
- Straightforward installation matched to the application

Fields of application

- Packaging machines
- Food and bottling plants
- Wood and plastic working machines



Description

Construction

The positioning drives in the series GEL 6108 are intelligent mechatronic units for attachment to solid shafts. The installation of the GEL 6108 is flexible and is adapted to the application. For easier cleaning of the external parts, rotating or removable housing mounting is possible. The stainless steel housing is glass-bead blasted and laser welded. Equipped with a Viton shaft sealing ring, the GEL 6108 meets protection class IP 67. The GEL 6108 provides a nominal torque of 0.4 Nm at 750 min⁻¹ via a compact spur gear. In cyclic operation it provides a torque of 0.25 Nm with a duty cycle of 50 % and a cycle time of 1 s. It is operated with a supply voltage of 24 V DC and supports the fieldbus profile CANopen DS402.

The GEL 6108 is designed for connection to the SeGMo-Box. It is supplied with a hybrid cable outlet or hybrid connector.

The positioning drive acquires the position using an integrated incremental, magnetic sensor. This sensor is extremely robust and withstands high shock and vibration loads. The position of the shaft is referenced once per turn via a proximity switch input.

The hybrid cable and M12 connector for the proximity switch input are on the underside of the housing. On the rear there is a USB port behind the blanking plug. A pressure equalisation valve can also be fitted.

The optional pressure equalisation valve permits the exchange of air and other gases between the interior of the housing and the surroundings. The design prevents the ingress of liquids, dust and particles of dirt.

Modes of operation

The drive is designed for cyclic short-time operation at nominal torque. The following intervals are valid:

- ED = 25 % in an operating interval of 4 minutes with 0.4 Nm (nominal torque)
- ED = 50 % in an operating interval of 1 second with 0.25 Nm

Other methods of operation are protected by I²t and temperature monitoring.

Reliability

Important parameters such as motor power and device temperature are monitored and in this way the positioning drive actively protected against overload. The following monitoring devices ensure trouble-free operation:

- Soft start and shutdown via acceleration and deceleration ramps
- Over/undervoltage detection on the drive and logic supply
- Lag error detection
- Temperature monitoring on the power amplifier and inside the housing
- Motor and power amplifier overload protection via I²t monitoring

System solution

In combination with the SeGMo-Box GEL 65xx, Lenord + Bauer offers a system solution for the GEL 6108. The power supply and the required interface profile for the positioning drives are configured via the hybrid cable SeGMo-Connect using the SeGMo-Box. The hybrid cable SeGMo-Connect suitable for use in drag chains makes possible straightforward connection technology.

General information on SeGMo-Connect

The hybrid cable SeGMo-Connect is designed for flexible application in drag chains. It is available in the foodgrade, halogen-free and cULus recognised variants. The hybrid cable is screened under the outer sheath. The internal communication cores are fully insulated and multiply screened.

All positioning drives are available with hybrid cable and connectors and can be connected quickly and straightforwardly to the SeGMo-Box via the pre-assembled hybrid connecting cables that can be configured as required. Connectors with a quick-release coupling permit quick connection and disconnection. The positioning drive is therefore reliably and quickly disconnected from the power supply for maintenance and service work in a matter of seconds. Pre-assembled connection cables are available for the connection, see "Technical information BZK".

Technical data

Electrical data	
Nominal voltage control system	24 V DC -5 % / +20 %
Nominal voltage motor	24 V DC -5 % / +20 % (Attention: max. motor speed is voltage dependent!)
Nominal current control system	Max. 400 mA, internal fuse, self-resetting
Nominal current motor	3 A, maximum current 5 A, external fuse required
Duty cycle (load-dependent)	ED = 25 % at 100 % load torque, short-time duty S2, (base time 4 minutes: ED = 1 minute, PD ⁽¹⁾ = 3 minutes) ED = 50 % at 0.25 Nm, dependent on ambient parameters and application
Position actual value resolution	96 increments per 360° 120 increments per 360° (with internal multiplier)
Positioning accuracy	±7.5°
Repeat accuracy	±3.75°
Interfaces	CANopen (DS-402) further interfaces using SeGMO-Box GEL 65xx
Dielectric strength (DIN EN 60439-1)	500 V DC
EMC ⁽²⁾	Electromagnetic immunity EN 61000-6-1:2007-10 / EN 61000-6-2:2006-03 Electromagnetic emissions EN 61000-6-3:2011-09 / EN 61000-6-4:2011-09
Mechanical data	
Nominal torque output shaft	Max. 0.4 Nm at 750 min ⁻¹
Gear service life at nominal load (for nominal torque)	L _{10h} : 10,000 h
Output shafts	Solid shaft, 5 mm outside diameter
Max. shaft load (axial/radial)	30 N / 50 N
Housing material	Stainless steel 1.4301
Weight	1.25 kg
Protection class (EN 60529)	IP 67 with shaft sealing ring made of Viton
Shock resistance (DIN EN 60068-2-27)	150 m/s ² (approx. 15 g)
Vibration resistance (DIN EN 60068-2-6)	50 m/s ² (approx. 5 g) at 55 Hz
Ambient data	
Assured operating temperature range	At ED 25 % with 0.4 Nm: 0 °C to +60 °C At ED 50 % with 0.25 Nm: 0 °C to +50 °C
Operating temperature range	-10 °C to +60 °C
Storage temperature range	-20 °C to +85 °C
Max. relative humidity of air	95 %
Condensation	Not permitted pressure equalisation valve optional ⁽³⁾

(1) PD length of space

(2) Use only screened cables.

(3) Optional, see type code: Option package

Technical data

Technical data, cables

Hybrid cable	Design 0 (standard)	Design 1 (UL/CSA hybrid cable)
Sheath material	PUR, black, glossy	PUR, black, matt
Cable properties	Screened	Screened
Suitable for drag chains	Yes	Yes
Food grade	Yes	No
Halogen-free	No	Yes
Cable diameter (d)	9.5 mm	9.5 mm
Bending radius	Permanently flexible: 10 × d Fixed routing: 5 × d	Permanently flexible: 15 × d Freely moving: 10 × d Fixed routing: 5 × d
Peak operating voltage	Max. 350 V CAN bus Max. 30 V DC (logic / power)	Max. 300 V CAN bus Max. 30 V DC (logic / power)
Temperature range	-40 °C to +80 °C	-40 °C to +80 °C

Hybrid cable SeGMo-Connect⁽¹⁾

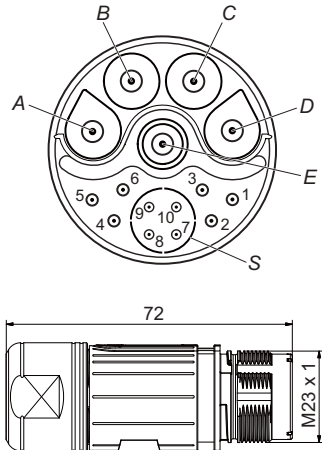
With M23 connector/option H1 - Hx	Flying lead/option xx		Assignment	
Male coupling	Pin	Core colour		Cross-section [mm ²]
	A	red	0.5	+24 V control system
	B	black	0.5	GND control system
	C	black	1.5	GND motor
	D	red	1.5	+24 V motor
	E	–	–	Cable screen
	7	yellow	0.25	CAN_H
	8	black	0.14	CAN GND
	9	green	0.25	CAN_L
	S	–	–	CAN screen

Proximity switch input⁽²⁾

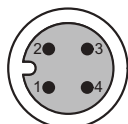
Connector	Pin	Assignment
 Female M12, 4-pin, A-coded	1	+ 24 V DC (output)
	2	n.c.
	3	GND
	4	Signal

(1) Configurable connecting cables are available for the connection, see "Technical information BZK".

(2) Optional, see type code: Option package

Dimensional drawings

Dimensional drawing – GEL 6108

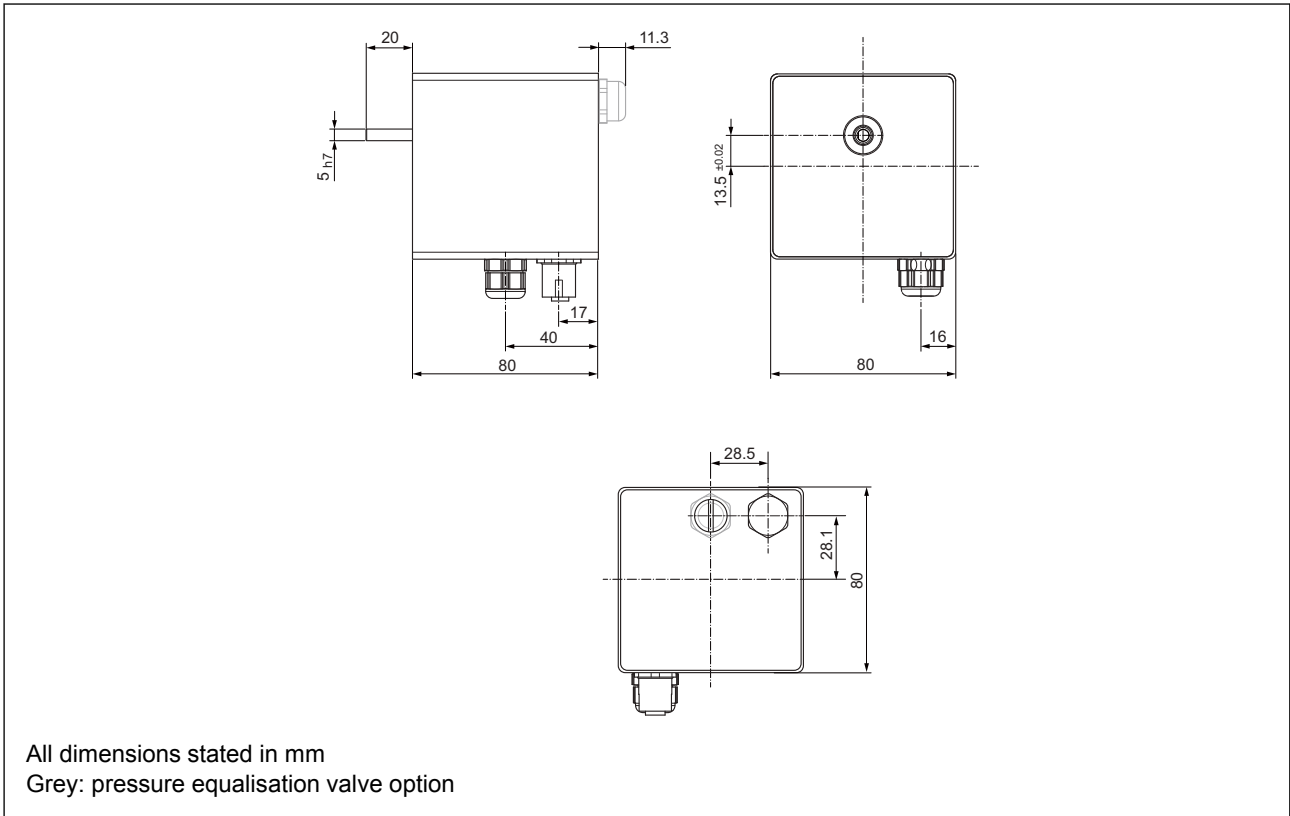

Dimensional drawings – torque supports

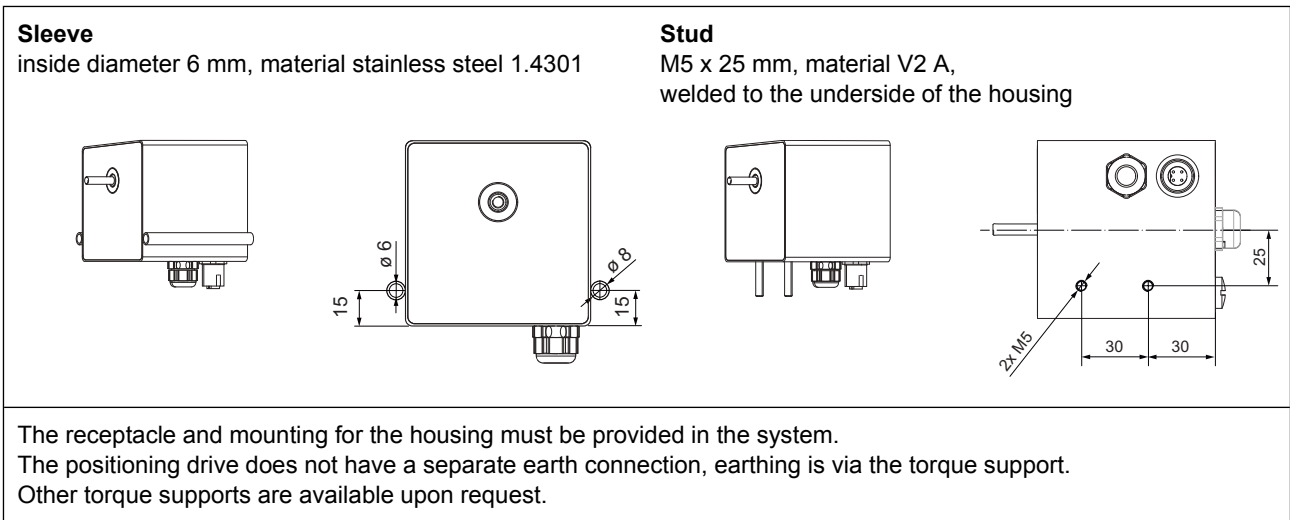

Type code GEL 6108

	Interfaces	
	CO	CANopen DS 402
	Nominal torque	
	04	0.4 Nm / 750 min ⁻¹ at duty cycle 25 %
	Shaft [in mm]	
	A	Solid shaft, outside diameter 5 mm
	Housing	
	E	Stainless steel 1.4301
	Torque support	
	1	Sleeves, 2 pieces, inside diameter 6 mm
	2	Studs, 2 pieces, M5 x 25 mm
	Hybrid cable/connector	
	xx	Hybrid cable with flying lead, length of the cable in m, 03 minimum length 3 m, 20 maximum length 20 m
	H1	Hybrid cable (length 30 cm) with M23 connector, male coupling ⁽¹⁾
	H2	Hybrid cable (length 50 cm) with M23 connector, male coupling ⁽¹⁾
	H3	Hybrid cable (length 100 cm) with M23 connector, male coupling ⁽¹⁾
	Hx	Hybrid cable (length xx cm) with M23 connector, male coupling ⁽¹⁾
	Sensor	
	I	Incremental sensor with 96 increments per turn
	Version	
	0	With standard components
	1	With UL/CSA hybrid cable
	Option package	
	A	Proximity switch input (M12 connector) and pressure equalisation valve
6108	—	—

⁽¹⁾ Configurable connecting cables are available for the connection, see "Technical information BZK".



Lenord, Bauer & Co. GmbH
Dohlenstraße 32
46145 Oberhausen, Germany
Phone: +49 208 9963-0
Fax: +49 208 676292
Internet: www.lenord.com
E-Mail: info@lenord.de

Right to technical changes and errors reserved.