

General

The SeGMO-Positioning forms a compact mechatronic unit comprising a brushless DC motor, a 32-bit microprocessor, a compact power amplifier and a powerful gear, as well as a magnetic multiturn encoder.

Active system protection against thermal overload and comprehensive system software allow load-dependent duty cycles well above 25 %.

The robust stainless steel housing with its high degree of protection (IP67) is suitable for a wide range of applications in various industrial areas. Alternatively a rigid aluminium housing also with degree of protection IP67 is available.

Features

- Nominal torques from 1.4 Nm to 15 Nm
- Housing made of stainless steel or aluminium
- Operating temperature -10 °C to +60 °C
- BLDC motor
- Magnetic-absolute multiturn encoder
 - Detection range: 342 turns, also in de-energised state
- Degree of protection IP67
- Integrated communication interfaces
 - CANopen (CiA 402); PROFIBUS-DP (V0/V1); Sercos III;
 - POWERLINK; PROFINET IO / RT; EtherCAT; EtherNet/IP;
 - Modbus/TCP
- Optionally with cULus component recognition

Advantages

- Either hybrid cable or plug outlet
- Onboard joystick for straightforward commissioning
- Monitoring of important system parameters ensures reliable operation (overload protection)
- Ready for use immediately after power on due to absolute multiturn position detection
- Maintenance-free due to sealed-for-life lubrication

Fields of application

- Packaging machines
- Food and bottling plants
- Wood and plastic working machines
- Printing presses and book binding machines
- Extensive production plants



Variable type of connection and interface

Right to technical changes and errors reserved.

Description

System concept

The positioning drives belong to the product group SeGMo-Positioning and are a component of the SeGMo-System.

Each positioning drive in the GEL 6110 series is an intelligent adjustment unit for pushing onto the end of a shaft or for attachment to a shaft or spindle.

The positioning drive can be integrated directly into a plant control system via the communication interfaces integrated.

SeGMo-System

The SeGMo-System is suitable for the efficient integration of several positioning drives in a machine or plant. The system consists of the following components:

- SeGMo-Positioning:
Positioning drive for fully automatic format adjustment
- SeGMo-Motion:
Positioning drive for cyclic operation
- SeGMo-Box:
Decentral control unit for up to 5 drives
- SeGMo-Connect:
Single cable concept (hybrid cable suitable for drag chain)
- SeGMo-Lib:
Ready-made function blocks for integration in the machine control system
- SeGMo-Support Tool:
Software for advanced commissioning and configuration

The usage of SeGMo-Box and SeGMo-Connect significantly reduces the cabling effort for the positioning drives. Instead of the usual two separate cables for internal bus communication and a third cable to supply power to the positioning drives, only **ONE** hybrid cable suitable for use in drag chains is connected. In the maximum configuration with 5 positioning drives connected, the number of cables typically reduces from 15 to 5 due to SeGMo-Connect. With the aid of the SeGMo-Box the overall system offers a high degree of flexibility during integration, as it supports all common communication interfaces.

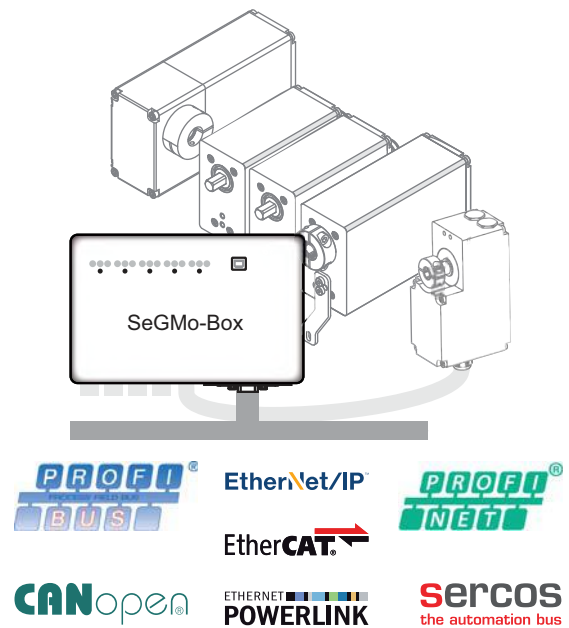

On usage with the SeGMo-Box all common communication interfaces are available

Construction

The positioning drive is operated with a supply voltage of 24 V DC and supports fieldbus profiles (CANopen (CiA 402); PROFIBUS-DP (V0/V1)) and Industrial Ethernet protocols (Sercos III; POWERLINK; PROFINET IO / RT; EtherCAT; EtherNet/IP; Modbus/TCP). SeGMo-Connect is available with either a plug connection or hybrid cable.

The positioning drive is equipped with mechanical manual adjustment so that the positioning drive can be actuated if there is a fault, e.g. a power failure.

The mechanical manual adjustment is not allowed to be actuated on devices with the holding brake option, this will cause damage to the device!

The optional holding brake guarantees secure retention even if there are shock and vibration loads, especially on vertical feed axes.

A USB service connector is accessible on the rear of the device for service purposes.

The device variants with integrated fieldbus (CANopen (CiA 402); PROFIBUS-DP (V0/V1)) have rotary selection switches for setting the device ID and baud rate, as well as an onboard joystick. The positioning drive can be operated in the set-up mode using the joystick without prior PLC programming. All elements are accessible on the rear of the device.

Integrated absolute rotary encoder

A magnetic-absolute multiturn rotary encoder makes reference search routines after a power failure or emergency stop unnecessary. Due to the batteryless encoder, the positioning drive detects its position after power on and is immediately ready for use.

In the switched off state the drive shaft can be moved by ± 171 turns without loss of the absolute position.

The absolute rotary encoder withstands high shock/ vibration loads.

General information on SeGMo-Connect

The hybrid cable SeGMo-Connect is designed for flexible application in drag chains. It is available in the foodgrade, halogen-free and cULus recognised variants. The hybrid cable is screened under the outer sheath. The internal communication cores are fully insulated and multiply screened.

All positioning drives are available with hybrid cable and connectors and can be connected quickly and straightforwardly to the SeGMo-Box via the pre-assembled hybrid connecting cables that can be configured as required.

Connectors with a quick-release coupling permit quick connection and disconnection. The positioning drive is therefore reliably and quickly disconnected from the power supply for maintenance and service work in a matter of seconds. Pre-assembled connection cables are available for the connection, see "Technical information BZK".

Mounting

The mounting concept comprises a fixed-moving bearing. The machine shaft supports the weight of the positioning drive via the fixed bearing. For this purpose the positioning drive is mounted directly and positively on the machine shaft using a clamped connection with a form-fit, for example over a hollow shaft with a clamping ring. The torque support prevents the positioning drive rotating and, as the moving bearing, compensates for any movements that occur on the drive shaft due to imbalance, if necessary. The shape and design of the torque support are order-specific. Various accessories are available for mounting.

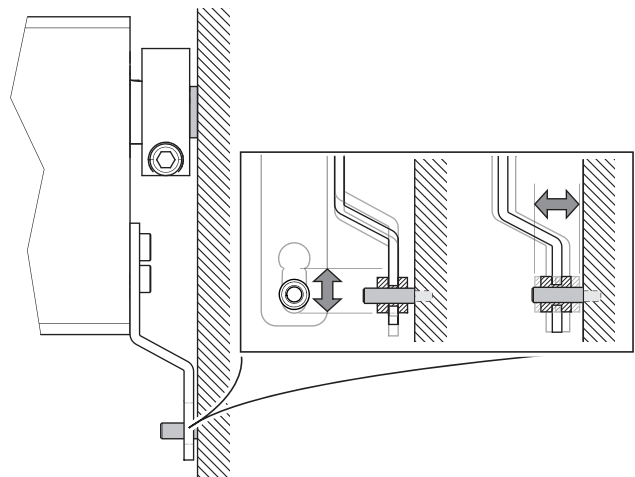

Absorbing imbalance movements at the moving bearing

Mounting position

The SeGMo-Positioning GEL 6110 is mounted with the narrow side horizontally or vertically to the shaft. The drive shaft (fixed bearing) and the attachment point of the torque support (floating bearing) must be aligned to keep the mechanical stresses on all components as small as possible.

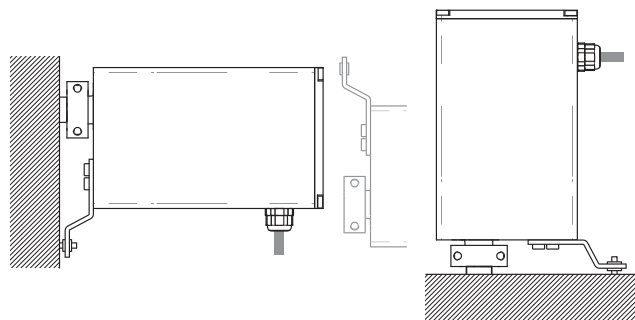

Permissible mounting position: horizontal (left) and vertical (right)

An assembly in transverse position with the wide side up is **not allowed**.

Description

Modes of operation

The drive is designed for positioning at nominal torque.

The following intervals are valid for a duty cycle (ED) of

- Duty cycle = 25 % at 100 % load torque, positioning mode S2
(base time 4 minutes: ED = 1 minute, PD = 3 minutes)
- Duty cycle ≤ 50 % with reduced load torque, dependent on ambient parameters and application

Other methods of operation are protected by I^2t and temperature monitoring as well as an adjustable current limit. This protection permits a briefly increased breakaway torque.

Reliability

Important parameters such as motor power and device temperature are monitored and in this way the positioning drive actively protected against overload. The following monitoring devices ensure trouble-free operation:

- Soft start and shutdown via acceleration and deceleration ramps
- Over / undervoltage detection on the power circuit supply and logic circuit supply
- Lag error detection (drive shaft in relation to motor shaft)
- Temperature monitoring on the power amplifier and inside the housing
- Motor and power amplifier overload protection via I^2t monitoring and in combination with the box by means of the maximum current.

Technical data

Nominal torque (housing size)	01 (K)	02 (L)	03 (K)	05 (L)	07 (K)	10 (L)	15 (L)
Electrical data							
Nominal voltage logic circuits	24 V DC -5% / +25%						
Nominal voltage power circuits	24 V DC -5 % / +25% (Attention: max. motor speed is voltage dependent!)						
Nominal current logic circuits	Max. 400 mA, external fuse required						
Nominal current power circuits (1)	2.5 A (max. 7 A)	3.5 A (max. 7.5 A)	2.6 A (max. 7 A)	3.6 A (max. 7.5 A)	2.2 A (max. 7 A)	3.1 A (max. 7.5 A)	
Duty cycle in % (load-dependent)	Duty cycle = 25 % at 100 % load torque, positioning mode S2 (base time 4 minutes: ED = 1 minute, PD ⁽²⁾ = 3 minutes) Duty cycle ≤ 50 % with reduced load torque, dependent on ambient parameters and application						
Positioning range	Unlimited ⁽³⁾						
Fieldbus interfaces	CANopen (CiA 402); PROFIBUS-DP (V0/V1)						
Industrial Ethernet	Sercos III; POWERLINK; PROFINET IO / RT; EtherCAT; EtherNet/IP; Modbus/TCP						
Dielectric strength	√2 × 500 V DC; as per DIN EN 61439-1:2012-06						
EMC ⁽⁴⁾	Electromagnetic immunity EN 61000-6-1:2007-10 / EN 61000-6-2:2006-03 Electromagnetic emissions EN 61000-6-3:2011-09 / EN 61000-6-4:2011-09						
Encoder data							
Resolution	1000 increments per 360°						
Detection range	342 turns, also in de-energised state						
Mechanical data							
Nominal torque drive shaft	1.4 Nm at 230 min ⁻¹	2 Nm at 230 min ⁻¹	3.5 Nm at 100 min ⁻¹	5 Nm at 100 min ⁻¹	7 Nm at 40 min ⁻¹	10 Nm at 40 min ⁻¹	15 Nm at 30 min ⁻¹
Drive shafts	Semi hollow shaft, solid shaft, external square, customised shafts upon request						
Shaft materials	1.4305						
Housing material	E: Stainless steel 1.4301 A: Aluminium AlMgSi						A: Aluminium AlMgSi
Weight E / A ⁽⁵⁾	3.0 / 1.6 kg	3.5 / 2.0 kg	3.0 / 1.6 kg	3.5 / 2.0 kg	3.0 / 1.6 kg	3.5 / 2.0 kg	- / 2.5 kg
Degree of protection	IP 67, EN 60529:2014-09, shaft sealing ring made of Viton						
Shock resistance	150 m/s ² (approx. 15 g); as per DIN EN 60068-2-27:2010-02						
Vibration resistance	50 m/s ² (approx. 5 g), 10 to 50 Hz; as per DIN EN 60068-2-6:2008-10						
Ambient data							
Assured operating temperature range	0 °C to +60 °C						
Operating temperature range	-10 °C to +60 °C						
Storage temperature range	-20 °C to +85 °C						
Max. relative humidity of air	95%						
Condensation	Not permitted (condensation protection upon request)						

(1) external fuse required

(2) PD length of space

(3) If the supply voltage is present, an electronic counter measures the positioning range over the detection range of the measuring system.

(4) Use only screened cables.

(5) Dependent on the housing material (stainless steel / aluminium) and the type of connection

Technical data

Nominal torque (housing size)	01 (K)	02 (L)	03 (K)	05 (L)	07 (K)	10 (L)	15 (L)
UL data (design C)							
cULus recognised component, E196161	UL 61800-5-1 CSA C22.2 No. 274-13						
Input voltage (power circuits)	24 V to 30 V DC						
Input power (power circuits), continuous operation	45 VA	65 VA	45 VA	65 VA	45 VA	65 VA	
Input power (power circuits), ED = 1 minute, PD ⁽¹⁾ = 3 minutes	60 VA	80 VA	60 VA	80 VA	60 VA	80 VA	
Protection class	Type 1						
Assured operating temperature range	0 °C to +55 °C						
Operating temperature range	-10 °C to +55 °C						

⁽¹⁾ PD length of space

Connector M23

Type of connection **H1 / H2 / H3**

Technical data – coupling / connector (connector size M23)	
Rated voltage	Max. 30 V AC / DC
Current carrying capacity	According to DIN EN 60512
Contact type (coupling / connector)	Male / female
Housing material coupling / connector	Nickel-plated brass (others upon request)
Union nut material	Nickel-plated brass
Ambient temperature	-20 °C to +130 °C
Degree of protection ⁽¹⁾	IP 66 / IP 67
Mating cycles	> 500
Vibration resistance	≤ 200 m/s ²
Approval	cULus recognised component (no. E247738)

Connector M17

Type of connection **HS / S1 / S2 / S3**

Technical data – coupling / connector (connector size M17)	
Rated voltage	Max. 30 V AC / DC
Current carrying capacity	According to DIN EN 60512
Contact type (coupling / connector)	Male / female
Housing material coupling / connector	Brass, die-cast zinc and encapsulated in plastic
Ambient temperature	-20 °C to +130 °C
Degree of protection ⁽¹⁾	IP 66 / IP 67
Mating cycles	> 500
Approval	cULus recognised component (no. E247738)

Technical data, cables

Hybrid cable	Design 0 (standard)	Design 1 (separate fuse protection)	Design C (cULus recognised component)
Sheath material	PUR, black, glossy	PUR, black, matt	PUR, black, matt
Cable properties	Screened	Screened	Screened
Suitable for drag chains	Yes	Yes	Yes
Food grade	Yes	No	No
Halogen-free	No	Yes	Yes
Cable diameter (d)	9.5 mm	9.5 mm	9.5 mm
Bending radius	Permanently flexible: 10 × d Fixed routing: 5 × d	Permanently flexible: 15 × d Freely moving: 10 × d Fixed routing: 5 × d	Permanently flexible: 15 × d Freely moving: 10 × d Fixed routing: 5 × d
Peak operating voltage	Max. 350 V CAN bus Max. 30 V DC (logic / power)	Max. 300 V CAN bus Max. 30 V DC (logic / power)	Max. 300 V CAN bus Max. 30 V DC (logic / power)
Temperature range	-40 °C to +80 °C	-40 °C to +80 °C	-40 °C to +80 °C

⁽¹⁾ In the screwed-in state, according to DIN EN 60529 / DIN 40050

Device overview — types of connection

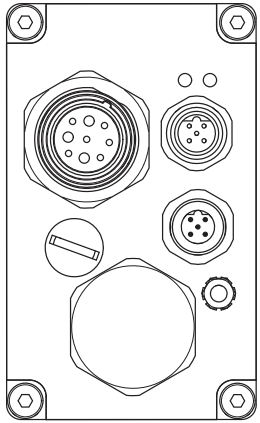
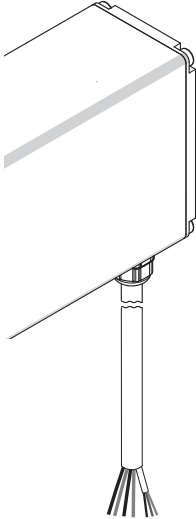
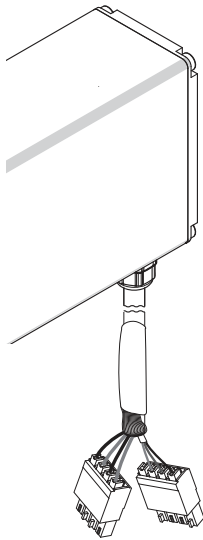
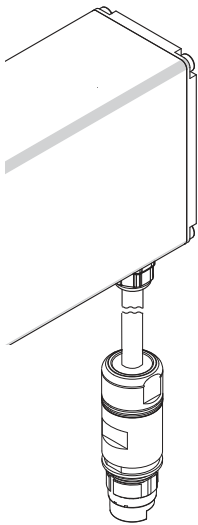
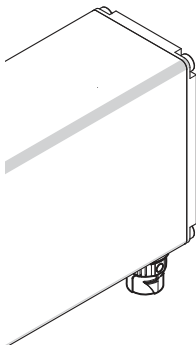
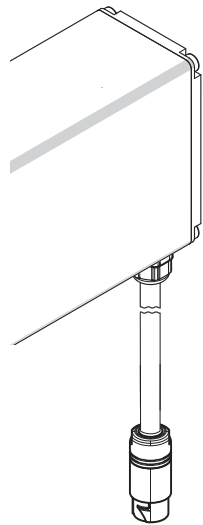
ST	xx: Cable length can be selected (1 m to 20 m)	Vx: Cable length can be selected (1 m to 20 m)
Plug outlet	Flying lead	Cable with spring-cage terminals for the SeGMO-Box connection
		
<p>Communication interfaces:</p> <ul style="list-style-type: none"> CO (CANopen) DP (PROFIBUS-DP) EC (EtherCAT) IP (EtherNet/IP) MB (Modbus/TCP) PL (POWERLINK) RT (PROFINET IO / RT) SC (SERCOS III) 	<p>Communication interface CO (CANopen)</p>	<p>Communication interface CO (CANopen)</p>
<p>H1: Cable length 30 cm H2: Cable length 50 cm H3: Cable length 100 cm</p>	HS	<p>S1: Cable length 30 cm S2: Cable length 50 cm S3: Cable length 100 cm</p>
Cable with M23 connector (coupling with pin contacts)	M17 panel-mounting socket (pin contacts)	Cable with M17 connector (coupling with pin contacts)
		
<p>Communication interface CO (CANopen)</p>	<p>Communication interface CO (CANopen)</p>	<p>Communication interface CO (CANopen)</p>

Type of connection ST

Rear side

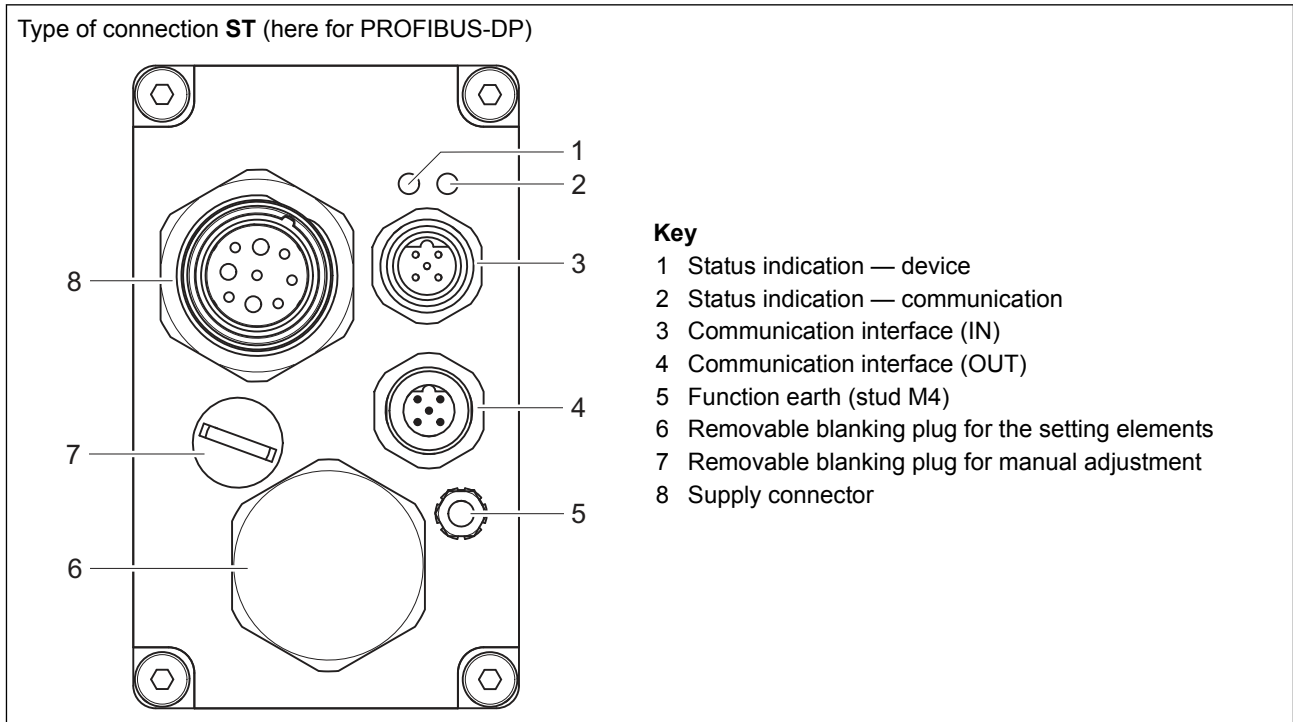

Setting elements, fieldbus variants (communication interface CO and DP)

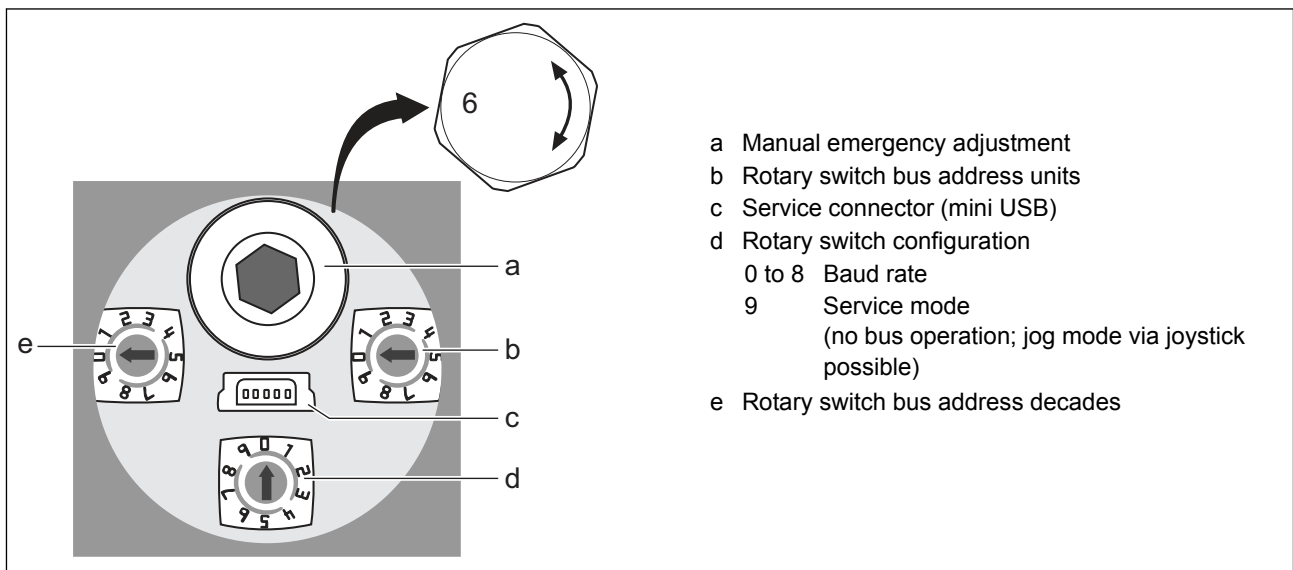

Manual adjustment, fieldbus variants (communication interface CO and DP)

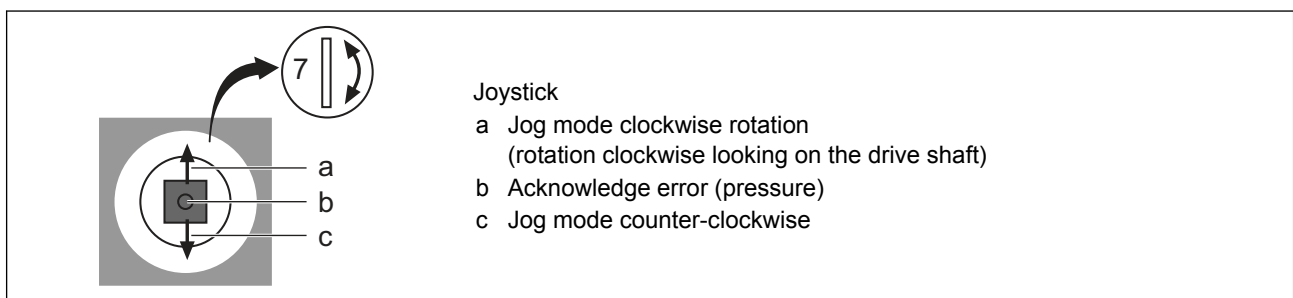

Type of connection ST

Setting elements for Industrial Ethernet variants (communication interfaces EC, MB, SC, PL, RT und IP)

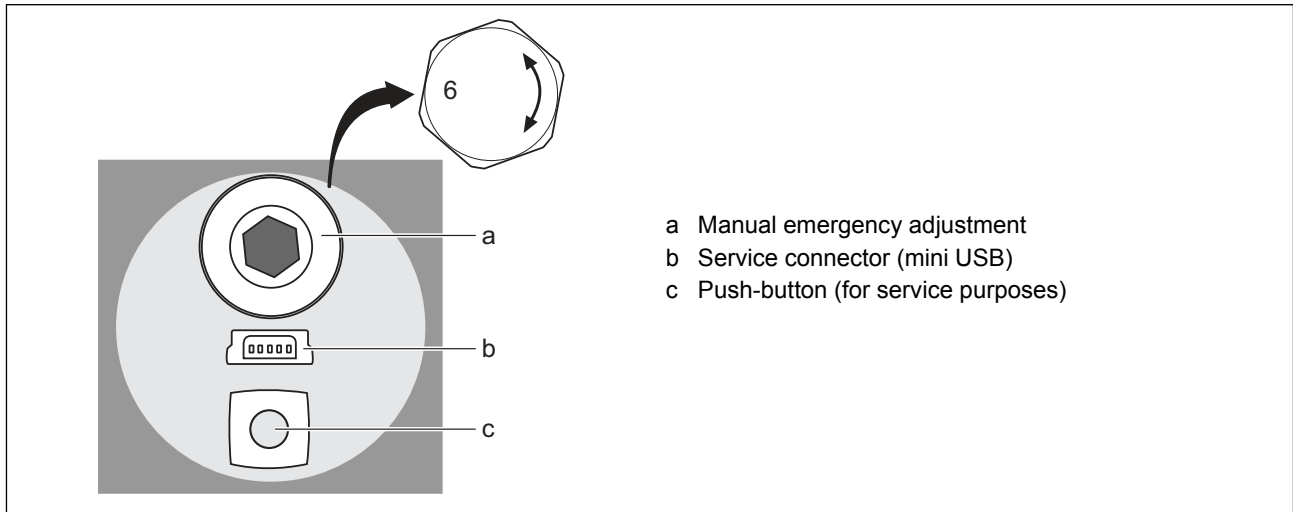

Pin layout – supply connector

Supply connector	Pin identifier	Signal identifier
M23 Pins	1	+ 24 V DC logic circuits
	2	GND logic circuits
	6	+ 24 V DC power circuits
	8	GND power circuits
GND wires connected internally.		

Pin layout – communication interfaces

CANopen	PROFIBUS-DP	Industrial Ethernet Sercos III; POWERLINK; PROFINET IO / RT; EtherCAT; EtherNet/IP; Modbus/TCP																																								
M12 A-coded IN OUT Male Female	M12 B-coded IN OUT Male Female	2 × M12 D-coded Switch sockets																																								
<table border="1"> <thead> <tr> <th>Pin</th> <th>IN / OUT</th> </tr> </thead> <tbody> <tr> <td>1</td> <td>Cable screen</td> </tr> <tr> <td>2</td> <td>n.c.</td> </tr> <tr> <td>3</td> <td>CAN GND</td> </tr> <tr> <td>4</td> <td>CAN high</td> </tr> <tr> <td>5</td> <td>CAN low</td> </tr> </tbody> </table>	Pin	IN / OUT	1	Cable screen	2	n.c.	3	CAN GND	4	CAN high	5	CAN low	<table border="1"> <thead> <tr> <th>Pin</th> <th>IN</th> <th>OUT</th> </tr> </thead> <tbody> <tr> <td>1</td> <td>n.c.</td> <td>5 V bus voltage</td> </tr> <tr> <td>2</td> <td>A-wire</td> <td>A-wire</td> </tr> <tr> <td>3</td> <td>n. c.</td> <td>GND Bus</td> </tr> <tr> <td>4</td> <td>B-wire</td> <td>B-wire</td> </tr> <tr> <td>5</td> <td>Cable screen</td> <td>Cable screen</td> </tr> </tbody> </table>	Pin	IN	OUT	1	n.c.	5 V bus voltage	2	A-wire	A-wire	3	n. c.	GND Bus	4	B-wire	B-wire	5	Cable screen	Cable screen	<table border="1"> <thead> <tr> <th>Pin</th> <th>IN / OUT</th> </tr> </thead> <tbody> <tr> <td>1</td> <td>Transmission Data+</td> </tr> <tr> <td>2</td> <td>Receive Data+</td> </tr> <tr> <td>3</td> <td>Transmission Data-</td> </tr> <tr> <td>4</td> <td>Receive Data-</td> </tr> </tbody> </table>	Pin	IN / OUT	1	Transmission Data+	2	Receive Data+	3	Transmission Data-	4	Receive Data-
Pin	IN / OUT																																									
1	Cable screen																																									
2	n.c.																																									
3	CAN GND																																									
4	CAN high																																									
5	CAN low																																									
Pin	IN	OUT																																								
1	n.c.	5 V bus voltage																																								
2	A-wire	A-wire																																								
3	n. c.	GND Bus																																								
4	B-wire	B-wire																																								
5	Cable screen	Cable screen																																								
Pin	IN / OUT																																									
1	Transmission Data+																																									
2	Receive Data+																																									
3	Transmission Data-																																									
4	Receive Data-																																									

Type of connection ST

Connection accessories for type of connection ST⁽¹⁾

Description	Item no.
Mating connector PROFIBUS-DP, M12, B-coded input (female)	FS3016
Mating connector PROFIBUS-DP, M12, B-coded output (male)	FS3017
Terminating resistor PROFIBUS-DP, M12, B-coded (male)	FS3041
Mating connector CANopen, M12, A-coded input (female)	FS3020
Mating connector CANopen, M12, A-coded output (male)	FS3021
Terminating resistor CANopen, M12, A-coded (male)	FS3040
Mating connector Industrial Ethernet input/output, M12, D-coded (male)	FS3039
PROFIBUS-DP, 1 connector, male, 10 m cable	FS3024
PROFIBUS-DP, 1 connector, female, 10 m cable	FS3025
PROFIBUS-DP, 1 connector, male, 2 m cable	FS3026
PROFIBUS-DP, 1 connector, female, 2 m cable	FS3027
PROFIBUS-DP, 2 connectors, female/male, 2 m cable	FS3028
Network cable Ethernet, M12 D-coded (male) on RJ45, 3 m cable	BK6921
Mating connector power supply M23 (female)	FS3038
Mating connector power supply M23 (female, angled)	FS3067
Connection cable power supply M23 (female) and flying lead	BZK23S1N__L ^(a)
^(a) for __ cable length, state in m (min. 3 m / max. 20 m)	

Power supply cable connection accessories (see Technical information BZK)

Connection cable BZK23S1NxxL / BZK23S1UxxL / BZK23S1CxxL
(xx = length in m)

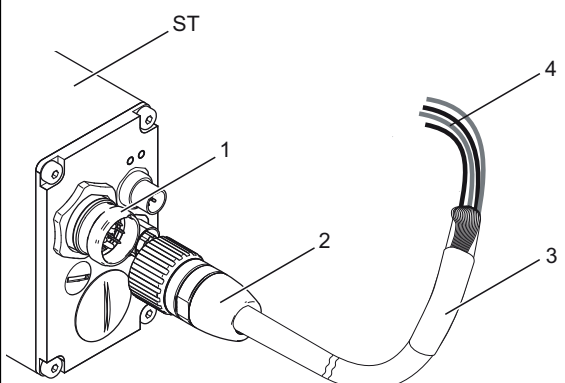

Power supply cable for the positioning drive with type of connection ST

ST Positioning drive with type of connection ST

1 Supply connector on the positioning drive

2 Connector 1/connector design **S1**

3 Design

N 16 AWG food grade

U 16 AWG halogen-free or

C 14 AWG cULus recognised

4 Connector 2: **L**
(flying lead)

Connection accessories: Mating connector power supply (M23 female)

Item no. FS3038

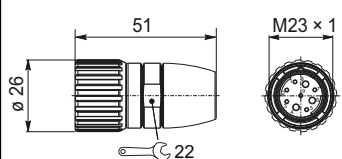

Item no. FS3067

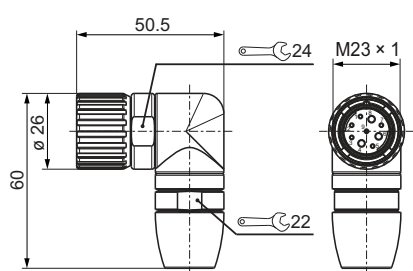

⁽¹⁾ Other accessories: fieldbus cable, couplings etc. upon request

Type of connection H1 / H2 / H3 / S1 / S2 / S3 / xx / Vx

Rear side

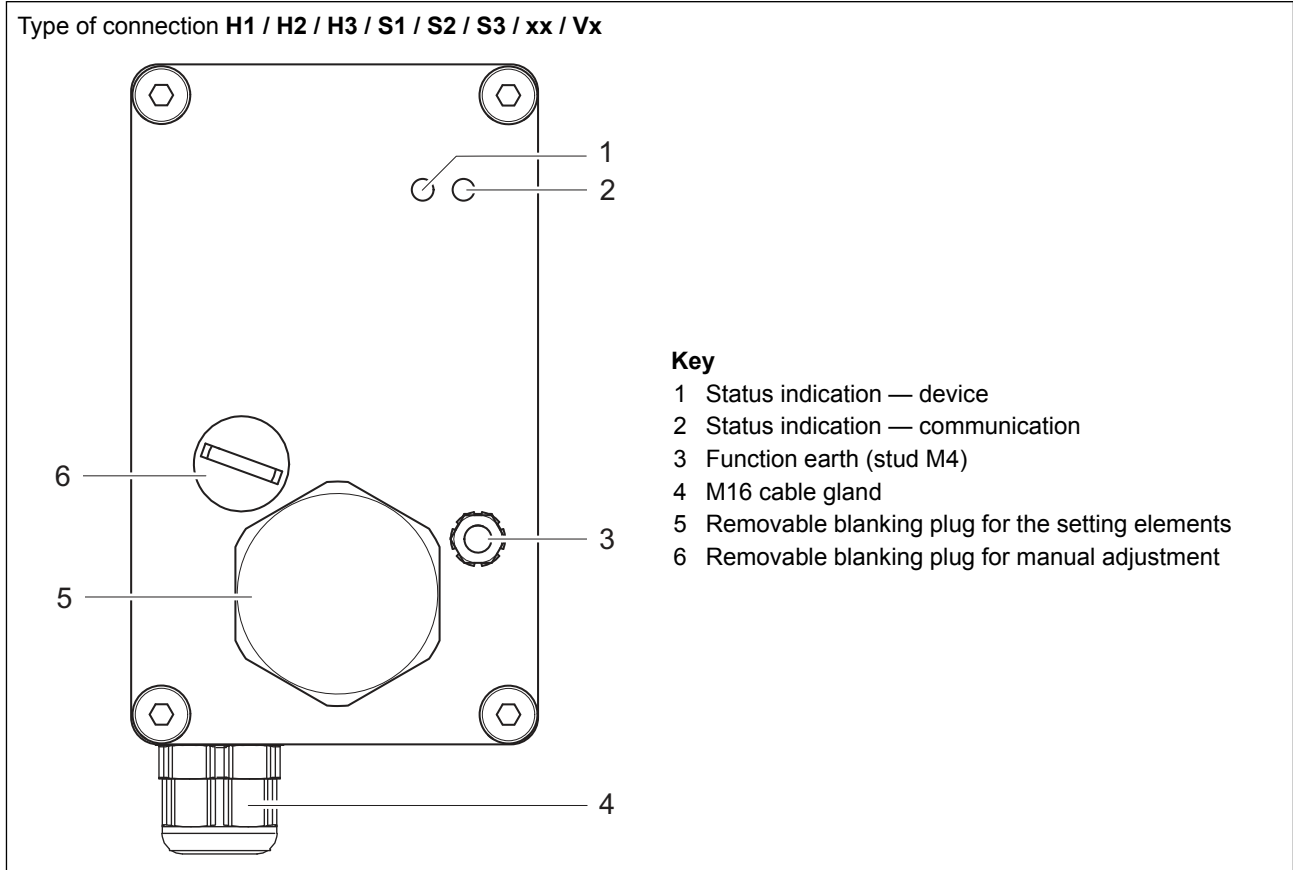

Setting elements CANopen (communication interface CO)

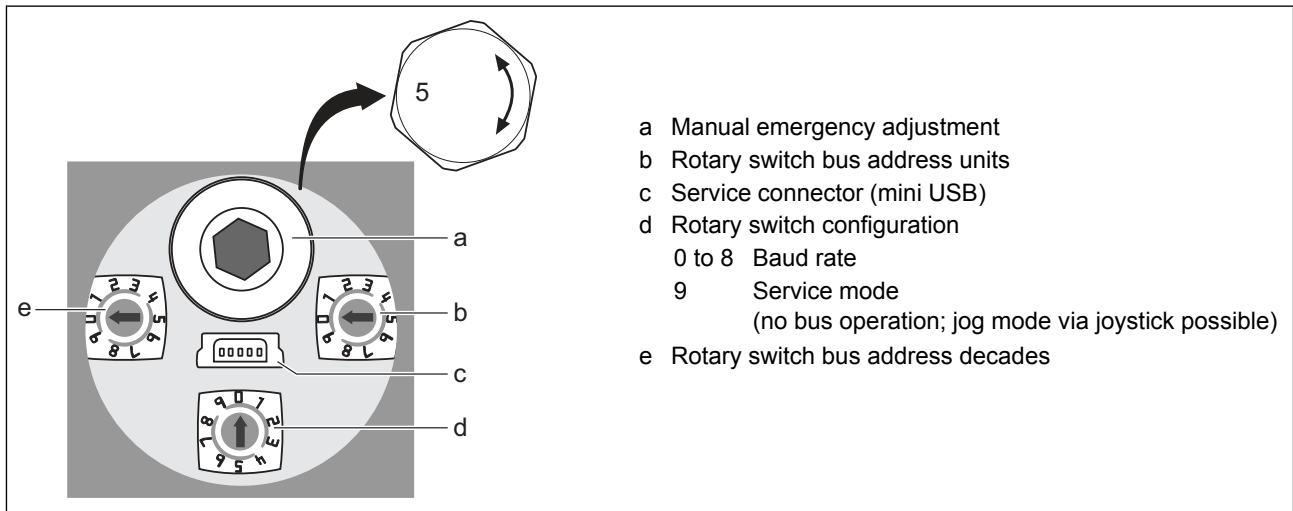

Manual adjustment CANopen (communication interface CO)

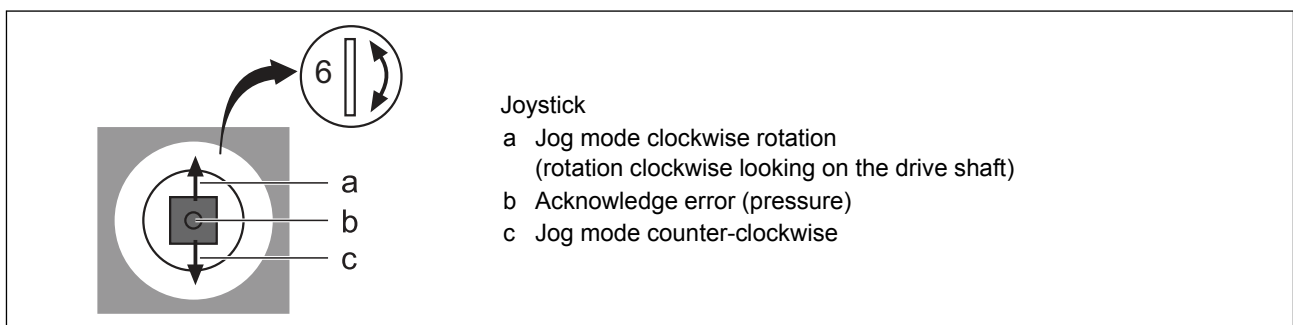

Type of connection H1 / H2 / H3 / S1 / S2 / S3 / xx / Vx

Terminal assignment xx / Vx

Type of connection xx : flying lead				Type of connection Vx : pre-assembled for the box connection		Signal identifier
Core colour/ core no.	cross-sec- tion Design 0	cross-sec- tion Design 1	cross-sec- tion Design C	4-pole spring-cage terminal (internal positioning drive communication) pin identifier	4-pole spring-cage terminal (position- ing drive power supply) pin identifier	
red/1	0.5 mm ²	0.5 mm ²	0.5 mm ²	–	3	+24 V logic cir- cuits
red/2	1.5 mm ²	1.5 mm ²	2.5 mm ²	–	1	+24 V power cir- cuits
black/2	1.5 mm ²	1.5 mm ²	2.5 mm ²	–	2	GND power cir- cuits
black/1	0.5 mm ²	0.5 mm ²	0.5 mm ²	–	4	GND logic circuits
black	0.14 mm ²	0.14 mm ²	0.14 mm ²	1	–	CAN GND
green	0.25 mm ²	0.25 mm ²	0.25 mm ²	3	–	CAN low
yellow	0.25 mm ²	0.25 mm ²	0.25 mm ²	2	–	CAN high

Type of connection H1 / H2 / H3 / S1 / S2 / S3 / xx / Vx

Pin layout H1 / H2 / H3

M23 connector		
Coupling with pin contacts	Pin identifier	Signal identifier
	A	+24 V logic circuits
	B	GND logic circuits
	C	GND power circuits
	D	+24 V power circuits
	E	Cable screen
	7	CAN high
	8	CAN GND
	9	CAN low
	S	CAN screen

Connection accessories H1 / H2 / H3 (see Technical information BZK)

H1: 30 cm
H2: 50 cm
H3: 100 cm

optional
BZK23S0NxxK
BZK23S0UxxK
BZK23S0CxxK

BZK23S0NxxK
BZK23S0UxxK
BZK23S0CxxK

BZK23S0NxxL
BZK23S0UxxL
BZK23S0CxxL

BZK23S0NxxV
BZK23S0UxxV

→ SeGMo-Box

BZK23S0CxxV

→ SeGMo-Box

xx = length in m

Type of connection H1 / H2 / H3 / S1 / S2 / S3 / xx / Vx

Pin layout S1 / S2 / S3

M17 connector		
Coupling with pin contacts	Pin identifier	Signal identifier
	A	+24 V logic circuits
	B	+24 V power circuits
	C	GND power circuits
	1	GND logic circuits
	2	CAN GND
	3	CAN low
	4	CAN high

Connection accessories S1 / S2 / S3 (see Technical information BZK)

S1: 30 cm
S2: 50 cm
S3: 100 cm

optional
BZK17S0NxxK
BZK17S0UxxK
BZK17S0CxxK

BZK17S0NxxK
BZK17S0UxxK
BZK17S0CxxK

BZK17S0NxxL
BZK17S0UxxL
BZK17S0CxxL

BZK17S0NxxV
BZK17S0UxxV

→ SeGMo-Box

BZK17S0CxxV

→ SeGMo-Box

xx = length in m

Type of connection HS

Rear side

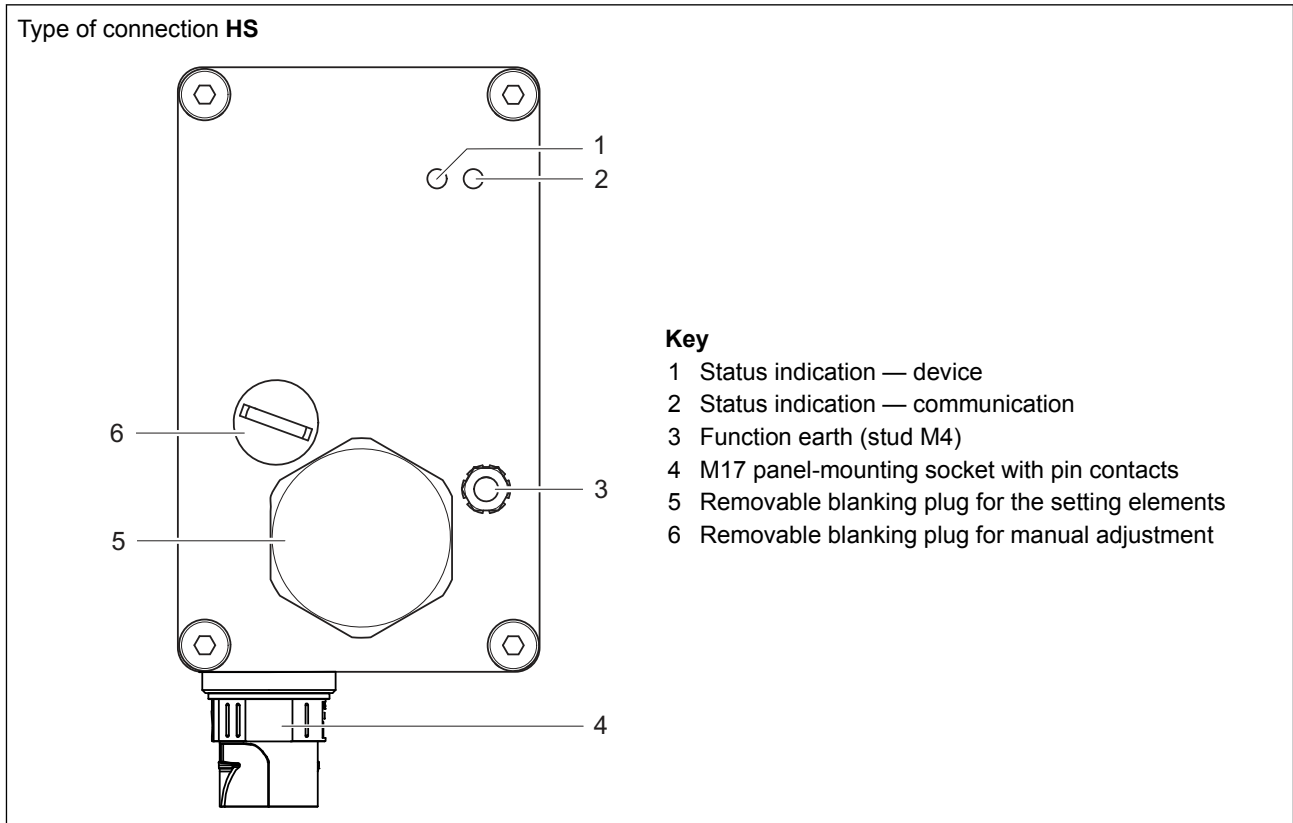

Setting elements CANopen (communication interface CO)

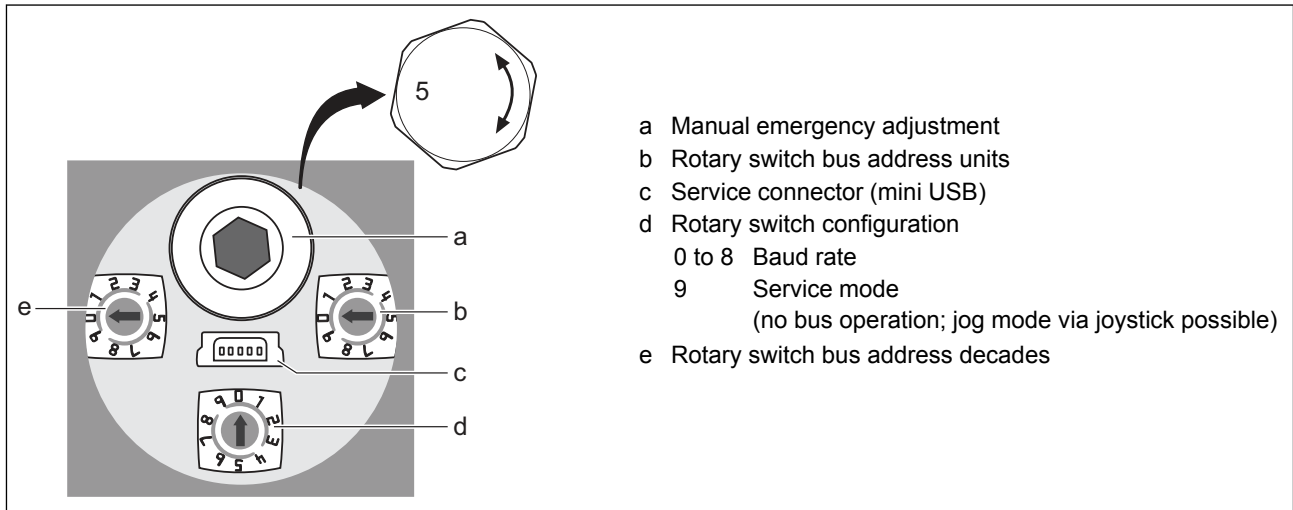

Manual adjustment CANopen (communication interface CO)

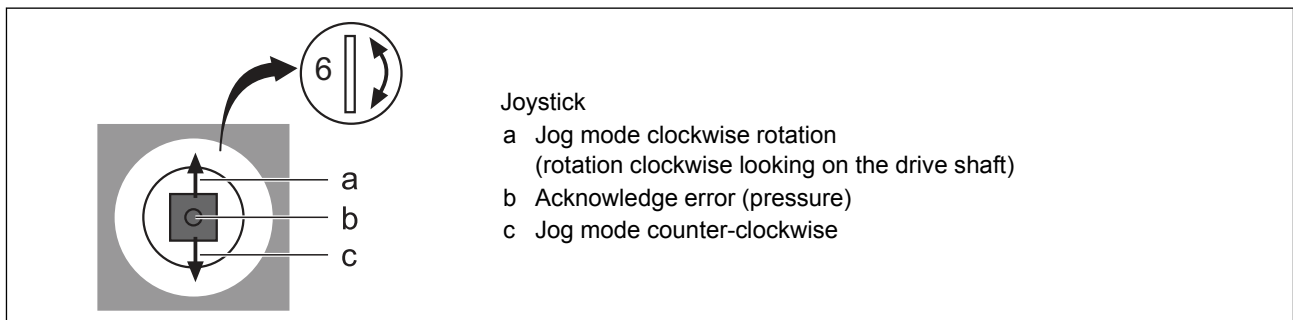

Type of connection HS

Pin layout HS

M17 connector		
Panel-mounting socket with pin contacts	Pin identifier	Signal identifier
	A	+24 V logic circuits
	B	+24 V power circuits
	C	GND power circuits
	1	GND logic circuits
	2	CAN GND
	3	CAN low
	4	CAN high

Connection accessories HS (see Technical information BZK)

optional

BZK17S0NxxK
BZK17S0UxxK
BZK17S0CxxK

BZK17S0NxxK
BZK17S0UxxK
BZK17S0CxxK

BZK17S0NxxL
BZK17S0UxxL
BZK17S0CxxL

BZK17S0NxxV
BZK17S0UxxV

BZK17S0CxxV

xx = length in m

Accessories

Mechanical accessories (not included in the scope of supply)

Identifier:	Item no.
Clamping ring for shaft: — A / B / N / P — C / D — E / F / H — O / R / Q — I	MZ13651 MZ13701 MZ13711 MZ13761 MZ1379
Accessories kit for GEL 6110 ≤ 10 Nm and GEL 6109 , consisting of: ▪ 1 pc. torque support including plain bearing, item no. BG5012 ▪ 2 pcs. screw M5×8, item no. VS2107 ▪ 1 pc. headless screw M5×20, item no. VS3412	ZB6100
Accessories kit for GEL 6110 ≥ 15 Nm , consisting of: ▪ 1 pc. torque support including plain bearing, item no. BG5017 ▪ 4 pcs. screw M5×8, item no. VS2107 ▪ 1 pc. headless screw M5×20, item no. VS3412	ZB6101
Accessories kit for exchanging a GEL 6110 10 Nm with a GEL 6110 ≥ 15 Nm , consisting of: ▪ 1 pc. torque support including plain bearing, item no. BG5060 ▪ 4 pcs. screw M5×8, item no. VS2107 ▪ 1 pc. headless screw M5×20, item no. VS3412	ZB6102
Accessories kit for GEL 6110 ≥ 15 Nm , consisting of: ▪ 1 pc. torque support including plain bearing, item no. BG5061 ▪ 4 pcs. screw M5×8, item no. VS2107 ▪ 1 pc. headless screw M5×20, item no. VS3412	ZB6103
Plain bearing accessories package (Contents: 5 pcs. plain bearing, item no. OG0001)	ZB61X01
Headless screws accessories package (Contents: 5 pcs. headless screw M5 × 20, item no. VS3412)	ZB61X02
Torque support screws accessories package (Contents: 10 pcs. screw M5 × 8, item no. VS2107)	ZB61X03

Dimensional drawings

All dimensions stated in mm (\approx approximate dimension); General tolerance DIN ISO 2768 medium

GEL 6110 (up to 15 Nm) with semi hollow shaft ⁽¹⁾

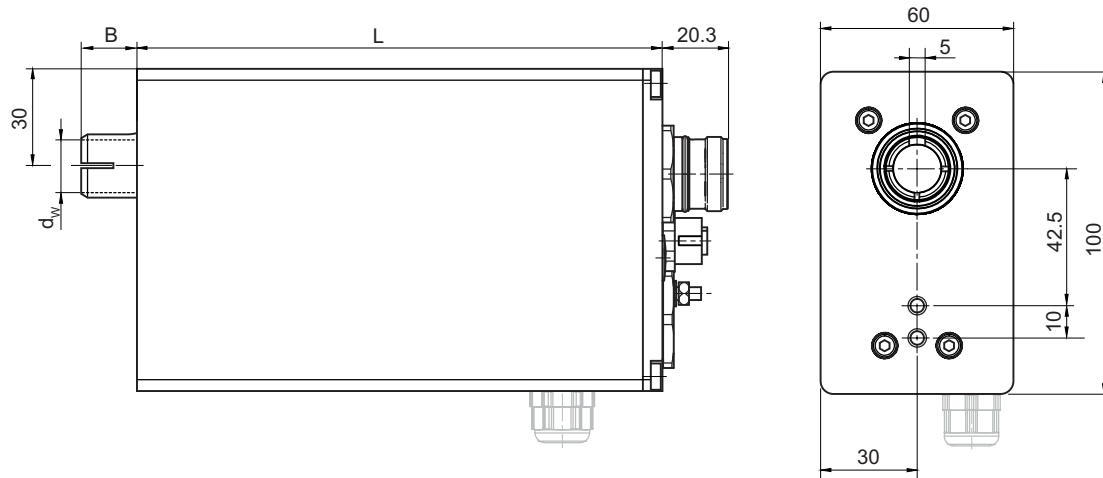

Dimension L depending on the housing size

Nominal torque	Housing size	Length L
01, 03, 07	K	126
02, 05, 10	L	164
15	L	166.5

Dimension B / $\varnothing d_w$ Depending on the shaft type

Type	I	H	F	E	D	C	B	A	P	N	Q	R	O	
$\varnothing d_w$	8 H7	9 H7	10 H7	11 H7	12 H7	13 H7	14 H7	15 H7	16 H7	17 H7	18 H7	19 H7	20 H7	
B							17.5					19.5		
B (≥ 15 Nm)							23.5					25.5		

Grey: Hybrid cable type of connection

H1 / H2 / H3 / S1 / S2 / S3 / Vx / xx

Accessories kit ZB6100

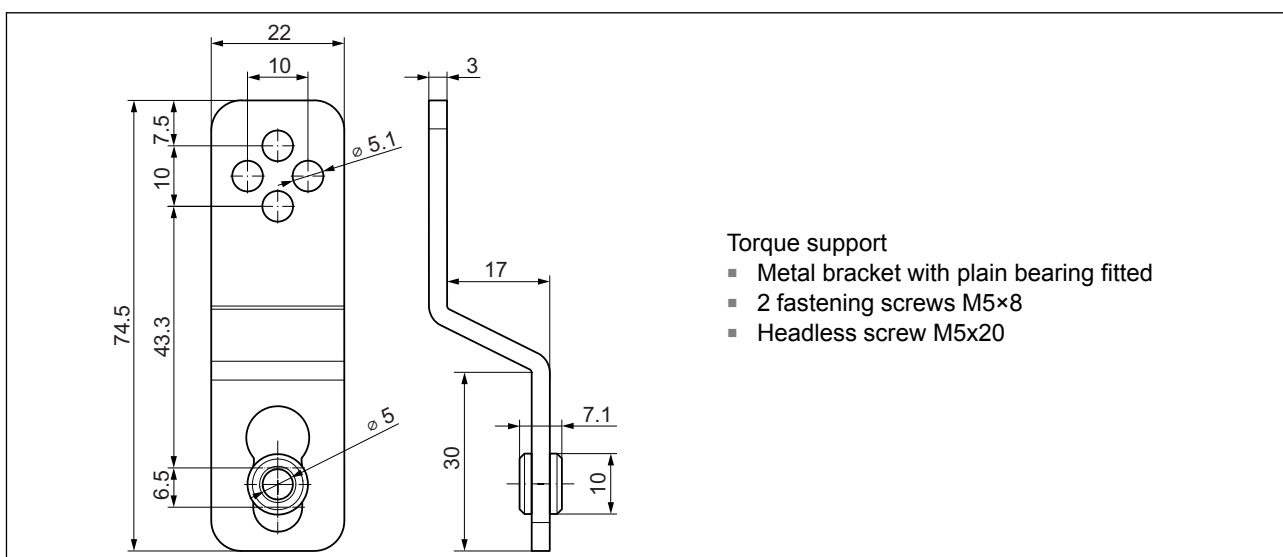

Torque support

- Metal bracket with plain bearing fitted
- 2 fastening screws M5x8
- Headless screw M5x20

⁽¹⁾ Device dimensions for shaft types G / K / L corresponding

Dimensional drawings

Accessories kit ZB6101

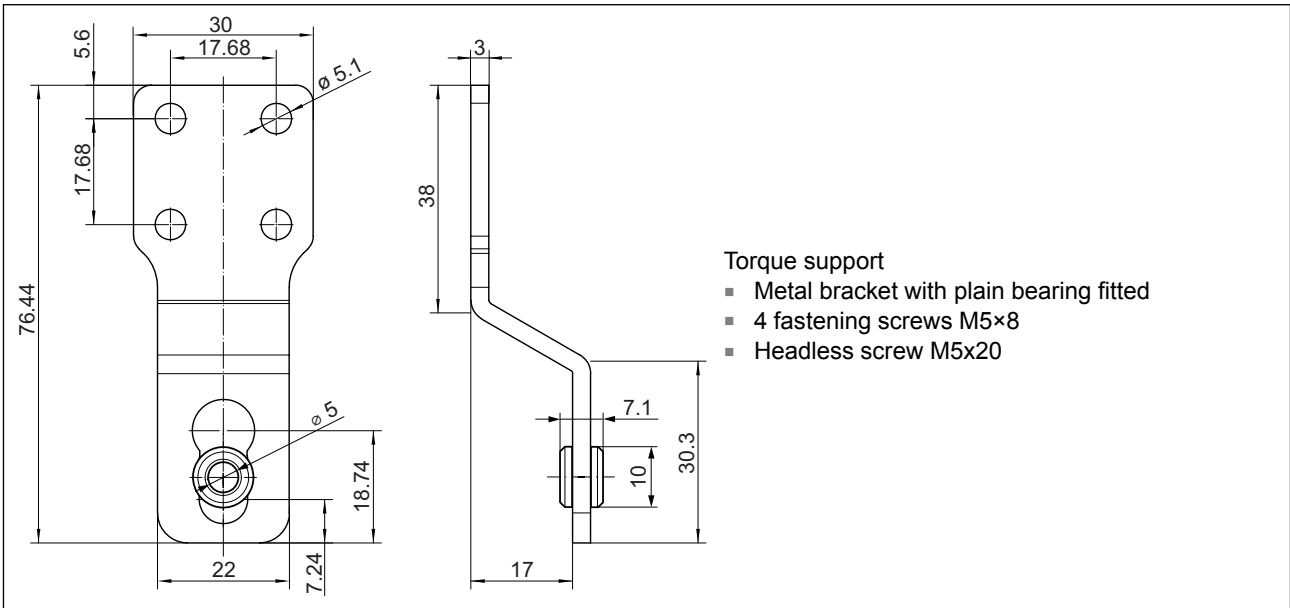

Accessories kit ZB6102

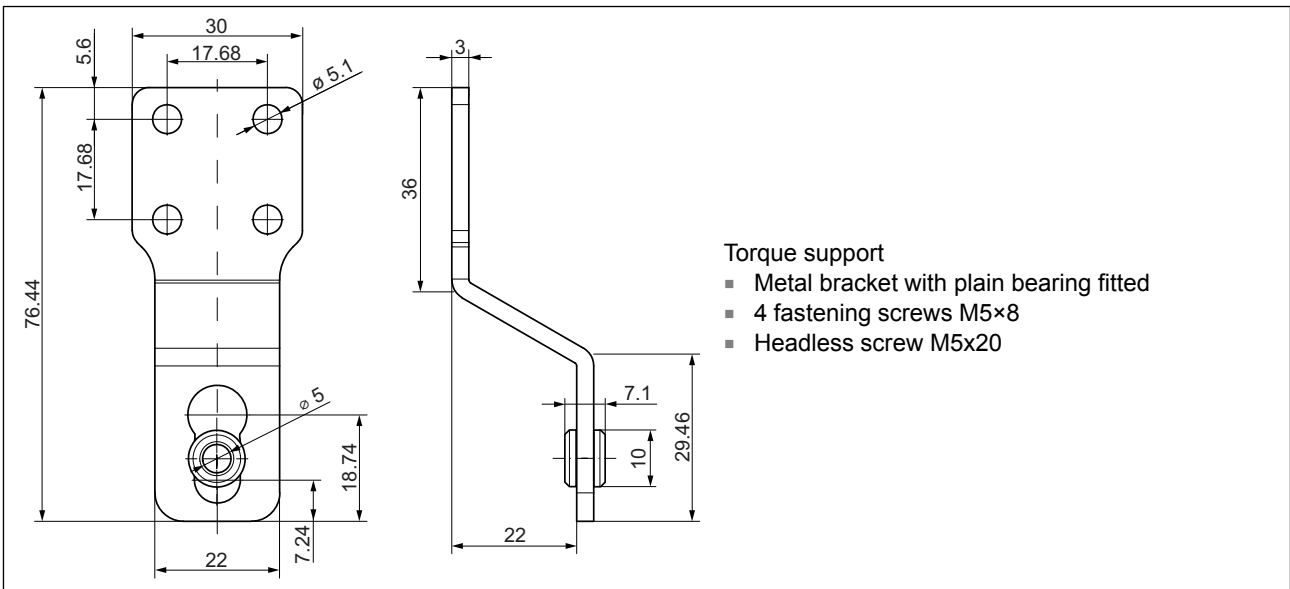

Dimensional drawings

Accessories kit ZB6103

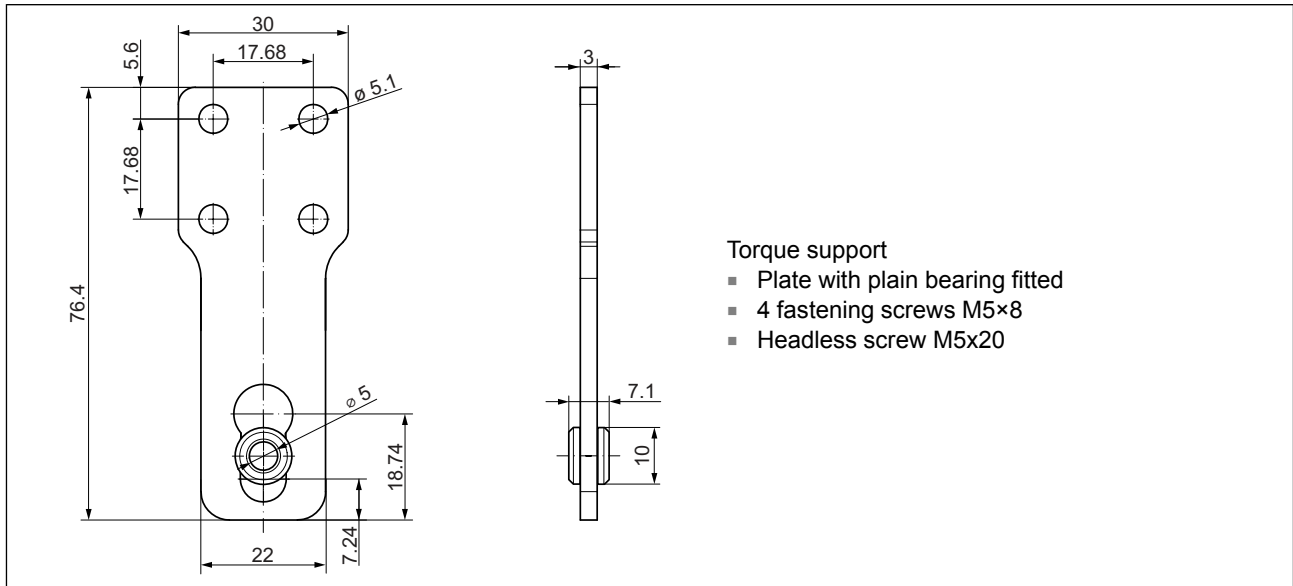

Clamping ring

Dimensions	MZ13711	MZ13701	MZ13651	MZ13761
	Shaft d_w H7 [mm] (type code)	9 / 10 / 11 (H / F / E)	12 / 13 (D / C)	14 / 15 / 16 / 17 (B / A / P / N)
	D [mm]	39.4	41.2	46.4
	b [mm]	13	13	15
	Screw DIN 912	M5	M5	M6

Clamping ring

Dimensions	MZ1379	
	Shaft d_w H7 [mm] (type code)	8 (I)
	D [mm]	28
	b [mm]	11
	Screw DIN 912	M4

Plain bearing OG0001

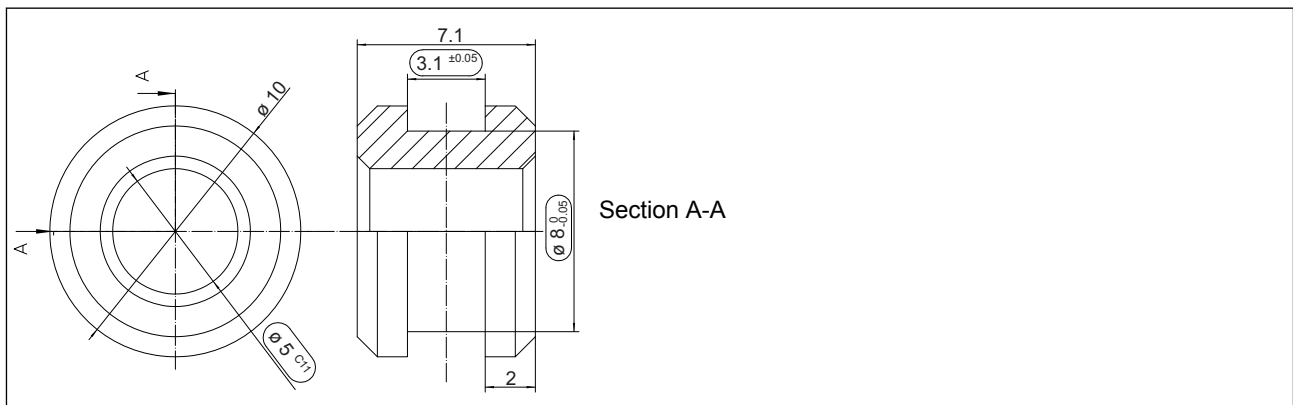

Other mounting material made of stainless steel 1.4301: centring pins, flange plates etc. upon request.

Type code

Type code GEL 6110

6110	Communication interface	
	CO	CANopen CiA 402
	DP	PROFIBUS-DP V0/V1
	EC	EtherCAT
	IP	EtherNet/IP
	MB	Modbus/TCP
	PL	POWERLINK
	RT	PROFINET IO / RT
	SC	Sercos III
	Nominal torque	
01	1.4 Nm at 230 min ⁻¹	
02	2 Nm at 230 min ⁻¹	
03	3.5 Nm at 100 min ⁻¹	
05	5 Nm at 100 min ⁻¹	
07	7 Nm at 40 min ⁻¹	
10	10 Nm at 40 min ⁻¹	
15	15 Nm at 30 min ⁻¹	
Shaft [d_w in mm]		
A	15 H7 semi hollow shaft	
B	14 H7 semi hollow shaft	
C	13 H7 semi hollow shaft	
D	12 H7 semi hollow shaft	
E	11 H7 semi hollow shaft	
F	10 H7 semi hollow shaft	
G	10 H7 hollow shaft, flush (only form-fit)	
H	9 H7 semi hollow shaft	
I	8 H7 semi hollow shaft	
K	10 h7 solid shaft	
L	10 external square	
N	17 H7 semi hollow shaft	
O	20 H7 semi hollow shaft	
P	16 H7 semi hollow shaft	
Q	18 H7 semi hollow shaft	
R	19 H7 semi hollow shaft	
Housing material		
A	Aluminium AlMgSi	
E	Stainless steel 1.4301	
Housing size		
K	Short	
L	Long	
Type of connection		
ST	Connector (standard: M12 fieldbus, M23 supply)	
HS	M17 panel-mounting socket with pin contacts	
S1	30 cm hybrid cable and M17 coupling with pin contacts	
S2	50 cm hybrid cable and M17 coupling with pin contacts	
S3	100 cm hybrid cable and M17 coupling with pin contacts	
H1	30 cm hybrid cable and M23 coupling with pin contacts	
H2	50 cm hybrid cable and M23 coupling with pin contacts	
H3	100 cm hybrid cable and M23 coupling with pin contacts	
Vx	Hybrid cable pre-assembled with connection terminals for SeGMo-Box, Cable length V1 = 1 m; V2 = 3 m; V3 = 5 m; V4 = 8 m; V5 = 10 m; V6 = 13 m; V7 = 15 m; V8 = 18 m; V9 = 20 m	
xx	xx m hybrid cable with flying lead, length in m (xx = 01...20; standard: 3 m)	
Design		
0	Standard	
1	Separate fuse protection	
C	cULus recognised component	
Option		
A	No additional option (standard)	
B	Holding brake	



Lenord, Bauer & Co. GmbH
Dohlenstraße 32
46145 Oberhausen, Germany
Phone: +49 208 9963-0
Fax: +49 208 676292
Internet: www.lenord.com
E-Mail: info@lenord.de

Right to technical changes and errors reserved.